

Vibration Diagnostic Guide





The SKF brand now stands for more than ever before, and means more to you as a valued customer.

While SKF maintains its leadership as the hallmark of quality bearings throughout the world, new dimensions in technical advances, product support and services have evolved SKF into a truly solutions-oriented supplier, creating greater value for customers.

These solutions encompass ways to bring greater productivity to customers, not only with breakthrough application-specific products, but also through leading-edge design simulation tools and consultancy services, plant asset efficiency maintenance programmes, and the industry's most advanced supply management techniques.

The SKF brand still stands for the very best in rolling bearings, but it now stands for much more.

SKF – the knowledge engineering company

Contents

Part 1	3
Overview	3
How to use this guide	3
Detection vs. analysis	3
Vibration (amplitude vs. frequency)	3
“Overall” vibration	4
Time waveform analysis	7
FFT spectrum analysis	7
Envelope detection	7
SEE technology	8
Phase measurement	9
High frequency detection (HFD)	9
Other sensor resonant technologies	9
Part 2	14
Spectrum analysis techniques	14
Misalignment	15
Imbalance	17
Looseness	19
Bent shaft	20
Bearing cocked on a shaft	20
Bearing defects	21
Multi-parameter monitoring	25
Appendix A	
Understanding phase	26
Glossary	28

Part 1

Overview

This guide is designed to introduce machinery maintenance workers to condition monitoring analysis methods used for detecting and analyzing machine component failures.

This document was created by field experienced SKF application engineers using measurements obtained with SKF Condition Monitoring equipment. This guide is a “living document” and will continuously grow as application and experience information becomes available.

It is important to note that this guide is not intended to make the reader an analysis expert. It merely informs the reader about “typical” methods of analysis and how machinery problems “typically” show themselves when using these methods of analysis. It is intended to lay the foundation for understanding machinery analysis concepts and to show the reader what is needed to perform an actual analysis on specific machinery.

Rule 1: Know what you know and do not pretend to know what you do not know!

Often, a situation arises where the answer is not obvious or not contained within the analysis data. At this point “I don’t know” is the best answer. A wrong diagnosis can cost greatly and can rapidly diminish the credibility of the machinery maintenance worker. Analysis of the problem by a vibration specialist is required.

How to use this guide

This guide is divided into two sections.

- The first section introduces concepts and methods used to detect and analyze machinery problems.
- The second section examples “typical” ways in which various machinery problems show themselves and how these problems are “typically” analyzed.

A glossary is provided at the end of this document. Reference this glossary for any unfamiliar terms.

Detection vs. analysis

Cause and effect

There is a big difference between detecting a machinery problem and analyzing the cause of a machinery problem. Swapping out a bearing that is showing wear by vibrating heavily may or may not solve your problem. Usually, some other machinery problem is causing the bearing to wear prematurely. To solve the bearing problem, you must solve the cause of the bearing problem (e.g., misalignment, looseness, imbalance). If not, you are not running a condition monitoring program, you are running a bearing exchange program.

It is essential that machinery problems be detected early enough to plan repair actions and to minimize machine downtime.

Once detected, a cause and effect approach must be used to take further steps toward analyzing what caused the detected problem. Only then will you keep the problem from becoming a repeat problem.

Vibration (amplitude vs. frequency)

Vibration is the behavior of a machine’s mechanical components as they react to internal or external forces.

Since most rotating machinery problems show themselves as excessive vibration, we use vibration signals as an indication of a machine’s mechanical condition. Also, each mechanical problem or defect generates vibration in its own unique way. We therefore analyze the “type” of vibration to identify its cause and take appropriate repair action.

When analyzing vibration, we look at two components of the vibration signal; its amplitude and its frequency.

- **Frequency** is the number of times an event occurs in a given time period (the event being one vibration cycle). The frequency at which the vibration occurs indicates the type of fault. That is, certain types of faults “typically” occur at certain frequencies. By establishing the frequency at which the vibration occurs, we get a clearer picture of what could be causing it.
- **Amplitude** is the size of the vibration signal. The amplitude of the vibration signal determines the severity of the fault. The higher the amplitude, the higher the vibration, the bigger the problem. Amplitude depends on the type of machine and is always relative to the vibration level of a “good”, “new” machine.

When measuring vibration, we use certain standard measurement methods:

- Overall vibration
- Phase
- Acceleration enveloping
- SEE technology (acoustic emissions)
- High frequency detection (HFD)
- Other sensor resonant technologies

“Overall” vibration

Overall vibration is the total vibration energy measured within a frequency range. Measuring the “overall” vibration of a machine or component, a rotor in relation to a machine, or the structure of a machine, and comparing the overall measurement to its normal value (norm) indicates the current health of the machine. A higher than normal overall vibration reading indicates that “something” is causing the machine or component to vibrate more.

Vibration is considered the best operating parameter to judge low frequency dynamic conditions such as imbalance, misalignment, mechanical looseness, structural resonance, soft foundation, shaft bow, excessive bearing wear or lost rotor vanes.

Frequency range

The frequency range for which the overall vibration reading is performed is determined by the monitoring equipment. Some data collectors have their own predefined frequency range for performing overall vibration measurements. Other data collectors allow the user to select the overall measurement’s frequency range. Unfortunately, there is an ongoing debate on which frequency range best measures to measure overall vibration (even though the International Organization for Standardization (ISO) has set a standard definition). For this reason, when comparing overall values, it is important that both overall values be obtained from the same frequency range.

Scale factors

When comparing overall values, the scale factors that determine how the measurement is measured must be consistent. Scale factors used in overall vibration measurements are Peak, Peak-to-Peak, Average and RMS. These scale factors have direct relationships to each other when working with sinusoidal waveforms. The figure below shows the relationship of Average vs. RMS vs. Peak vs. Peak-to-Peak for a sinusoidal waveform.

- Peak = 1,0
- RMS = 0,707 × Peak
- Average = 0,637 × Peak
- Peak-to-Peak = 2 × Peak

Scale factors on a sinusoidal vibration waveform.

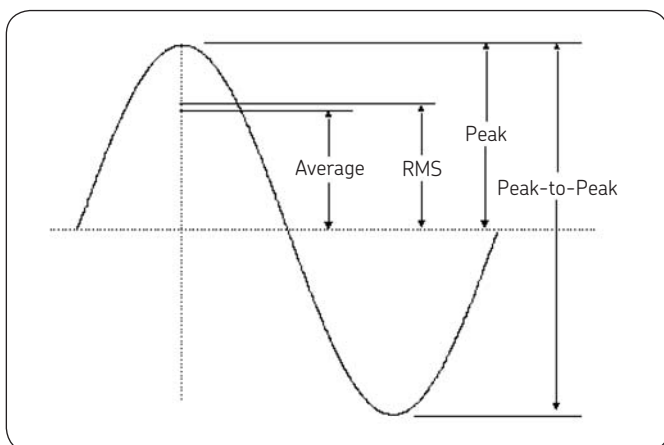

The Peak value represents the distance to the top of the waveform measured from a zero reference. For discussion purposes, we will assign a Peak value of 1,0.

The Peak-to-Peak value is the amplitude measured from the top most part of the waveform to the bottom most part of the waveform.

The Average value is the average amplitude value for the waveform. The average of a pure sine waveform is zero (it is as much positive as it is negative). However, most waveforms are not pure sinusoidal waveforms. Also, waveforms that are not centered around zero volts produce non-zero average values.

Visualizing how the RMS value is derived is a bit more difficult. Generally speaking, the RMS value is derived from a mathematical conversion that relates DC energy to AC energy. Technically, on a time waveform, it is the root mean squared (RMS). On a FFT spectrum, it is the square root of the sum of a set of squared instantaneous values. If you measured a pure sine wave, the RMS value is 0,707 times the peak value.

Note: Peak and Peak-to-Peak values can be either true or scaled. Scaled values are calculated from the RMS value.

Do not be concerned about the math – the condition monitoring instrument calculates the value. What is important to remember is when comparing overall vibration signals, it is imperative that both signals be measured on the same frequency range and with the same scale factors.

Note: As discussed in future sections, for comparison purposes, measurement types and locations must also be identical.

Measurement sensor position

Select the best measurement point on the machine. Avoid painted surfaces, unloaded bearing zones, housing splits and structural gaps.

When measuring vibration with a handheld sensor, it is imperative that you perform consistent readings, paying close attention to the sensor’s position on the machinery, the sensor’s angle to the machinery and the contact pressure with which the sensor is held on the machinery.

Position – When possible, vibration should be measured in three directions:

- The axial direction (A)
- The horizontal direction (H)
- The vertical direction (V)

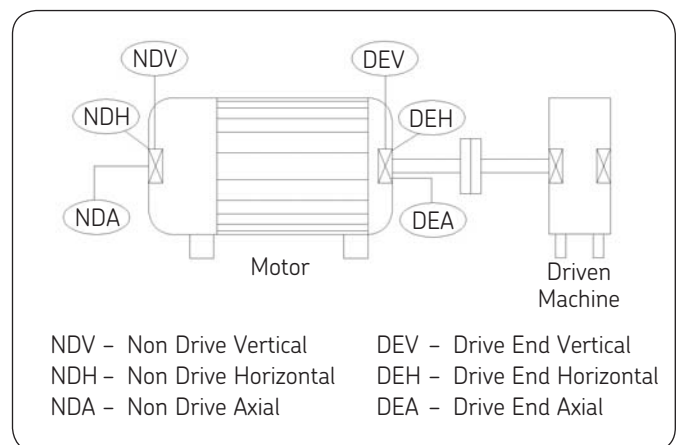

- **Horizontal** measurements typically show the most vibration due to the machine being more flexible in the horizontal plane. Also, imbalance is one of the most common machinery problems and imbalance produces a radial vibration, that is, part vertical and part horizontal. Because the machine is usually more flexible in the horizontal plane, excessive horizontal vibration is a good indicator of imbalance.
- **Vertical** measurements typically show less vibration than horizontal because of stiffness due to mounting and gravity.
- Under ideal conditions, axial measurements should show very little vibration, as most forces are generated perpendicular to the shaft. However, misalignment and bent shaft problems do create vibration in the axial plane.

Note: These descriptions are given as guidelines for “typical” machinery only. Equipment that is vertically mounted, overhung or in some way not typical may show different responses.

Since we generally know how various machinery problems create vibration in each plane, vibration readings taken in these three positions can provide insight as to what may be causing any excessive vibration. Note that measurements should be taken as close to the bearing as possible. If possible, avoid taking readings on the case, as the case could be vibrating due to resonance or looseness.

Note: Enveloping and SEE measurements should be taken as close to the bearing load zone as possible.

If possible, choose a flat surface to press the sensor tip against. Measurements should be taken at the same precise location for comparison (moving the probe only a few inches can produce drastically different vibration readings). To ensure measurements are taken at the exact same spot, mark the measurement point with permanent ink or machine a shallow conical hole with a drill point.

Magnetic mounts are even better for consistency and permanently mounted sensors are the best for consistency.

- **Angle** – Always perpendicular to the surface (90°, ±10°).
- **Pressure** – Even, consistent hand pressure must be used (firm, but not so firm as to dampen the vibration signal).

Optimum measurement conditions

Perform measurements with the machine operating under normal conditions, for example, when the rotor, housing and main bearings have reached their normal steady operating temperatures and with the machine running under its normal rated condition (for example, at rated voltage, flow, pressure and load). On machines with varying speeds or loads, perform measurements at all extreme rating conditions in addition to selected conditions within these limits.

Trending overall readings

Probably the most efficient and reliable method of evaluating vibration severity is to compare the most recent overall reading against previous readings for the same measurement, allowing you to see how the measurement’s vibration values are changing, “trending” over time. This trend comparison between present and past readings is easier to analyze when the values are plotted in a “trend plot”.

A trend plot is a line graph that displays current and past overall values plotted over time. Past values should include a baseline (known good) reading. The baseline value may be acquired after an overhaul or when other indicators show that the machine is running well. Subsequent measurements are compared to the baseline to determine machinery changes.

Comparing a machine to itself over time is the much preferred method for detection of machinery problems, as each machine is unique in its operation. For example, some components have a certain amount of vibration that would be considered a problem for most machines, but is normal for them. The current reading by itself might lead an analyst to believe that a problem exists, whereas the trend plot and baseline reading would clearly show that a certain amount of vibration is normal for this machine.

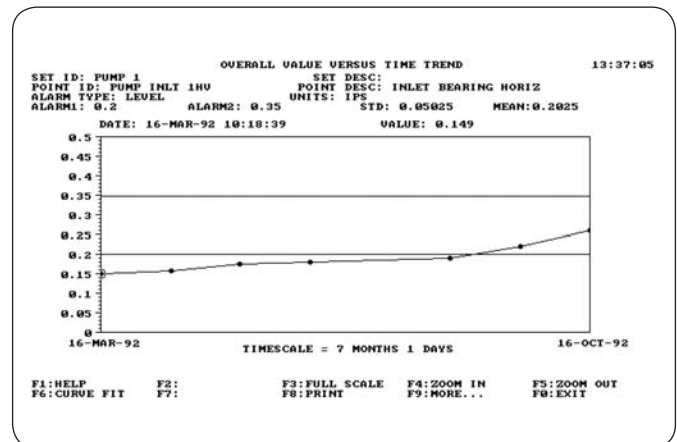

ISO Standards are good for a start (until you develop a machine history). However, ISO charts define “good” or “not good” conditions for various wide-ranged machinery classifications.

Every machine is:

- Manufactured differently
- Installed differently (foundation)
- Operated under different conditions (load, speed, materials, environment)
- Maintained differently

It is unrealistic to judge a machine’s condition by comparing its current measurement value against a wide classification ISO Standard or other general rule or levels. By comparing current values to historical values, you are able to easily see how a specific machine’s condition is changing over time. You are comparing apples to apples.

Overall vibration measurements methods

Measuring vibration is the measurement of periodic motion. Vibration is exemplified using a spring-mass setup.

When the mass is set in motion, it oscillates on the spring. Viewing the oscillation as position over time produces a sine wave. The starting point (when the mass is at rest) is the zero point. One complete cycle of the mass displays a positive and a negative displacement of the mass in relation to its reference (zero). **Displacement** is the change in distance or position of an object relative to a reference. The magnitude of the displacement is measured as **amplitude**.

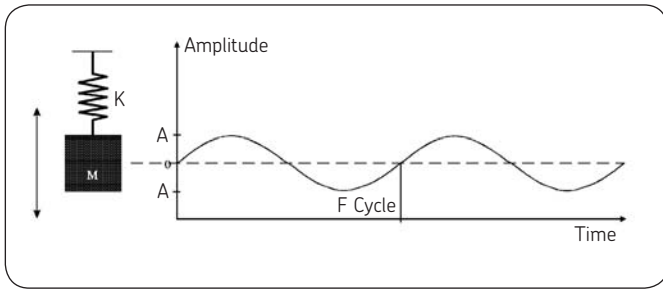

There are two measurable derivatives of displacement: velocity and acceleration.

- **Velocity** is the change in displacement as a function of time; it is speed at which the distance is traveled, for example, 0.2 in./sec.
- **Acceleration** is the rate of change of velocity. For example, if it takes one second for the velocity to increase from 0 to 1 in./sec, then the acceleration is 1 in./sec².

Thus, vibration has three measurable characteristics: displacement, velocity and acceleration. Although these three characteristics are related mathematically, they are three different characteristics, not three names for the same quantity.

It is necessary to select a vibration measurement and sensor type that measures the vibration most likely to reveal the expected failure characteristics.

Displacement

Measured in mils or micrometers, displacement is the change in distance or position of an object relative to a reference. Displacement is typically measured with a sensor commonly known as a displacement probe or eddy probe. A displacement probe is a non-contact device that measures the relative distance between two surfaces. Displacement probes most often monitor shaft vibration and are commonly used on machines with fluid film bearings.

Displacement probes measure only the motion of the shaft or rotor relative to the casing of the machine. If the machine and rotor are moving together, displacement is measured as zero, while in fact the machine could be vibrating heavily.

Displacement probes are also used to measure a shaft's phase. The shaft's phase is the angular distance between a known mark on the shaft and the vibration signal. This relationship is used for balancing and shaft orbital analysis (reference the *Phase* section).

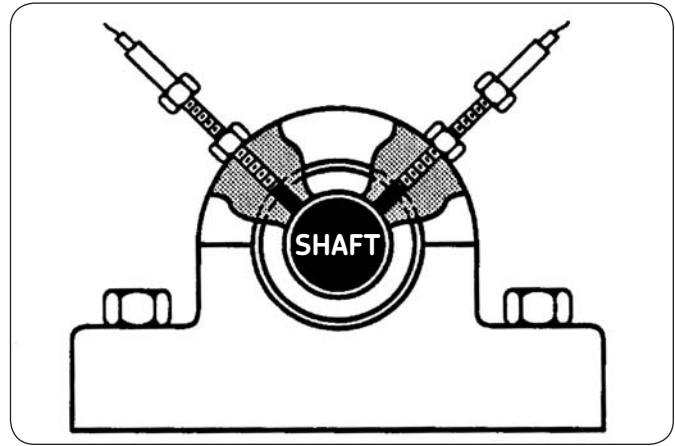

Velocity

Measured in in./sec or mm/sec, velocity measures the vibration signal's rate of change in displacement. It is the most common machine vibration measurement. Historically the velocity sensor was one of the first electrical sensors used for machine condition monitoring. This is because for an equal amount of dynamic motion being generated, velocity remains constant regardless of frequency. However, at very low frequencies (under 10 Hz), velocity sensors lose their effectiveness. Likewise at higher frequencies (above 2 kHz).

The original velocity transducer employed a coil vibrating in a magnetic field to produce a voltage proportional to the machine's surface velocity. Today, with the arrival of low cost and versatile accelerometers, most velocity values are obtained by integrating an acceleration reading into the velocity domain.

Acceleration

Acceleration is the rate of change in velocity. Vibration in terms of acceleration is measured with accelerometers. An accelerometer usually contains one or more piezoelectric crystal elements and a mass.

When the piezoelectric crystal is stressed, it produces an electrical output proportional to acceleration. The crystal is stressed by the mass when the mass is vibrated by the component to which they are attached.

Accelerometers are rugged devices that operate in a very wide frequency range from almost zero to well above 400 kHz. This ability to examine a wide frequency range is the accelerometer's major strength. However, since velocity is the most common measurement for monitoring vibration, acceleration measurements are usually integrated (either in the accelerometer itself or by the data collector) to get velocity. Acceleration units are G's, in./sec² or m/sec².

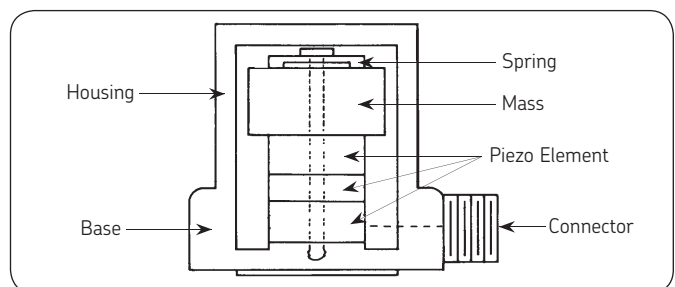

By mounting accelerometers at strategic points on bearings, we can measure the acceleration and derive the velocity. These measurements are recorded, analyzed and displayed as tables and plots by condition monitoring equipment. A plot of amplitude versus time is called a time waveform.

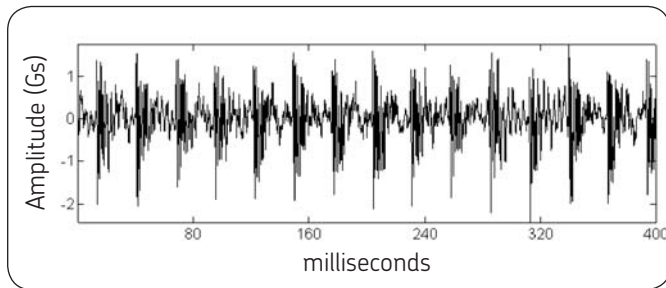

Time waveform analysis

The above time waveform plot illustrates how the signal from an accelerometer or velocity probe appears when graphed as amplitude over time. This type of vibration plot is also called a time domain plot or graph.

Time waveforms display a short time sample of the raw vibration. Though typically not as useful as other analysis formats, time waveform analysis can provide clues to machine condition that are not always evident in the frequency spectrum and, when available, should be used as part of your analysis program.

FFT spectrum analysis

A method of viewing the vibration signal in a way that is more useful for analysis is to apply a Fast Fourier Transformation (FFT). In non-mathematical terms, this means that the signal is broken down into specific amplitudes at various component frequencies.

For example, we measure the signal's amplitude at 10 Hz, then again at 20 Hz, etc., until we have a list of values for each frequency contained in the signal. These values or amplitudes are then plotted over the frequency scale. The number of component frequencies the waveform is divided into is referred to as the number of lines of resolution. The resulting plot is called an FFT spectrum.

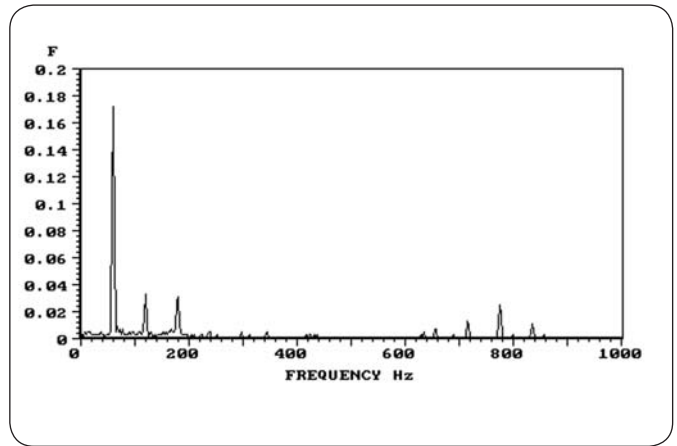

An FFT spectrum is an incredibly useful tool. If a machinery problem exists, FFT spectra provide information to help determine the location of the problem, the cause of the problem and, with trending, how long until the problem becomes critical. Because we know that certain machinery problems occur at certain frequencies, we analyze the FFT spectrum by looking for amplitude changes in certain frequency ranges.

Alternate signal processing methods

Along with time waveforms and FFT spectra, vibration signals are run through other processing methods to best analyze specific types of equipment and conditions. Running vibration signals through multiple processing methods also provides more ways to analyze the signal and more ways to measure deviations from the "norm". Following are a examples of alternate processing methods.

Envelope detection

Repetitive bearing and gear mesh activity create vibration signals of much lower amplitude and higher frequencies than rotational and structural vibration signals.

The object of enveloping is to filter out the low frequency rotational vibration signals and to enhance the repetitive components of a bearing's defect signals occurring in the bearing defect frequency range. Envelope detection is most common in rolling element bearing and gear mesh analysis where a low amplitude, repetitive vibration signal may be hidden by the machine's rotational and structural vibration noise.

For example, if a rolling element bearing has a defect on its outer race, each roller over-rolls the defect as it goes by and causes a small, repetitive vibration signal at the bearing's defects frequencies. However, this vibration signal is of such low energy that, with overall vibration monitoring, it is lost in the machine's other rotational and structural vibration noise.

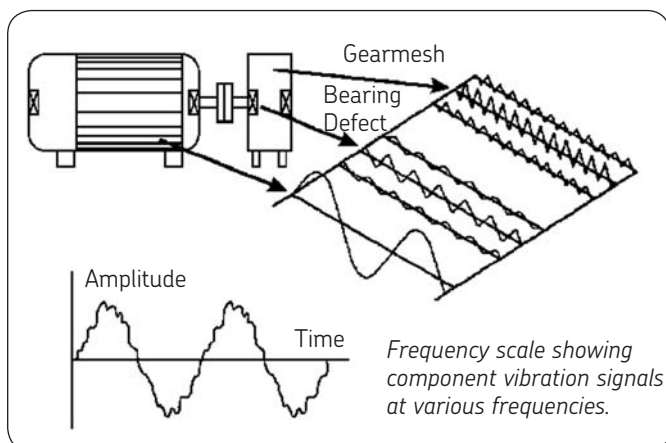

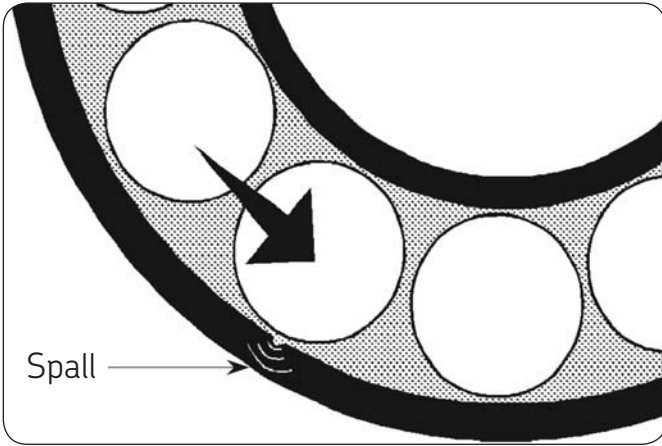

Circumstances that can cause acoustic emissions include:

- Bearing defects
- Contaminated lubrication
- Lack of lubrication
- Dynamic overloading
- Micro-sliding/fretting
- Bearing friction
- Cavitation/Flow
- Electrically generated signals
- Metal cutting
- Compressor rotor contact
- Electrical arcing
- Cracking or tin cry
- Electrical noise
- Materials striking materials

Envelope detection filters out low frequency rotational signals and enhances the bearing's repetitive impact type signals to focus on repetitive events in the bearing defect frequency range (for example, repetitive bearing and gear tooth vibration signals).

In recent times, this measurement method has proven to be a successful indicator of a major class of machine problems. Faults in roller element bearings, defective teeth in gear boxes, paper mill felt discontinuities and electric motor/stator problems are all applications for acceleration enveloping.

SEE technology

SEE (Spectral Emitted Energy) technology provides very early bearing and gear mesh fault detection by measuring acoustic emissions generated by metal as it fails or generated by other specific conditions.

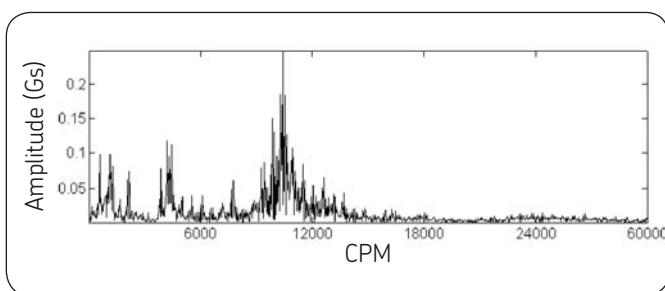

A spalled bearing's acceleration vibration spectrum.

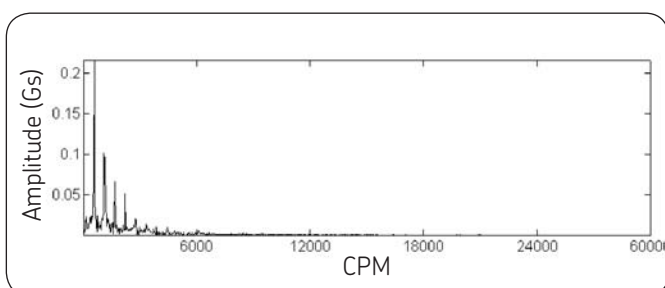

The same bearing's enveloped acceleration spectrum.

SEE technology uses a special acoustic emissions sensor that "listens" for ultrasonic acoustic emissions that occur when bearing elements degrade (these acoustic emissions occur in the 150 to 500 kHz range). This type of signal is not considered vibration as much as it is considered high frequency sound, however, vibration is the commonly used industrial term.

Since SEE technology measures the ultrasonic noise (acoustic emissions) created when metal degrades, it is the best tool for detecting bearing problems in their earliest stages, when the defect is subsurface or microscopic and not causing any measurable vibration signal. For that matter, SEE measurements are also very effective for measuring any machine condition that produces acoustic emissions such as corrosion and friction due to fretting, cavitation, sliding or friction events, etc.

If SEE values gradually rise above normal, there is usually no need to immediately replace the bearing. SEE detection provides enough pre-warning for the maintenance person to make operational or lubrication corrections and potentially save the bearing, or effectively extend its life.

If SEE values rise, monitor the bearing more closely (shorten measurement intervals and perform multi-parameter monitoring). Trend the bearing's condition with SEE, enveloping, temperature and vibration measurements to best analyze the problem and predict the best time for corrective action. A good understanding of the machine and a logical approach to problem solving is needed to help direct repair action.

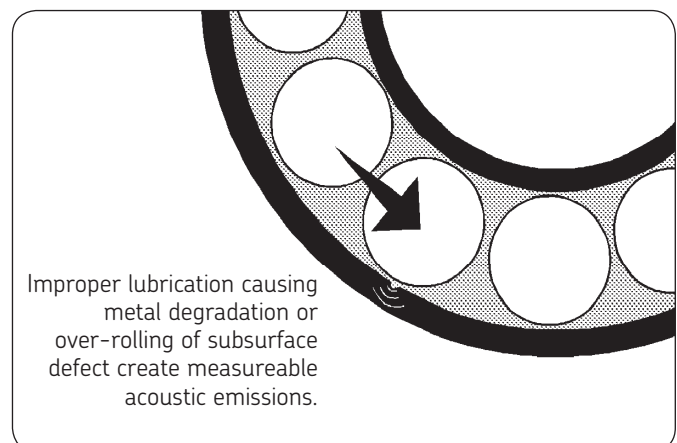

Phase measurement

Phase is a measurement, not a processing method. Phase measures the angular difference between a known mark on a rotating shaft and the shaft's vibration signal. This relationship provides valuable information on vibration amplitude levels, shaft orbit and shaft position and is very useful for balancing and analysis purposes. See *Appendix A* for a more detailed description of measuring phase.

High frequency detection (HFD)

HFD provides early warning of bearing problems. The high frequency detection (HFD) processing method displays a numerical overall value for high frequency vibration generated by small flaws occurring within a high frequency band pass (5 to 60 kHz). The detecting sensor's resonant frequency is within the band pass and used to amplify the low level signal generated by the impact of small flaws. Because of its high frequency range, the HFD measurement is made with an accelerometer and displays its value in G's. The HFD measurement may be performed as either a peak or RMS overall value.

Other sensor resonant technologies

Some competitors use sensor resonant technologies that are similar to HFD. Sensor resonant technologies use the sensor's resonant frequency to amplify events in the bearing defect range. These technologies enhance the repetitive components of a bearing's defect signals and report its condition. The reading is provided by an overall number representing how many impacts (enhanced logarithmically) the system picks up.

One competitor's technology is very similar to HFD and gives the same indications. However, measurement results between SKF's HFD technology and the competitor's technology cannot be compared due to different sensor sensitivities.

ISO 2372 Vibration Diagnostic Table (Horizontal Shift)

	Excessive	Excessive	Excessive	Excessive	
	Horizontal	Vertical	Axial	Structural	
	Vibration Indicates:	Vibration Indicates:	Vibration Indicates:	Vibration Indicates:	
Imbalance	YES	NO	NO	NO	Horizontal > Axial
Misalignment	NO	YES	YES	NO	Axial > Horizontal
Looseness	YES	YES	NO	YES	Vertical ≥ Horizontal
Electrical Faults Measures as Vibration					To detect an electrical problem: Turn off machine power and monitor vibration. If the vibration immediately drops, the problem is electrical.

Note: On an overhung machine, imbalance and misalignment may display similar characteristics. Use phase measurements to differentiate between the two.

Note: YES = ISO 2372 Unsatisfactory – Unacceptable Levels.

NO = ISO 2372 Good – Satisfactory Levels.

ISO 2372 Vibration Diagnostic Table (Overhung – Horizontal Shaft)

	Excessive Horizontal	Excessive Vertical	Excessive Axial	Excessive Structural	
	Vibration Indicates:	Vibration Indicates:	Vibration Indicates:	Vibration Indicates:	Notes
Imbalance	YES	NO	YES	NO	Horizontal and Axial > Vertical
Misalignment	YES	NO	YES	NO	Horizontal and Axial > Vertical
Looseness	YES	YES	NO	YES	Vertical ≥ Horizontal
Electrical Faults Measured as Vibration					To detect an electrical problem: Turn off machine power and monitor vibration. If the vibration immediately drops, the problem is electrical.

Note: On an overhung machine, imbalance and misalignment may display similar characteristics. Use phase measurements to differentiate between the two.

Note: YES = ISO 2372
Unsatisfactory – Unacceptable Levels.

NO = ISO 2372
Good – Satisfactory Levels.

ISO 2372 Vibration Diagnostic Table (Vertical Shaft)

	Excessive	Excessive	Excessive	Excessive	
	Horizontal	Vertical	Axial	Structural	
	Vibration Indicates:	Vibration Indicates:	Vibration Indicates:	Vibration Indicates:	Notes
Imbalance	YES	NO	NO	NO	Radial > Axial
Misalignment	YES	NO	YES	NO	Axial > Radial
Looseness	YES	NO	NO	YES	
Electrical Faults Measured as Vibration					To detect an electrical problem: Turn off machine power and monitor vibration. If the vibration immediately drops, the problem is electrical.

Note: Radial 1 and Radial 2 positions differ by 90 degrees.

Note: YES = ISO 2372 Unsatisfactory – Unacceptable Levels.

NO = ISO 2372 Good – Satisfactory Levels.

Spectrum Analysis Table

	Primary Plane	Detection Units	Dominant Frequencies	Phase Relationship	Comments
Imbalance					
• NOTE: Phase references are accurate within ± 30 degrees.					
Mass	Radial	Acceleration/ Velocity/ Displacement	1X	90 degree phase shift as sensor is moved from horizontal to vertical position. No radial phase shift across the machine or coupling.	
Overhung Mass	Axial and Radial	Acceleration/ Velocity/ Displacement	1X	Axial reading will be in phase.	Account for change in sensor orientation when making axial measurements.
Bent Shaft	Axial and Radial	Acceleration/ Velocity/ Displacement	1X	180 degree phase shift in the axial direction across the machine with no phase shift in the radial direction.	
Misalignment					
Angular	Axial	Acceleration/ Velocity/ Displacement	1X, 2X	A phase shift of 180 degrees in the axial direction will exist across the coupling.	With severe misalignment, the spectrum may contain multiple harmonics from 3X to 10X. If vibration amplitude in the horizontal plane is increased 2 or 3 times, then misalignment is again indicated. (Account for change in sensor orientation when making axial measurements.)
Parallel	Radial	Acceleration/ Velocity/ Displacement	1X, 2X	A phase shift of 180 degrees in the radial direction will exist across the coupling. Sensor will show 0° or 180 degrees phase shift as it is moved from horizontal to vertical position on the same bearing.	
Combination of Angular and Parallel	Axial and Radial	Acceleration/ Velocity/ Displacement	1X, 2X	A phase shift of 180 degrees in the radial and axial direction will exist across the coupling.	
Mechanical Looseness					
Structural	Radial	Acceleration/ Velocity/ Displacement	1X	Phase shifts of 180 degrees will exist between the machine's feet, baseplate, and/or foundation if the machine is rocking.	Usually caused when the machine's foundation degrades to such an extent that it is no longer stiff, causing the machine to "rock".
Soft Foot	Radial	Acceleration/ Velocity/ Displacement	1X, 2X, ...	Phase will shift when the machine foot is tightened.	Result of the machine footing coming loose from the foundation
Wear/ Fitting	Axial and Radial	Acceleration/ Velocity/ Displacement	1X, 2X, ... 10X	Phase reading will be unstable from one reading to the next.	Vibration amplitudes may vary significantly as the sensor is placed at different locations around the bearing. (Account for change in sensor orientation when making axial measurements).

Spectrum Analysis Table

	Primary Plane	Detection Units	Dominant Frequencies	Phase Relationship	Comments
Local Bearing Defects			<ul style="list-style-type: none"> NOTE: Phase references are accurate within ± 30 degrees. 		
Race Defect	Radial	Acceleration/ Enveloping/ SEE	4X ... 15X	No correlation.	With Acceleration measurements, bearing defect frequencies appear as a wide "bump" in the spectrum. Bearing defect frequencies are non-integer multiples of running speed (i.e., 4.32 X Running Speed).
Gear Defect					
Gear Mesh	Radial	Acceleration/ Enveloping/ SEE	20X ... 200X	No correlation.	The exact frequency relates to the number of teeth each gear has times the shaft rotation speed (running speed).
Electrically Induced					
AC Motors	Radial	Acceleration/ Velocity/ Displacement	Line Frequency (100 or 120 Hz)	No correlation.	Defect frequencies can be seen at exactly twice the line frequency.
DC Motors	Radial	Acceleration/ Velocity/ Displacement	SCR Frequency	No correlation.	DC motor problems due to broken field windings, bad SCR's or loose connections are reflected as higher amplitudes at the SCR frequencies (6xFL).

Part 2

Spectrum analysis techniques

How to use this section

Use the charts in the beginning of this section to get a quick picture of what may be causing excessive vibration. Then turn to the suspected problem's section to further understand and confirm your diagnosis.

Note: A spectrum is a spectrum is a spectrum. When measuring displacement, velocity or acceleration vibration, all data collectors should produce very similar spectra.

Spectrum analysis overview

As mentioned earlier, an FFT spectrum is an incredibly useful analysis tool. If a machinery problem exists, FFT spectra provide information to help determine the location of the problem, the cause of the problem and, with trending, how long until the problem becomes critical.

FFT spectra allow us to analyze vibration amplitudes at various component frequencies on the FFT spectrum. In this way, we can identify and track vibration occurring at specific frequencies. Since we know that specific machinery problems generate vibration at specific frequencies, we can use this information to diagnose what is causing the excessive vibration.

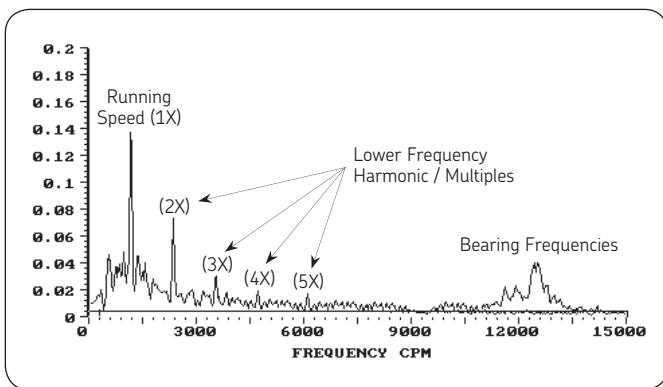

Step 1 – collect useful information

Certain information is needed before attempting to diagnose an FFT spectrum.

Identify all components of the machine that could cause vibration

Before a spectrum can be analyzed, the components that cause vibration within the machine must be known. In other words, what are the possibilities?

- If the machine is connected to a fan or pump, know the number of fan blades or impellers.
- If bearings are present, know their bearing defect frequencies.
- If the machine is connected to gears, know the number of teeth for each gear.
- If the machine is driven with belts, know the belt lengths.
- Is the machine operating in the same vicinity as another machine? If so, know the running speed of the adjacent machine. Vibration from one machine can travel through the foundation or structure and affect vibration levels on an adjacent machine.
- Is the machine mounted horizontally or vertically?
- Is the machine overhung or connected to anything that is overhung?

Identify the machine's running speed

Knowing the machine's running speed is critical when analyzing an FFT spectrum. There are several ways of determining running speed.

- Read the speed from instrumentation at the machine or from instrumentation in the control room monitoring the machine.
- Look for peaks in the spectrum at 1 800 or 3 600 r/min if the machine is a induction electric motor (1 500 and 3 000 r/min for 50 Hz countries). Electric motors usually run at these speeds.
- An FFT's running speed peak is "typically" the first significant peak reading the spectrum from left to right. Look for this peak and check for peaks at two times, three times, four times, etc., the suspected running speed frequency (2x, 3x, 4x). Harmonics usually cause vibrations at multiples of the running speed frequency (although they might be very small).

Identify what type of measurement produced the FFT spectrum

- Was it a displacement, velocity, acceleration, enveloping, SEE, etc., measurement that produced the spectrum?
- Where was the probe positioned: horizontal, vertical, axial, in the load zone?

If possible, obtain any historical machinery data

- Are previously recorded values, FFTs or overall trend plots available?
- Was a base-line recorded?

Step 2 – analyze

Once the previous information is known, you can proceed to analyze the spectrum. Analysis usually follows a process of elimination. Eliminate what is not on the spectrum and what is left is the problem(s).

Once running speed is determined, identify the spectrum's frequency ranges

- Identify any harmonics of running speed (1x, 2x, 3x, etc.).
- Identify bearing fault frequencies.
- Identify fan blade frequencies, if applicable.
- Identify number of gear teeth, if applicable.
- Identify pump impeller frequencies, if applicable.
- Identify adjacent machinery vibration, if applicable.
- If monitoring an electric motor, identify peaks at line frequencies. Try to find out if they are electrical or mechanical.

Verify suspected fault frequencies

The spectra may produce peaks at identified fault frequencies. These peaks may or may not represent the indicated fault. Look for harmonics to determine if the identified frequencies were generated from the indicated fault.

- If a peak appears at the fundamental fault frequency and another peak appears at two times the fundamental fault frequency, it is a very strong indication that the fault is real.
- If no peak appears at the fundamental fault frequency, but peaks are present at two, three and maybe four times the fundamental fault frequency, then this also represents a strong indication that the indicated fault is valid.

Determine the severity of the fault

- One way to determine the fault's severity is to compare its amplitude with past readings taken under consistent conditions.
- Another way is to compare the amplitude to other readings obtained by similar machines running under the same conditions. A higher than normal reading indicates a problem.

Misalignment

Overview

Most experts agree that over half of all machinery problems are caused by misalignment.

Misalignment is created when shafts, couplings and bearings are not properly aligned along their centerlines. The two types of misalignment are angular and parallel, or a combination of both.

Angular misalignment

Angular misalignment occurs when two shafts are joined at a coupling in such a way as to induce a bending force on the shaft.

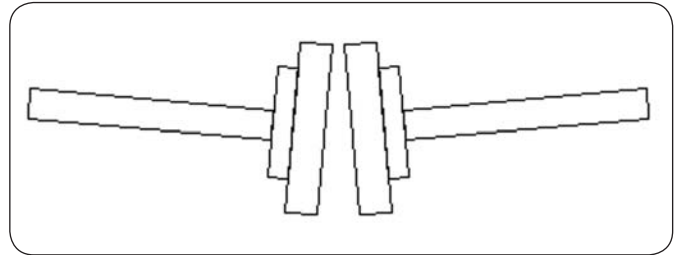

Parallel misalignment

Parallel misalignment occurs when the shaft centerlines are parallel but displaced from one another.

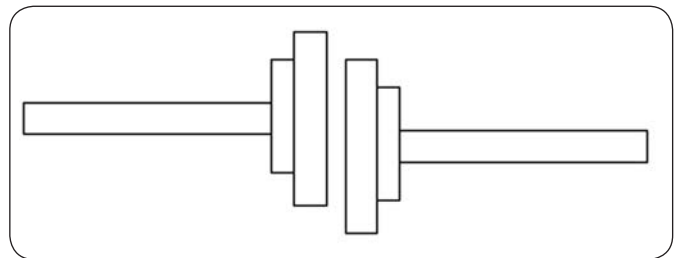

Causes

Possible causes of misalignment are:

- Thermal expansion due to a process working with heat (as with a turbine). Most machines are aligned cold, then as they operate and heat up, thermal growth causes them to grow misaligned.
- Machine directly coupled not properly aligned.
- Forces transmitted to the machine by piping and support members.
- Foundation uneven, shifting or settling.

Effects

Misalignment usually causes the bearing to carry a higher load than its design specification, which in turn causes bearing failure due to fatigue. Fatigue is the result of stresses applied immediately below the load carrying surfaces and is observed as spalling of surface metal.

Diagnoses

Use overall vibration, FFT spectra and phase measurements to diagnose misalignment problems.

Angular misalignment causes **axial** vibration at the running speed frequency (1x).

Parallel misalignment produces **radial** vibration at twice the running speed frequency (2x).

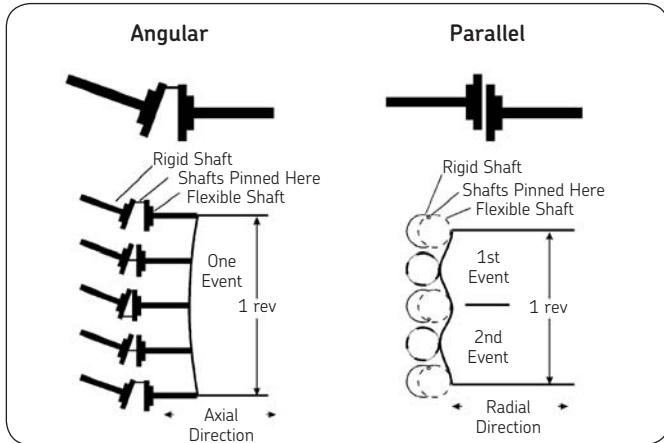

Since most misalignment is a combination of angular and offset, both the radial and axial measurements' 1x and 2x frequencies are analyzed.

Also, while imbalance forces are the same in the horizontal and vertical positions, misalignment forces are seldom the same in both positions.

FFT spectrum analysis

Note: 2x amplitude is not always present.

With misalignment, a higher than normal 1x/2x amplitude may occur. A high 2x amplitude can vary from 30% of the 1x amplitude to 100 to 200% of the 1x amplitude.

Example of a high 2x peak indicating misalignment.

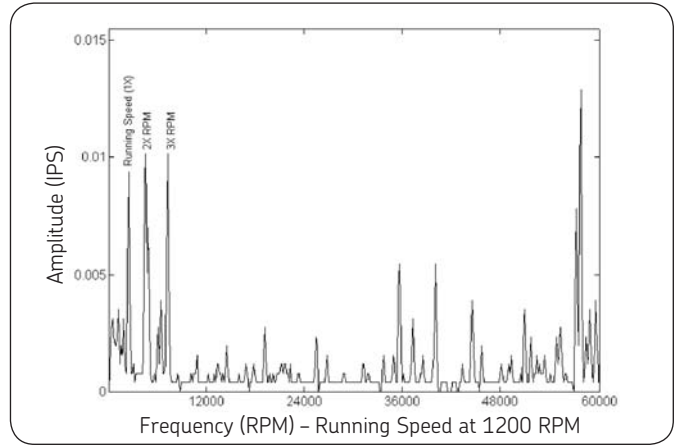
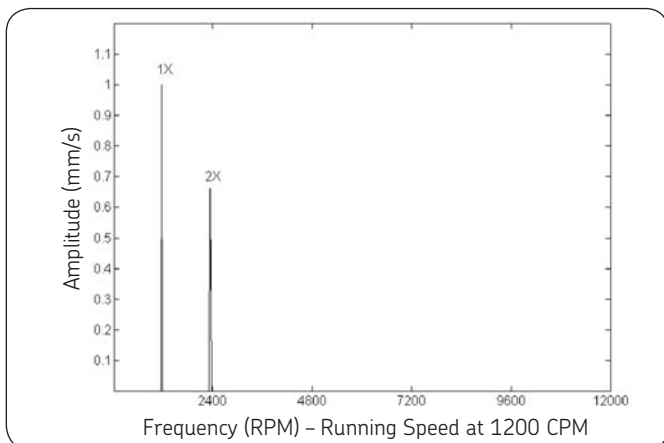

A FFT spectrum showing misalignment.

- Couplings with 2x amplitudes below 50% of 1x are usually acceptable and often operate for a long period of time.
- When the vibration amplitude at 2x is 50 to 150% that of 1x, it is probable that coupling damage will occur.
- A machine whose vibration at 2x running speed is above 150% of the 1x has severe misalignment, the problem should be fixed as soon as possible.

Phase analysis

Phase measurements are a very useful tool for diagnosing misalignment. If possible, measure the phase shift between axial readings on opposite ends of the machine.

Note: All phase values are $\pm 30^\circ$ because of mechanical variance.

Angular misalignment – In the axial position, a phase shift of 180° will exist across the coupling or machine.

Parallel misalignment – In the radial direction, a phase shift of 180° will exist across the coupling or machine. A 0° or 180° phase shift will occur as the sensor is moved from the horizontal to the vertical position on the same bearing.

Combination angular and parallel misalignment – In the radial and axial positions, a phase shift of 180° will exist across the coupling or machine.

Note:

- With severe misalignment, the spectrum may contain multiple harmonics from 3x to 10x.
- If vibration amplitude in the horizontal plane is increased two or three times, then misalignment is again indicated.

SKF monitoring instruments

The following SKF Condition Monitoring instruments may be used to determine misalignment.

SKF Vibration Pen ^{plus} / Picolog

Identify misalignment by measuring the overall vibration values from axial and radial positions on the machine.

- A typical misalignment shows an abnormally higher (or comparable) vibration amplitude in the axial direction compared to the radial direction.
- Imbalance forces are the same in the horizontal and vertical positions. Misalignment forces are seldom the same in both positions. Because of gravity or mounting, imbalance usually produces higher forces in the horizontal plane. If higher than normal forces are present in the vertical plane, misalignment is indicated.

SKF Microlog / SKF Multilog

- Radial and axial overall vibration readings will compare with SKF Vibration Pen ^{plus} and Picolog readings.
- FFT spectra will usually display an abnormally high 1x, 2x or both.
- Phase readings will usually display a 0° or 180° phase shift in the radial positions.

Summary

If there is an abnormally high 2x/1x amplitude and there is a coupling or belt, then there may be misalignment.

If the radial 2x amplitude is abnormally high and there is a coupling or belt, then there may be misalignment.

If the axial 1x amplitude is abnormally high and there is a coupling or belt, then there may be misalignment.

Imbalance

Overview

Experts agree that almost half of all machinery problems are caused by imbalance.

Imbalance occurs when the shaft's mass centerline does not coincide with its geometric centerline. There are three types of imbalance: static imbalance, couple imbalance and dynamic imbalance (a combination of the first two).

Static imbalance

With static imbalance, only one force is involved. To observe this force, place the rotor on a frictionless surface. The rotor turns until the heavy spot is located at six o'clock. The term "static" implies that this type of imbalance can be observed at rest.

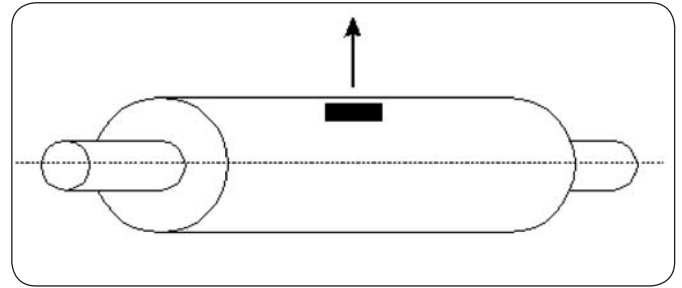

Couple imbalance

Unlike static imbalance, couple imbalance cannot be measured at rest. With couple imbalance, two equal forces (weights) are 180° from each other, causing the rotor to appear balanced at rest. However, when the rotor rotates, these forces move the rotor in opposite directions at their respective ends of the shaft. This causes the rotor to wobble, which produces a 180° out-of-phase reading from opposite ends of the shaft.

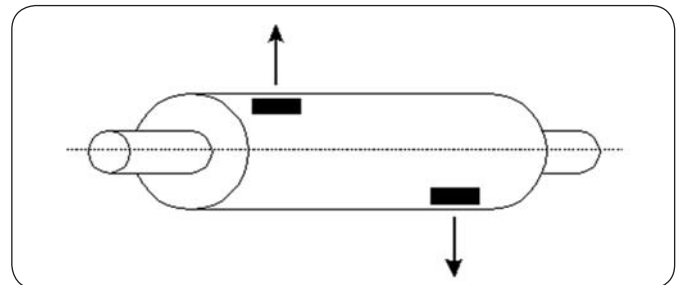

Dynamic imbalance

In reality, almost all imbalance is dynamic imbalance. Dynamic imbalance is the combination of static and couple imbalance. On simple machines, there is usually more static imbalance than couple imbalance. On more complex machinery, with more than one coupling or several spots on the rotor where imbalance can occur, couple imbalance is usually the bigger factor.

When balancing a machine, always balance out the static imbalance first, then take care of the coupling imbalance. When balancing for coupling imbalance, the user is forced to balance in multiple planes.

Cause

Imbalance can be caused by a number of factors, including improper manufacture, an uneven build up of debris on the rotors/vanes/blades, or the addition of shaft fittings without an appropriate counter balancing procedure. With pumps, uneven wear on impellers is indicated as imbalance. Key characteristics of vibration caused by imbalance are:

- It is a single frequency vibration whose amplitude is the same in all radial directions.
- It is sinusoidal, occurring at a frequency of once per revolution (1x).
- The spectrum generally does not contain harmonics of 1x running speed, unless severe.
- Amplitude increases with speed up to the first critical speed of the machine.

Effects

Imbalance usually causes the bearing to carry a higher dynamic load than its design specification, which in turn causes the bearing to fail due to fatigue. Fatigue is the result of stresses applied immediately below the load carrying surfaces and is observed as spalling away of surface metal.

Diagnoses

Use overall vibration, FFT spectra and phase measurements to diagnose imbalance problems.

FFT spectrum analysis

Vibration caused by pure imbalance is a once per revolution sinusoidal waveform. On an FFT spectrum, this appears as a higher than normal 1x amplitude. While other faults can produce a high 1x amplitude, they usually produce harmonics as well. In general, if the signal has harmonics above once per revolution, the fault is not imbalance. However, harmonics can occur as imbalance increases or when horizontal and vertical support stiffness differ by a large amount.

Phase analysis

Use phase measurements to help diagnose imbalance problems.

Note: All phase readings are $\pm 30^\circ$ because of mechanical variance.

- Sensor shows 90° phase shift between the horizontal and vertical positions.
- For predominantly static imbalance, there is usually no phase shift across the machine or coupling in the same measurement position.

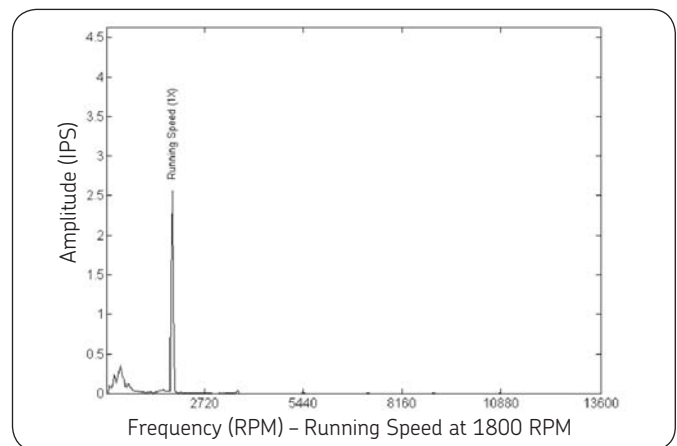
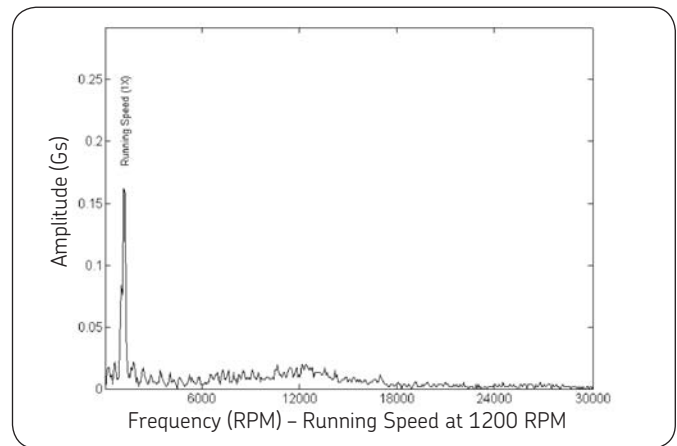
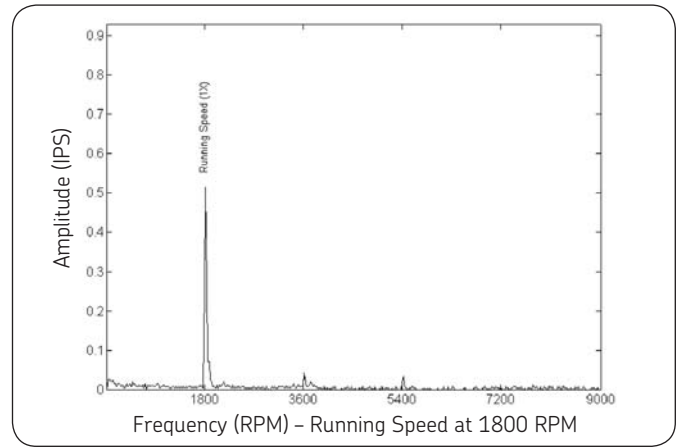

FFT spectrums showing imbalance.

SKF monitoring instruments

The following SKF Condition Monitoring instruments may be used to determine imbalance.

SKF Vibration Pen ^{plus} / Picolog

Identify imbalance by measuring the overall vibration values from axial and radial (horizontal and vertical) positions.

- Typical imbalance shows an abnormally high vibration amplitude in the radial direction compared to the axial direction.
- Imbalance forces are the same in the horizontal and vertical positions. However, because of gravity and mounting, imbalance usually produces higher forces in the horizontal plane.

SKF Microlog / SKF Multilog

Radial and axial overall vibration readings will compare with the SKF Vibration Pen ^{plus} and Picolog readings.

- With pure imbalance, the radial measurements' FFT spectra display a higher than normal 1x amplitude with little or no harmonics.
- For predominantly static imbalance, phase readings normally show a 90° phase shift $\pm 30^\circ$ between the horizontal and vertical positions. There is usually no phase shift across the machine or coupling in the same measurement position.

Summary

- If the radial measurement's 1x amplitude is high and harmonics (except vane passing) are less than 15% of the 1x, then there may be imbalance.
- If the majority of vibration is in the radial plane, and the 1x amplitude is medium to high in amplitude, and the phase from the vertical and horizontal measurements differ by 90°, $\pm 30^\circ$, then there may be imbalance.
- If there is a non-synchronous peak corresponding to the 1x running speed of a coupled machine, then there may be imbalance on the other machine.
- If the primary vibration plane is both axial and radial, and the machine has an overhung mass, and the axial phase measurements across the machine are in phase, then there may be imbalance.

Note: It is important to note increasing imbalance forces place increasing loads on nearby bearings. If the bearing's specified load is exceeded, damage can occur and the bearing's life will be drastically reduced.

Looseness

Overview

Mechanical looseness, or the improper fit between component parts, is generally characterized by a long string of rotating frequency harmonics or 1/2 rotating frequency harmonics at abnormally high amplitudes.

Note: These harmonics may be sporadic. For example, looseness may display peaks at 2x, 3x, 4x, 5x, 6x, etc., or at 3x, 3.5x, 4x, 5.5x, 6x, etc.

Causes

Possible causes of wear/looseness are:

- The machine has come loose from its mounting.
- A machine component has come loose.
- The bearing has developed a fault that has worn down the bearing elements or the bearing seat.

Effects

- If the looseness is bearing related, the effects are the same as imbalance, only more severe.
- If looseness is generated from a component (for example, a fan blade), there is a possibility the part will become detached, causing secondary damage.

Diagnosis

Use FFT spectra and phase to diagnose looseness.

Spectrum analysis

Following are spectral examples of wear/looseness as it "typically" appears on the SKF Microlog or SKF Multilog system.

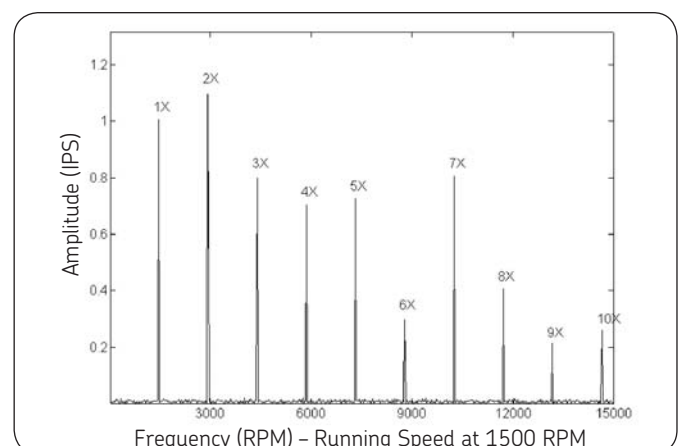

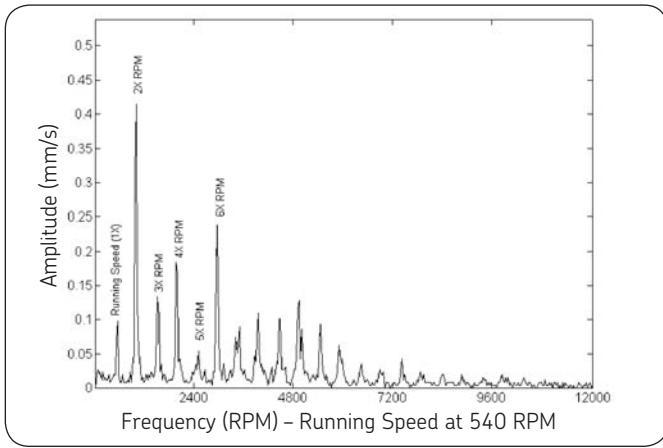

Typically, looseness is identified by an abnormally high running speed amplitude followed by multiples or 1/2 multiples. Harmonic peaks may decrease in amplitude as they increase in frequency (except at 2x, which, when measured in the vertical position, can be higher in amplitude).

Summary

- If there are a series of three or more synchronous or 1/2 synchronous multiples of running speed (range 2x to 10x), and their magnitudes are greater than 20% of the 1x, then there may be mechanical looseness.
- If the machine is rigidly connected (no coupling or belt), and the radial 2x is high, then there may be mechanical looseness.

Bent shaft

With overall vibration and spectral analysis, a bent shaft problem usually appears identical to a misalignment problem. Phase measurements are needed to distinguish between the two.

Causes

- Cold bow – As a result of gravity, a shaft with a high length to width ratio can, at rest, develop a bend.
- Improper handling during transportation
- High torque

Effects

As with imbalance, a bent shaft usually causes the bearing to carry a higher dynamic load than its design specification, which in turn causes the bearing to fail due to fatigue.

Diagnosis

Use overall vibration measurements, spectral analysis and phase measurements to diagnose a bent shaft.

Spectrum analysis

A bent shaft typically produces spectra that have misalignment type characteristics. A higher than normal 1x/2x amplitude may occur. A high 2x amplitude can vary from 30% of the 1x amplitude to 100 to 200% of the 1x amplitude.

Phase analysis

Phase measurements are essential when diagnosing a bent shaft.

Note: All phase values are $\pm 30^\circ$.

- Radial phase measurements (vertical and horizontal) typically appear “in phase”.
- Axial phase measurements are typically 180° out of phase.

If both the above conditions are true, the problem is probably a bent shaft.

Summary

- If the primary vibration plane is in the axial direction, and there is a dominant 1x peak, and there is a 180° phase difference in the axial direction across the machine, then there may be a bent shaft.

Bearing cocked on a shaft

Like misalignment, a cocked bearing usually generates considerable axial vibration. However, phase measurements from the axial position help differentiate the two.

If the phase readings among the four sensor locations vary considerably, a cocked bearing is indicated.

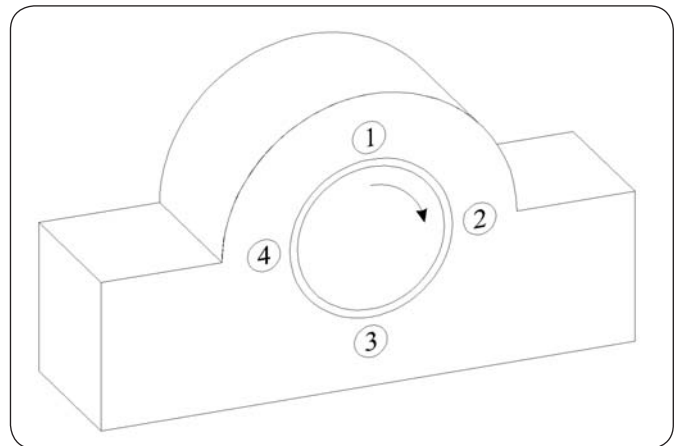

Bearing defects

Note: It is important to reiterate that most often the bearing defect is not the source of the problem. Usually, some other machinery problem is causing the bearing defect. When a bearing defect is detected, you should automatically look for other fault symptoms, like misalignment and imbalance, and schedule the repair of both the defective bearing and the fault causing the bearing defect.

Bearing defect life cycle

In order to understand how to monitor bearings, you must first understand how a bearing defect progresses.

Note: The following discussion relates to typical spall or crack type bearing defects on rolling element bearings.

A bearing may fail for a number of reasons: ineffective lubrication, contaminated lubrication, heavier loading than anticipated, improper handling or installation, old age (surface fatigue), etc.

Often, initial bearing fatigue results in shear stresses cyclically appearing immediately below the load carrying surface. After a time, these stresses cause cracks that gradually extend up to the surface. As rolling elements pass over these cracks, fragments break away. This is known as spalling or flaking. The spalling progressively increases and eventually makes the bearing unusable. This type of bearing damage is a relatively long, drawn-out process, and makes its presence known by increasing noise and vibration.

Another type of bearing failure is initiated by surface distress. Surface distress causes cracks to form on the surface and grow into the material. Surface distress is usually caused by excessive load or improper lubrication.

In both cases, the failing bearing produces noise and vibration signals that, if detected, usually gives the user adequate time to correct the cause of the bearing problem or replace the bearing before it fails completely.

Since SEE technology measures the ultrasonic noise (acoustic emissions) created when metal deteriorates, it is the best tool for detecting bearing problems in their earliest stages, when the defect is subsurface or microscopic and not causing any measurable vibration signal. For that matter, SEE measurements detect any machine condition that produces acoustic emissions, such as lack of lubrication, contaminated lubrication, corrosion and friction due to fretting, cavitation, sliding or friction events, etc.

When a local defect, as a spall or crack occurs and is over-rolled by the bearing's rolling elements, enveloping becomes an effective measurement to detect and monitor bearing failure in its early stages (long before final failure). Again, this provides enough pre-warning time to possibly correct the cause of the bearing problem (be it lubrication, excessive load or process related) and thus potentially correct or minimize the problem, effectively extending the bearing's life.

Note: A bearing's stiffness can affect its enveloping signals. For example, if a bearing is very heavily loaded, repetitive vibration energy is small and enveloping measurements become less effective.

Acceleration and velocity vibration measurements are useful tools for measuring the final stages of a bearing's life. These measurements typically provide indications of imminent bearing failure (less than 10% of residual bearing life).

Vibration analysis

As previously mentioned, there are many machinery problems that can contribute to bearing failure. The most prevalent are excessive load caused by misalignment and/or imbalance, and lubrication problems (lack of lubrication, improper lubrication, excessive lubrication and contaminated lubrication). Others include:

- Defective bearing seats on shafts and in housings
- Faulty mounting practice
- Incorrect shaft and housing fits
- Vibration while the bearing is not rotating
- The passage of electric current through the bearing

Velocity vibration measurements are typically performed on most machinery. These measurements are very useful for detecting and analyzing low frequency rotational problems such as imbalance, misalignment, looseness, bent shaft, etc.

Vibration – numerical analysis

The following chart illustrates the ISO 2372 Standard for vibration severity.

Vibration Severity	Velocity Range Limits and Machinery Classes ISO Std. 2372-1974			
	Small Machines	Medium Machines	Large Machines	
	Class I	Class II	Rigid Supports Class III	Flexible Supports Class IV
0.011	good	good	good	good
0.018	good	good	good	good
0.028	good	good	good	good
0.044	satisfactory	satisfactory	satisfactory	satisfactory
0.071	satisfactory	satisfactory	satisfactory	satisfactory
0.110	unsatisfactory	unsatisfactory	unsatisfactory	unsatisfactory
0.177	unsatisfactory	unsatisfactory	unsatisfactory	unsatisfactory
0.28	unsatisfactory	unsatisfactory	unsatisfactory	unsatisfactory
0.44	unsatisfactory	unsatisfactory	unsatisfactory	unsatisfactory
0.71	unacceptable	unacceptable	unacceptable	unacceptable
1.10	unacceptable	unacceptable	unacceptable	unacceptable
1.77	unacceptable	unacceptable	unacceptable	unacceptable
2.79	unacceptable	unacceptable	unacceptable	unacceptable

Vibration – spectral analysis

Because bearing defects occur at much higher frequencies and much lower amplitudes, ISO severity charts are little help for detecting early bearing problems. For bearing problems, special attention must be given to the bearing's FFT spectrum's bearing defect frequencies.

To assist in determining if a machine's problems include a faulty bearing, the defect frequencies of the bearing can be calculated and overlaid on the vibration spectra.

- F_{ord} = Frequency Outer Race Defect
- F_{ird} = Frequency Inner Race Defect
- F_{bd} = Frequency Ball Defect
- F_c = Frequency Cage

When the defect frequencies (F_{ord} , F_{ird} , F_{bd} , F_c) align with peak amplitudes in the vibration spectrum, there is probably a bearing defect.

Note:

- F_{ord} = BPFO
- F_{ird} = BPFI
- F_{bd} = BPF
- F_c = FTF

Note: SKF offers the Frequency Analysis Module (FAM) software that automatically superimposes defect frequencies for most types of bearings on PRISM² spectra. This aids greatly when analyzing spectra for bearing defects.

If bearing analysis software is not available, bearing defect frequencies should be mathematically calculated.

- $F_{ord} = (n) / 2 \xi (RPM) / 60 \xi (1 - Bd / Pd \xi \cos \theta)$
- $F_{ird} = (n) / 2 \xi (RPM) / 60 \xi (1 + Bd / Pd \xi \cos \theta)$
- $F_{bd} = (n) / 2 \xi (RPM) / 60 \xi [1 - (Bd / Pd)^2 \xi \cos^2 \theta]$
- $F_c = 1 / 2 \xi (RPM) / 60 \xi (1 - Bd / Pd \xi \cos \theta)$

Where:

- (n) = number of balls
- Bd = ball diameter
- Pd = pitch diameter
- θ = contact angle

The following velocity vibration spectrum shows a typical bearing defect in its final stages. The size and width of the "hump" at $\approx 6x$ running speed indicates that the defect has grown and is approaching failure. In very early stages, this hump may not exist or may appear as non-synchronous peaks.

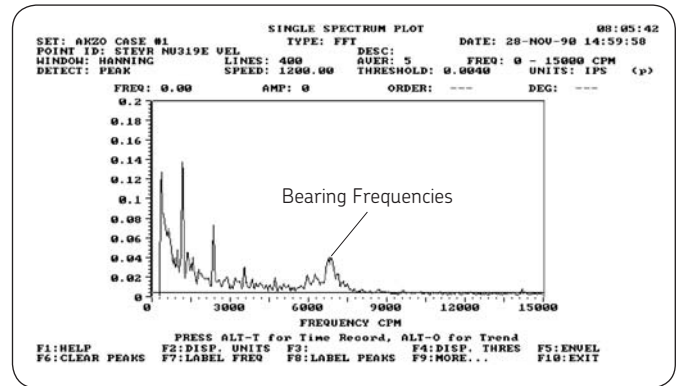

SEE analysis

Depending on the monitoring instrument, SEE technology provides either numerical or spectral output (or both).

SEE numerical analysis

Because SEE signals indicate deterioration in the proximity of the monitoring sensor, a clear understanding of machinery components in the area is essential. For example, if a gearbox is adjacent to the bearing where the SEE measurement is performed, acoustic emissions from the gearbox may add to the bearing's SEE measurement. In this case a high SEE reading may indicate a "good" condition for the monitored bearing.

In general, a "higher than normal" SEE measurement indicates a problem. If no SEE signals are initially present, use the following chart as a guideline for severity of the SEE signal. Numbers are in SEE's.

- 0 to 3: No identifiable problems
- 3 to 20: Lubrication problem, contamination, bearing defect with light load or a small bearing defect with normal load
- 20 to 100: Bearing defect or contamination
- 100+: Severe bearing problem

Again, use these figures as guidelines only. Your measurement trending experience determines valid figures for your SEE monitored machinery.

SEE spectral analysis

Very early, microscopic bearing defects are not visible on normal acceleration or velocity vibration spectra as:

- No vibration yet exists, or
- If vibration does exist, it occurs in the bearing frequency range, which may not be shown by the FFT, and
- It is of such small amplitude that it is hidden by low frequency rotational vibrations.

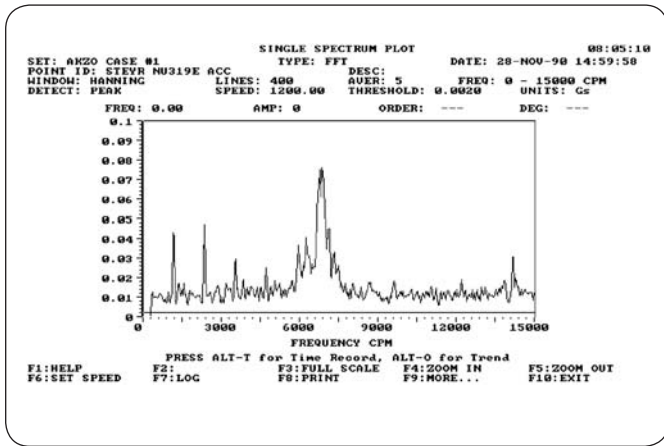

The SEE spectrum of the previously shown velocity measurement peaks in the spectrum represent cage defect.

SEE measurements monitor the ultrasonic frequencies at which these acoustic emissions occur (150 to 500 kHz) and filter out all the low frequency rotational events. The very early bearing defect's repetitive acoustic signals are enhanced and shown as peaks at the defect's frequency. With a bearing, if no peaks exist in the SEE spectra, no acoustic SEE signals are present.

Note: There are non-bearing related instances where SEE spectra do not show obvious peaks, but where the overall level of the SEE spectrum may indicate a problem (for example, cavitation or friction due to fretting).

Acceleration enveloping analysis

Again, depending on the monitoring instrument, acceleration enveloping provides either numerical or spectral output (or both).

Enveloping numerical analysis

When a spall occurs and is over-rolled by the bearing's rolling elements, enveloping becomes an effective measurement to detect and monitor bearing failure in its early stages (long before final failure).

Note: A bearing's stiffness can affect its enveloping signals. For example, if a bearing is very heavily loaded, repetitive vibration energy is small and enveloping measurements become less effective. In cases like this, SEE might be a more useful measurement.

In general, a "higher than normal" enveloping measurement indicates a problem. If no enveloping signals are initially present, use the following tables as guidelines for evaluating the severity of the enveloped value.

Note: Amplitudes are not absolute. The amplitude depends on loading and defect conditions: new, old, etc.

SKF Microlog – SKF Multilog				
	Band I	Band II	Band III	Band IV
Good	0 - 2 mG	0 - 20 mG	0 - 0.2 G' s	0 - 0.5 G' s
Satisfactory	2 - 10 mG	20 - 200 mG	0.2 - 2 G' s	0.5 - 5 G' s
Unsatisfactory	10 - 50 mG	0.2 - 0.5 G' s	2 - 5 G' s	5 - 25 G' s
Unacceptable	50+ mG	0.5+ G' s	5+ G' s	25+ G' s

Handheld probe

For magnetic and permanently mounted probes, the values of Band III are multiplied by two and Band IV by three.

SKF Microlog - SKF Multilog		
	Band III	Band IV
Good	0 - 0.4 G' s	0 - 1.5 G' s
Satisfactory	0.4 - 4 G' s	1.5 - 15 G' s
Unsatisfactory	4 - 10 G' s	15 - 75 G' s
Unacceptable	10+ G' s	75+ G' s

Enveloping spectral analysis

In its early stages, a bearing defect may not be detectable on normal acceleration or velocity vibration spectra, as:

- The vibration occurs in the bearing frequency range, which may not be shown by the FFT, and
- The vibration's amplitude is so small that it is hidden by low frequency rotational vibrations

Enveloping measurements monitor the bearing frequency ranges at which the defect's repetitive impacts occur and filter out all the non-repetitive impact signals (for example, the low frequency rotational events). The repetitive impact signals are enhanced and appear as peaks at the defect's frequency.

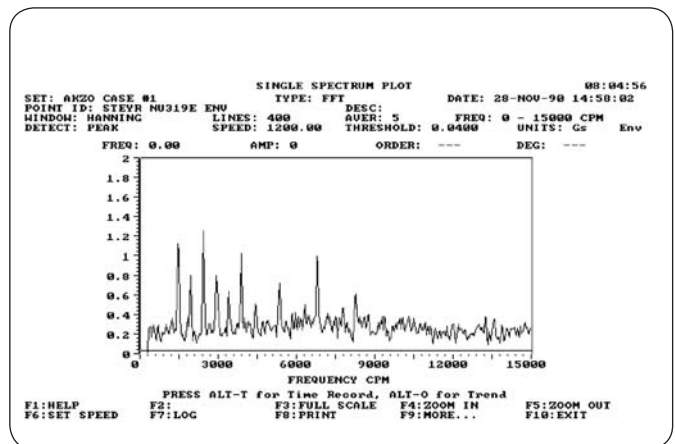

The enveloped spectrum of the previous velocity measurement, again peaks shown represent cage defect.

To assist in determining if a machine's problems include a faulty bearing, the defect frequencies of the bearing can be calculated and overlaid on the vibration spectra.

The acceleration enveloped time domain and spectra (with FAM overlay) for an outer race defect typically appear on the SKF Microlog / SKF Multilog system, as shown below.

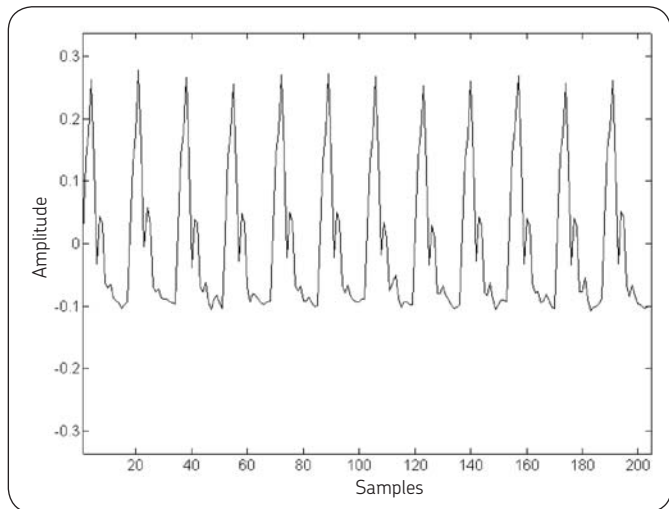

Example of an enveloped time waveform (outer race).

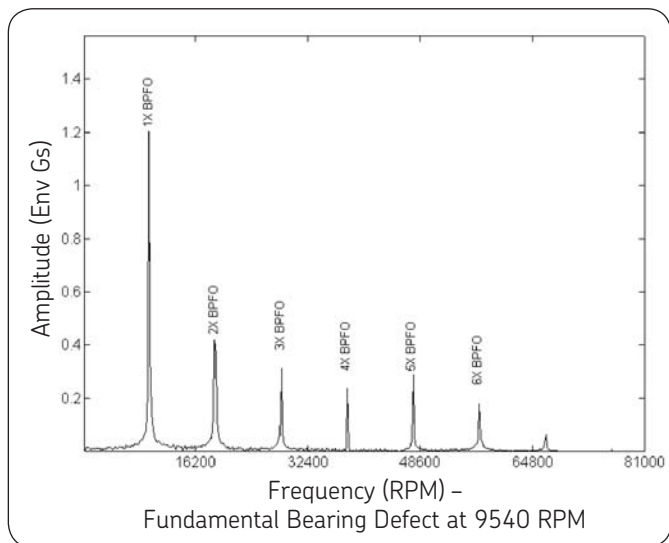

Example of an enveloped spectrum (outer race).

The time domain and spectra for an inner race defect typically appear on the SKF Microlog / SKF Multilog system as shown in the following figure.

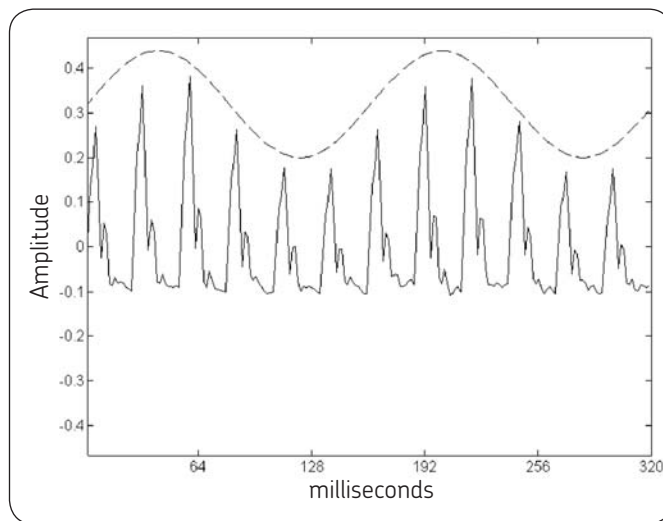

Example of an enveloped time waveform (inner race).

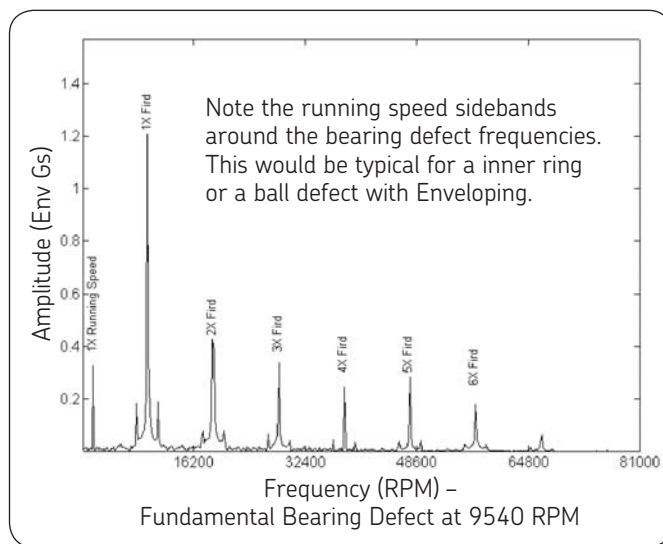

Example of an enveloped spectrum (outer race) for radial loaded bearings.

The difference of between the inner race and outer race displays is the signal modulation caused by the defect rolling in and out of the load zone. For display purposes, we have highlighted this modulation on the inner race time domain plot as a dotted sine wave. The modulation frequency is running speed (1x) and is found at the far left of the FFT spectrum. Ball defects react the same, except the modulation frequency occurs at the cage speed.

These modulation signals appear as sideband spikes on either side of the spectrum peaks. Inner race defects have sideband peaks spaced at shaft rotational speed.

Sometimes with bearing defects there are missing pulses due to the physical randomness of a defect as well as sub-harmonic frequencies (BPF0/2, BPF0/3, etc.).

When the local defect is smaller than the Hertzian contact of the ball to raceway, the signal can be low. The impact depends on the condition of the defect. When the defect grows and the edges fade out, the defect manifestation it is more like a local waviness than an impact, which behaves more like looseness. Thus the enveloping/SEE signal can grow and then lessen as the defect wears. When there is a fresh defect, the signal grows again.

Multi-parameter monitoring

A multi-parameter approach to condition monitoring uses several types of measurement technologies to best detect and diagnose bearing and machinery problems. This allows for early detection of specific machinery problems that may not show under normal monitoring conditions and provides more ways to measure deviations from normal signals. Multi-parameter monitoring has proven very effective for monitoring bearing condition.

For example, if a rolling element bearing has a defect on its outer race, each roller will strike the defect as it goes by and cause a small, repetitive vibration signal. However, this vibration signal is of such low amplitude that with overall vibration monitoring, it is lost in the machine's rotational and structural vibration signals.

Use a multi-parameter approach to best detect bearing problems like the one above.

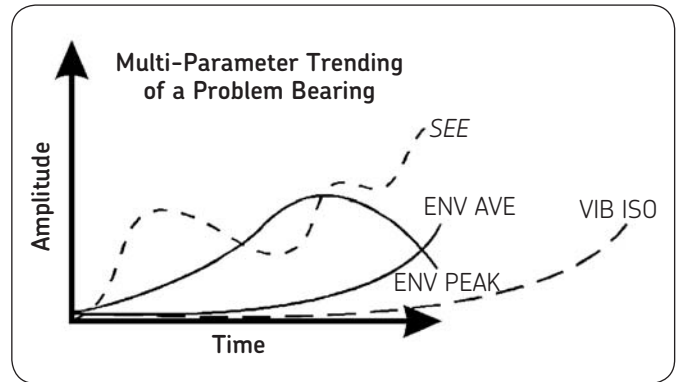

Overall vibration – Monitors low frequency machine vibrations. Detects rotational and structural problems like imbalance, misalignment, shaft bow and mechanical looseness. Detects bearing problems in their later stages.

Enveloping – Filters out low frequency vibration noise and enhances high-frequency, repetitive bearing and gear mesh vibration signals. Has proven very effective for early detection and diagnoses of bearing problems.

SEE – Measures the ultrasonic noise (acoustic emissions) created when metal deteriorates. SEE is the best tool for detecting bearing problems in their earliest stages, when the defect is subsurface or microscopic and not causing any measurable vibration signal. SEE detects any machine condition that produces acoustic emissions, such as lack of lubrication, contaminated lubrication, corrosion and friction due to fretting, cavitation, sliding or friction events, etc.

With bearings, SEE and enveloping technologies provide ample pre-warning time, allowing the maintenance person to take corrective action early enough to effectively extend bearing life.

Appendix A

Understanding phase

Assumptions

For discussion purposes, this setup uses an accelerometer sensor to sense the force of the imbalance, and a tachometer to sense shaft position.

A notch is placed in the rotating shaft. The tachometer generates a pulse when the notch passes the tachometer's position. This pulse initiates data collection.

Definition

The **phase angle** is the angle (in degrees) the shaft travels from the start of data collection to when the sensor experiences maximum positive force.

For example, the phase angle is 90° if the sensor experiences its maximum positive force 90° after data collection was initiated by the tachometer.

Example A

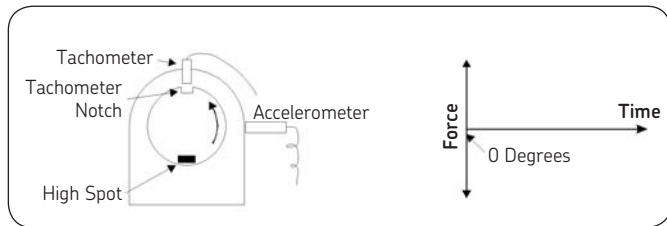

The tachometer senses the notch in the shaft and triggers data collection. At this point, force equals zero.

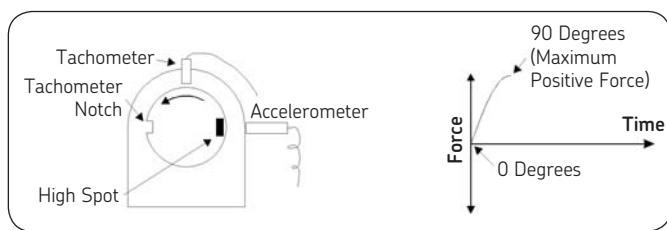

The heavy spot rotates 90° to the sensor position. At this point, the imbalance force produces the highest positive reading from the sensor.

Note: Because the heavy spot is approaching the sensor position, its force is considered to be in the positive direction.

The heavy spot rotates 90° additional degrees, the force experienced by the sensor is zero.

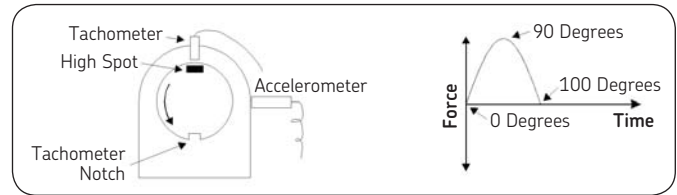

The heavy spot rotates 90° additional degrees, opposite the sensor position. At this point, the imbalance force produces the highest negative reading from the sensor.

Note: Because the heavy spot is moving away from the sensor position, its force is considered to be in the negative direction.

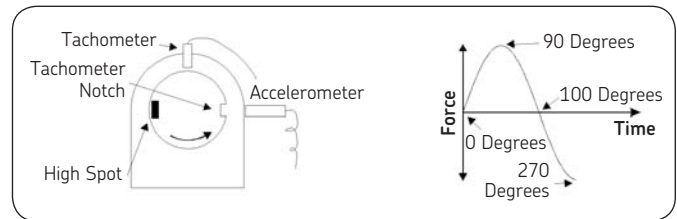

The heavy spot rotates 90° additional degrees to complete its 360° revolution, the force experienced by the sensor is again zero.

Summary

During the 360° shaft revolution, the sensor experiences its maximum positive force when the shaft's heavy spot is 90° from its initial position (its position when data collection was initiated by the tachometer). The phase angle is 90° .

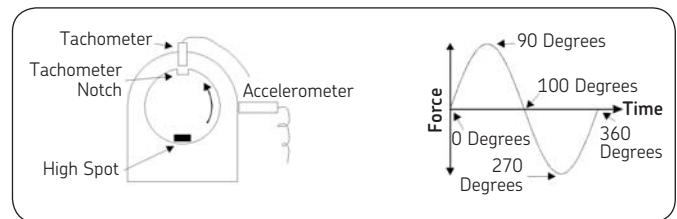

Example B

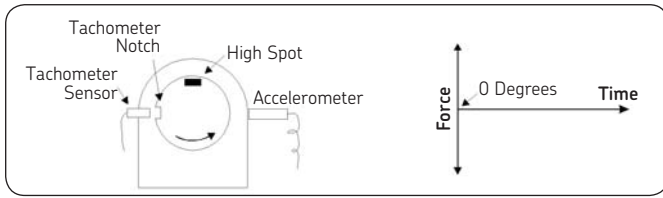

Shaft position at 0°.

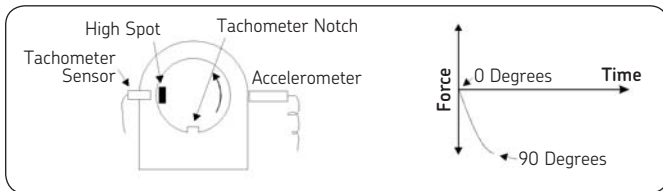

Shaft position at 90°.

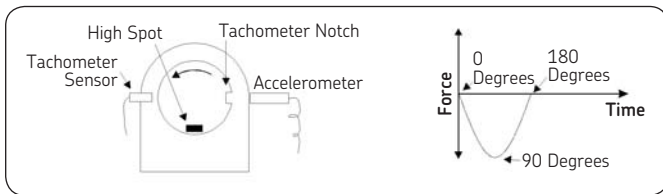

Shaft position at 180°.

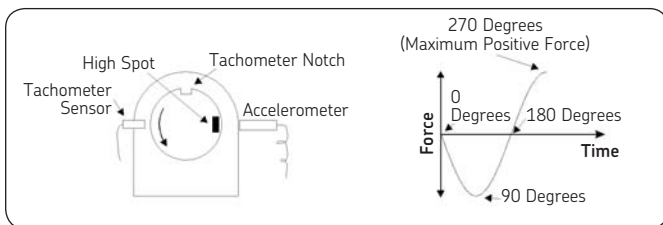

Shaft position at 270°.

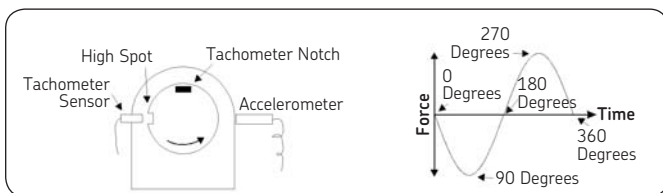

Shaft position at 360°.

Summary

During the 360° shaft revolution, the sensor experiences its maximum positive force when the shaft's heavy spot is 270° from its initial position (its position when data collection was initiated by the tachometer). The phase angle is 270°.

Glossary

1x – The running speed of the machine (fundamental frequency).

2x, 3x, etc. – The frequency at 2, 3, etc., times the running speed of the machine.

Acceleration – The time rate of change of velocity. Acceleration measurements are usually made with accelerometers.

Accelerometer – A sensor whose output is directly proportional to acceleration.

Alarm setpoint – Any value beyond which is considered unacceptable or dangerous to machinery operation.

Alignment – A condition whereby the axes of machine components are either coincident, parallel or perpendicular, according to design requirements.

Amplitude – The magnitude of dynamic motion or vibration. Expressed in terms of peak-to-peak, zero-to-peak or RMS.

Analog-to-digital converter – A device, or subsystem, that changes real-world analog data (as from sensors, for example) to a form compatible with digital (binary) processing.

Asynchronous – Vibration components that are not related to rotating speed (non-synchronous).

Averaging – In a dynamic signal analyzer, digitally averaging several measurements to improve statistical accuracy or to reduce the level of random asynchronous components.

Axial – In the same direction as the shaft centerline.

Axial vibration – Vibration that is in line with a shaft centerline.

Axis – The reference plane used in plotting routines. The X-axis is the frequency plane. The Y-axis is the amplitude plane.

Balancing – A procedure for adjusting the radial mass distribution of a rotor so that the centerline of the mass approaches the geometric centerline of the rotor.

Band-pass filter – A filter with a single transmission band extending from lower to upper cutoff frequencies. The width of the band is determined by the separation of frequencies at which amplitude is attenuated by 3 dB (0,707).

Bandwidth – The spacing between frequencies at which a band pass filter attenuates the signal by 3 dB.

Base-line spectrum – A vibration spectrum taken when a machine is in good operating condition; used as a reference for monitoring and analysis.

Center frequency – For a band pass filter, the center of the transmission band.

Centerline position – The average location, relative to the radial bearing centerline, of the shaft dynamic motion.

Condition monitoring – Determining the condition of a machine by interpretation of measurements taken either periodically or continuously while the machine is running.

CPM – Cycles per minute.

CPS – Cycles per second. Also referred to as Hertz (Hz).

Critical speeds – In general, any rotating speed that is associated with high vibration amplitude. Often the rotor speeds that correspond to natural frequencies of the system.

Cycle – One complete sequence of values of a periodic quantity.

Displacement – The change in distance or position of an object relative to a reference.

Download – Transferring information to the measurement device from the host computer.

Engineering units – Physical units in which a measurement is expressed, such as in./sec, micrometers or mils. Selected by the user.

EU – See *engineering units*.

Fast Fourier Transform – A calculation method of converting a time waveform to a frequency display that shows the relationship of discrete frequencies and their amplitudes.

FFT – See *Fast Fourier Transform*.

Field – One data item. Examples of fields are POINT type, description, etc.

Filter – An electronic device designed to pass or reject a specific frequency band.

Free running – A term used to describe the operation of an analyzer or processor that operates continuously at a fixed rate, not in synchronism with some external reference event.

Frequency – The repetition rate of a periodic event, usually expressed in cycles per second (Hz), cycles per minute (CPM), revolutions per minute (RPM) or multiples of running speed (orders). Orders are commonly referred to as 1x for running speed, 2x for twice running speed, and so on.

Frequency domain – An FFT graph (amplitude versus frequency).

Frequency range – The frequency range (bandwidth) over which a measurement is considered valid. Usually refers to upper frequency limit of analysis, considering zero as the lower analysis limit.

Gap – See *probe gap*.

Gear mesh frequency – The frequency generated by two or more gears meshing teeth together.

Global bearing defect – Relatively large damage on a bearing element.

Hanning window – DSA window function that provides better frequency resolution than the flat top window, but with reduced amplitude accuracy.

Harmonic – A frequency that is an integer multiple of a fundamental frequency. For example, 5 400 r/min is the third harmonic of 1 800 r/min. Harmonics are produced either by an event that occurs multiple times per revolution or by a distortion of the running speed component's pure sine wave.

Hertz (Hz) – Cycles per second. CPM/60.

Hertzian contact zone – In a bearing, the area at which the ball transfers the load on the raceway.

High pass filter – A filter with a transmission band starting at a lower cutoff frequency and extending to (theoretically) infinite frequency.

Imbalance – A condition such that the mass of a shaft and its geometric centerlines do not coincide.

Keyphasor phase reference sensor – A signal used in rotating machinery measurements, generated by a sensor observing a once-per-revolution event. (Keyphasor is a Bently-Nevada trade name.)

Lines – Common term used to describe the filters of a digital spectrum analyzer (e.g., 400 line analyzer).

Low pass filter – A filter whose transmission band extends from an upper cutoff frequency down to DC.

Multi-parameter monitoring – A condition monitoring method that uses various monitoring technologies to best monitor machine condition.

Natural frequency – The frequency of free vibration of a system. The frequency at which an undamped system with a single degree of freedom will oscillate upon momentary displacement from its rest position.

Orbit – The path of shaft centerline motion during rotation.

Overall – A number representing the amount of energy found between two frequencies. The frequency range that the overall is derived from and the type (Average, RMS, Peak, Peak-to-Peak) are usually user selectable.

Overlap processing – The concept of performing a new analysis on a segment of data in which only a portion of the signal has been updated (some old data, some new data).

Peak spectra – A frequency domain measurement where, in a series of spectral measurements, the one spectrum with the highest magnitude at a specified frequency is retained.

Phase – A measurement of the timing relationship between two signals, or between a specific vibration event and a keyphasor pulse.

Phase reference – A signal used in rotating machinery measurements, generated by a sensor observing a once-per-revolution event.

Phase response – The phase difference (in degrees) between the filter input and output signals as frequency varies; usually expressed as lead and lag referenced to the input.

Phase spectrum – Phase frequency diagram obtained as part of the results of a Fourier transform.

POINT – Defines a machinery location at which measurement data is collected and the measurement type.

Position – The average location, relative to the radial bearing centerline, of the shaft dynamic motion.

Probe – An eddy current sensor, although sometimes used to describe any vibration sensor.

Probe gap – The physical distance between the face of an eddy probe tip and the observed surface. The distance can be expressed in terms of displacement (mils, micrometers) or in terms of voltage (millivolts), which is the value of the (negative) DC output signal and is an electronic representation of the physical gap distance. Standard polarity convention dictates that a decreasing gap results in an increasing (less negative) output signal; increasing gap produces a decreasing (more negative) output signal.

Radial – Direction perpendicular to the shaft centerline.

Radial vibration – Vibration which is perpendicular to a shaft's centerline.

Resonance – The condition of vibration amplitude and phase change response caused by a corresponding system sensitivity to a particular forcing frequency. A resonance is typically identified by a substantial amplitude increase and related phase shift.

RMS – The square root of the sum of a set of squared instantaneous values.

ROUTE – A measurement POINT collection sequence.

Run up/Run down – The monitoring of machinery conditions during a start up or shut down process.

Sensitivity – The ratio of magnitude of an output to the magnitude of a quantity measured. Also the smallest input signal to which an instrument can respond.

Sensor – A transducer that senses and converts a physical phenomenon to an analog electrical signal.

Setpoint – See *alarm setpoint*.

Sidebands – Evenly spaced peaks centered around a major peak.

Signal analysis – Process of extracting information about a signal's behavior in the time domain and/or frequency domain. Describes the entire process of filtering, sampling, digitizing, computation and display of results in a meaningful format.

Spectrum – A display of discrete frequencies and their amplitudes.

Spectrum analyzer – An instrument that displays the frequency spectrum of an input signal.

Thermocouple – A temperature sensing device comprised of two dissimilar metal wires that, when thermally affected (heated or cooled), produce a change in electrical potential.

Time domain – A dynamic amplitude versus time graph.

Time waveform – See *waveform*.

Transducer – A device that translates a physical quantity into an electrical output.

Trend – The measurement of a variable (such as vibration) versus time.

Trigger – Any event that can be used as a timing reference.

Upload – Transferring data from the measuring device to the host computer.

Vibration – The behavior of a machine's mechanical components as they react to internal or external forces. Magnitude of cyclic motion; may be expressed as acceleration, velocity or displacement. Defined by frequency and time-based components.

Waveform – A presentation or display of the instantaneous amplitude of a signal as a function of time.

SKF – the knowledge engineering company

From the company that invented the self-aligning ball bearing more than 100 years ago, SKF has evolved into a knowledge engineering company that is able to draw on five technology platforms to create unique solutions for its customers. These platforms include bearings, bearing units and seals, of course, but extend to other areas including: lubricants and lubrication systems, critical for long bearing life in many applications; mechatronics that combine mechanical and electronics knowledge into systems for more effective linear motion and sensorized solutions; and a full range of services, from design and logistics support to condition monitoring and reliability systems.

Though the scope has broadened, SKF continues to maintain the world's leadership in the design, manufacture and marketing of rolling bearings, as well as complementary products such as radial seals. SKF also holds an increasingly important position in the market for linear motion products, high-precision aerospace bearings, machine tool spindles and plant maintenance services.

The SKF Group is globally certified to ISO 14001, the international standard for environmental management, as well as OHSAS 18001, the health and safety management standard. Individual divisions have been approved for quality certification in accordance with ISO 9001 and other customer specific requirements.

With over 120 manufacturing sites worldwide and sales companies in 70 countries, SKF is a truly international corporation. In addition, our distributors and dealers in some 15 000 locations around the world, an e-business marketplace and a global distribution system put SKF close to customers for the supply of both products and services. In essence, SKF solutions are available wherever and whenever customers need them. Overall, the SKF brand and the corporation are stronger than ever. As the knowledge engineering company, we stand ready to serve you with world-class product competencies, intellectual resources, and the vision to help you succeed.



© Airbus – photo: e*im company, H. Goussé

Evolving by-wire technology

SKF has a unique expertise in the fast-growing by-wire technology, from fly-by-wire, to drive-by-wire, to work-by-wire. SKF pioneered practical fly-by-wire technology and is a close working partner with all aerospace industry leaders. As an example, virtually all aircraft of the Airbus design use SKF by-wire systems for cockpit flight control.

SKF is also a leader in automotive by-wire technology, and has partnered with automotive engineers to develop two concept cars, which employ SKF mechatronics for steering and braking. Further by-wire development has led SKF to produce an all-electric forklift truck, which uses mechatronics rather than hydraulics for all controls.

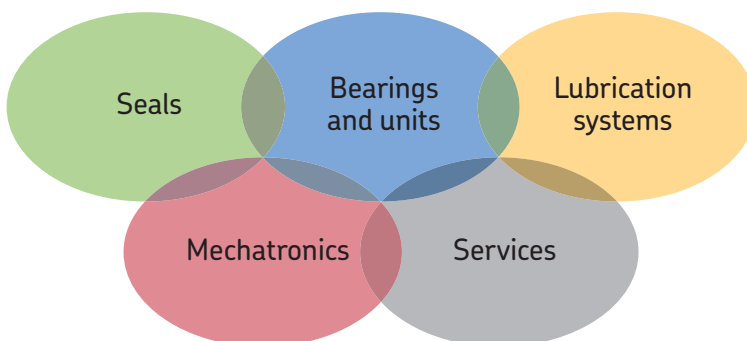



Harnessing wind power

The growing industry of wind-generated electric power provides a source of clean, green electricity. SKF is working closely with global industry leaders to develop efficient and trouble-free turbines, providing a wide range of large, highly specialized bearings and condition monitoring systems to extend equipment life of wind farms located in even the most remote and inhospitable environments.



Working in extreme environments

In frigid winters, especially in northern countries, extreme sub-zero temperatures can cause bearings in railway axleboxes to seize due to lubrication starvation. SKF created a new family of synthetic lubricants formulated to retain their lubrication viscosity even at these extreme temperatures. SKF knowledge enables manufacturers and end user customers to overcome the performance issues resulting from extreme temperatures, whether hot or cold. For example, SKF products are at work in diverse environments such as baking ovens and instant freezing in food processing plants.



Developing a cleaner cleaner

The electric motor and its bearings are the heart of many household appliances. SKF works closely with appliance manufacturers to improve their products' performance, cut costs, reduce weight, and reduce energy consumption. A recent example of this cooperation is a new generation of vacuum cleaners with substantially more suction. SKF knowledge in the area of small bearing technology is also applied to manufacturers of power tools and office equipment.



Maintaining a 350 km/h R&D lab

In addition to SKF's renowned research and development facilities in Europe and the United States, Formula One car racing provides a unique environment for SKF to push the limits of bearing technology. For over 60 years, SKF products, engineering and knowledge have helped make Scuderia Ferrari a formidable force in F1 racing. (The average racing Ferrari utilizes around 150 SKF components.) Lessons learned here are applied to the products we provide to automakers and the aftermarket worldwide.



Delivering Asset Efficiency Optimization

Through SKF Reliability Systems, SKF provides a comprehensive range of asset efficiency products and services, from condition monitoring hardware and software to maintenance strategies, engineering assistance and machine reliability programmes. To optimize efficiency and boost productivity, some industrial facilities opt for an Integrated Maintenance Solution, in which SKF delivers all services under one fixed-fee, performance-based contract.



Planning for sustainable growth

By their very nature, bearings make a positive contribution to the natural environment, enabling machinery to operate more efficiently, consume less power, and require less lubrication. By raising the performance bar for our own products, SKF is enabling a new generation of high-efficiency products and equipment. With an eye to the future and the world we will leave to our children, the SKF Group policy on environment, health and safety, as well as the manufacturing techniques, are planned and implemented to help protect and preserve the earth's limited natural resources. We remain committed to sustainable, environmentally responsible growth.

Please contact:

SKF USA Inc.

Condition Monitoring Center – San Diego

5271 Viewridge Court • San Diego, California 92123 USA

Tel: +1 858-496-3400 • Fax: +1 858-496-3531

Web Site: www.skf.com/cm

© SKF, MICROLOG and MULTILOG are registered trademarks of the SKF Group.

All other trademarks are the property of their respective owners.

© SKF Group 2011

The contents of this publication are the copyright of the publisher and may not be reproduced (even extracts) unless prior written permission is granted. Every care has been taken to ensure the accuracy of the information contained in this publication, but no liability can be accepted for any loss or damage whether direct, indirect or consequential arising out of the use of the information contained herein. SKF reserves the right to alter any part of this publication without prior notice.

SKF Patents include: #US04768380 • #US05679900 • #US05845230 • #US05854553 • #US05992237 • #US06006164 • #US06199422 • #US06202491 • #US06275781 • #US06489884 • #US06513386 • #US06633822 • #US6,789,025 • #US6,792,360 • US 5,633,811 • US 5,870,699 • #WO_03_048714A1

CM5003 EN • May 2011

