

# SKF Multilog On-Line System IMx-C



**User Manual Part No. 32264900-EN**  
**Revision E**

**⚠ WARNING!** *Read this manual before using this product. Failure to follow the instructions and safety precautions in this manual can result in serious injury, damage to the product, or incorrect readings. Keep this manual in a safe location for future reference.*

Copyright © 2016 by SKF Group  
All rights reserved.  
SKF Condition Monitoring Center – Luleå  
Aurorum 30, 977 75 Luleå, Sweden  
Telephone: +46 (0) 31 337 10 00, Fax: +46 (0) 920 134 40



# SKF Group

® SKF is a registered trademark of the SKF Group.  
All other trademarks are the property of their respective owners.  
© SKF 2016

The contents of this publication are the copyright of the publisher and may not be reproduced (even extracts) unless prior written permission is granted. Every care has been taken to ensure the accuracy of the information contained in this publication but no liability can be accepted for any loss or damage whether direct, indirect or consequential arising out of the use of the information contained herein. SKF reserves the right to alter any part of this publication without prior notice.

Patents: US 4,768,380 • US 5,633,811 • US 5,679,900 • US 5,845,230 • US 5,852,351 •  
US 5,854,553 • US 5,854,994 • US 5,870,699 • US 5,907,491 • US 5,992,237 • US 6,006,164 •  
US 6,124,692 • US 6,138,078 • US 6,199,422 • US 6,202,491 • US 6,275,781 • US 6,301,514 •  
US 6,437,692 • US 6,489,884 • US 6,513,386 • US 6,633,822 • US 6,789,025 • US 6,792,360 •  
US 7,103,511 • US 7,697,492 • WO/2003/048714

## Product Support – Contact Information

*Product Support* – To request a [Return Authorization](#), [Product Calibration](#) or a [Product Support Plan](#), use the web page links for direct contact and support.

*Product Sales* - For information on purchasing condition monitoring products, services or customer support, contact your [local SKF sales office](#).

## General Product Information

For general product information (i.e., product data sheet, accessories catalog, etc.), visit the [Condition Monitoring Products](#) page on SKF.com and select the appropriate product link.

## Technical Support Group

Discuss/review issues of specific interest with maintenance and reliability specialists from around the world at the [SKF Knowledge Centre](#).

For technical support, contact [TSG-EMEA@skf.com](mailto:TSG-EMEA@skf.com) for customers in Europe, MiddleEast and Africa.  
Telephone +46 (0) 31 337 65 00  
or [TSG-Americas@skf.com](mailto:TSG-Americas@skf.com) for customers in North America, South America and Asia.  
Telephone +1 800 523 7514  
Telephone in Latin America +55 11 4448 8620

## Product Registration

Please take a moment to register your product at [www.skf.com/cm/register](http://www.skf.com/cm/register) to receive exclusive benefits offered only to our registered customers, including receiving technical support, tracking your proof of ownership, and staying informed about upgrades and special offers. (Please visit our website for more details on these benefits.)

## Tell us how we're doing!

It's important that you're satisfied with the quality of our product user manuals. We appreciate your feedback; if you have comments or suggestions for improvement, [please tell us how we're doing!](#)

032116jg

# Table of Contents

<b>Introduction</b>	<b>1</b>
Important Messages .....	1-1
System Overview.....	1-2
IMx-C Unit .....	1-3
System LED Indicators .....	1-5
<b>Installation</b>	<b>2</b>
Safety and Requirements .....	2-1
Sensor Cables .....	2-2
Cable Glands .....	2-2
Power Supply.....	2-2
Power Fuses.....	2-3
Sensor Power Output.....	2-3
Communication Cable .....	2-4
Data Communication.....	2-4
Ethernet Cable.....	2-4
<b>Unit Configuration</b>	<b>3</b>
Analogue Inputs.....	3-1
Digital Inputs .....	3-3
RS485 Communication.....	3-5
Relays .....	3-6
Network Configuration.....	3-8
IMx-C Time.....	3-10
<b>Hardware Maintenance</b>	<b>4</b>
<b>Electrical Waste</b>	<b>5</b>
<b>Troubleshooting Guide</b>	<b>6</b>
Problems and Symptoms .....	6-1
Component Check .....	6-4
<b>Technical Data</b>	<b>7</b>
Environmental .....	7-1
Power Supply.....	7-1

Analogue Inputs .....	7-1
Digital Inputs .....	7-1
Outputs .....	7-1
Analogue Measurement.....	7-2
Digital Measurement.....	7-2
Signal Processing.....	7-2
Interface.....	7-3
Data Processing .....	7-3
Miscellaneous.....	7-3
Quality Control.....	7-3

**IMx-C Drawings 8**

IMx-C Unit Dimensions .....	8-1
Terminal List.....	8-2

**Limited Warranty A**

**Index**

# 1 Introduction

## Important Messages

---

The following messages are important information which require special care in order to have a safe and reliable IMx-C system.

 **Important messages, instructions and information in this manual must be carefully followed. Otherwise, harm might occur to equipment and/or personnel.**

 **IMx-C unit must be installed by persons qualified to work with electrical instrumentation**

 **IMx-C unit contains circuit boards that are static sensitive. Therefore, use appropriate precautions to prevent ElectroStatic Discharge (ESD) when handling circuit boards.**

 **Make sure that IMx-C is installed in an environment within its specification.**

 **Lightning strikes, power surges and other electrical anomalies can damage IMx-C device.**

 **In order to fulfill fire enclosure requirements the following must be ensured:**

- **The cabinet must always be mounted using all four supplied mounting brackets.**
- **All unused cable ways must be closed with the supplied blind plugs.**
- **All cable glands and blind plugs must be made of material with fire protection V-1 or better.**

 **Important messages related to power supply:**

- *The IMx-C is powered by 24 V DC. Do NOT apply higher voltage.*
- *Make sure that the power is disconnected before the installation.*
- *24 V DC cable must be properly fixed with a cable gland to prevent the cord from strain, twist or move. See [Cable Glands](#) section as well.*
- *High voltage (110 - 240 V AC) power may exist in the same proximity of IMx-C. User caution to avoid contact with any voltage source.*
- *For permanently connected IMx-C, an external all pole power switch must be installed in order to be able to disconnect the IMx-C from the mains power grid. The switch must be labeled "IMx-C" or similar. On/Off position must be clearly marked. The switch must be located close to the IMx-C, within operator's easy reach.*

 **DIP switch settings must be handled with special care to prevent any damage to IMx-C unit:**

- *Do NOT change DIP switch settings while the IMx-C unit is powered-up, as this may cause damage and void warranty.*
- *Before powering up the IMx-C unit, make sure that DIP switch settings are properly set to match the recommendations for the connected sensors. Incorrect settings may cause permanent damage to the IMx-C unit.*

 **The power of IMx-C unit must be turned off before maintenance.**

## System Overview

---

IMx-C is a part of the SKF Multilog On-line System product range. IMx-C is designed to be used as a DAD in a larger customized system or integrated in a machine control box. In conjunction with SKF @ptitude Observer or Analyst software, the IMx-C provides a complete system for early fault detection and prevention, automatic advice for correcting existing or impending conditions and advanced condition-based maintenance to improve machine reliability, availability and performance.

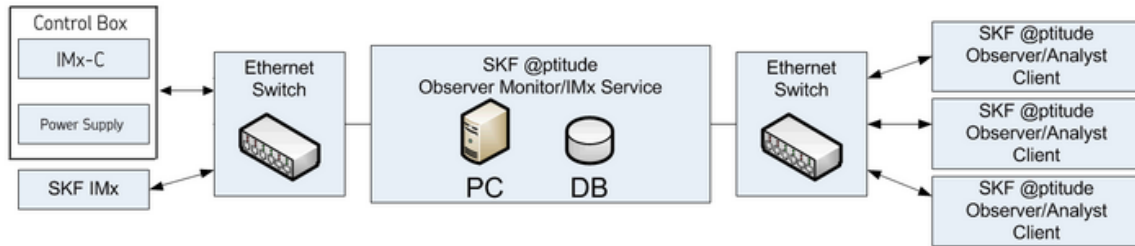

Figure 1 - 1.  
System Overview, IMx-C with @ptitude Observer/Analyst.

The picture above illustrates how IMx-C units are linked together in a network that is connected via a LAN (it may also be a modem) to a SKF @ptitude Observer Monitor or Analyst IMx Service. The @ptitude Observer Monitor or Analyst IMx Service in turn can be connected to e.g. a LAN network making it possible for several of @ptitude Observer or Analyst clients to link to this network.

@ptitude Observer or Analyst clients can also be installed on the same computer as @ptitude Observer Monitor or Analyst IMx Service login software. Through a general interface, also known as ODBC (open database connectivity), it is possible to link @ptitude Observer Monitor or Analyst IMx Service login computer to an existing database for an existing control or processing system, if desired. @ptitude Observer Monitor or Analyst IMx Service, @ptitude Observer or Analyst clients and the database can be separated from each other as long as they are on the same network where ODBC calls can travel freely.

It is also possible to connect different types of on-line units in the same network, for example, IMx-C together with other IMx units and/or MasCon systems.

## IMx-C Unit



Figure 1 - 2.  
SKF Multilog On-line System IMx-C.

## IMx-C

- Up to 16 analogue channels
- Up to 8 digital sensors, where 4 of the digital input channels are configurable for all standard trigger sensors and 4 channels for square pulses with trigger level 12 to 24 V

## Storage Capacity

Each IMx-C unit has 8 MB flash memory used for the following:

- 2 MB for firmware, configuration files, etc.
- 2 MB for trend value buffer
  - About 13 000 vibration trend values can be buffered
  - Speed and process data use half the space of vibration
- 4 MB for spectra and time signal buffer
  - About 250 spectra using 1 600 lines with phase and time signal can be buffered
  - If you use more lines, the number of spectrum is reduced.
  - If you use less lines, the number of spectrum is increased
- When the buffer gets full, the oldest data is thrown away.

## IMx-C Unique Features

- Individual conditions for alert and danger may be set for each measurement point.
- Each channel has indicators for alert and danger. Alert and danger levels may be controlled by machine speed or load. However, it is also possible to manually bypass the alert and danger functionality.
- The unit's unique built-in hardware auto-diagnosis system continuously checks all sensors, cabling and electronics for any faults, signal interruption, short circuits or power failure.

## Initiating IMx-C

Initiating the IMx-C is simple to carry out.

- This is done through an application @plitude On-line Device Configurator or Multilog IMx Configurator tool and a (portable) computer using RS232 serial interface.
- The Dig1 Buffered Output

Each IMx-C has one digital buffered output labeled as Dig1 In Buf Output (a buffered copy of the Dig1 input), as shown in Relay terminal list table, above.

- Dig1 In Buf Output copies and buffers the signal from digital channel 1 labeled as Dig1.



- This output is a low-side switch to GND. (The output does not provide any signal power, just short to GND.)
- This output can be directly connected to a two-wire tachometer input in the other IMx I/O board.
  - Connect Dig1 In Buf Output to Tacho 2-wire input A and connect GND to Tacho 2-wire input B.
- Dig1 In Buf Output and GND are located in last two pins in the relay terminal block.
- The phase of the buffered output has been inverted on I/O board V1.24 and later (DIP21-switch with 6 positions). (The inverted buffered out will have the same phase as connected to an IMx 2-wire input!)
- Network Configuration parameters, such as IP address, IMx identification number, etc. are stored in a separate configuration file first, then transferred to the IMx-C memory. These are retained in the event of power losses, so that the IMx-C can start automatically when power returns.

## **System LED Indicators**

---

IMx-C has two system LED indicators on the CPU card.

- Red LED SYS indicates system fault. On means that system fault has been detected.
  - Note that SYS LED is on for a short time when the system is cold booted or re-started.
- Green LED PWR indicates the status of power. On means that the power is Ok.



## Installation

The installation of an IMx-C must be carried out according to the instructions and advice given in this manual. Any deviation from these directions can be made only after consulting with the SKF Condition Monitoring Center Luleå.

Installation errors can lead to a situation where the system does not work as intended and machinery faults go undetected. Therefore, contact the IMx-C application engineer at the slightest doubt during the installation.

**Note - Installation errors which require the involvement of SKF Condition Monitoring Center Luleå personnel in order to rectify the start of the system, might be debited.**

### Safety and Requirements

---

It is important to assess and evaluate the current site for safety instructions and stipulations.

During the installation work, make oneself acquainted with the valid safety stipulations for the specific machine. Different types of machines can have different safety hazards and safety instructions. In all cases, read the instructions carefully and act accordingly.

 **Important - In order to fulfill fire enclosure requirements, the cabinet must always be mounted using all four supplied mounting brackets.**



IMx-C unit contains circuit boards that are static sensitive. Therefore, use appropriate precautions to prevent ElectroStatic Discharge (ESD) when handling circuit boards.

The following are some of the ways to prevent ESD:

- Use an ESD wrist strap when handling circuit boards
- Use a grounding mat when handling circuit boards
- Use correct packaging materials such as antistatic bags when transferring circuit boards

 **Important - IMx-C unit contains circuit boards that are static sensitive. Therefore, use appropriate precautions to prevent ElectroStatic Discharge (ESD) when handling circuit boards.**

Mount the IMx-C unit and make sure that it is firmly attached at a location where it is not exposed to unnecessary radiant heat or strong magnetic fields.

The ambient temperature can be found in [Environmental](#) section under Technical Data.

## Sensor Cables

---

When routing a sensor cable, it is important that the cable is firmly fixed. The cable may never be allowed to vibrate or oscillate, since this effects the capacitance of the cable, and thereby the measurement result.

The sensor cable may not be routed or bundled together with supply cables since it generates strong magnetic fields.

 **Important - In general, all cables must be routed as far away as possible from the high voltage cables. If this cannot be done, care should be taken to use high quality shielded cables.**

To connect IMx-C to sensors, the following sensor cable type is recommended:

- Shielded, twisted pair 2 x 2 x 0,5 mm<sup>2</sup> (FKAR-PG 2 x 2 x 0.50, DUE 4002 or corresponding)

## Cable Glands

---

The sensor cable shields need to be grounded to IMx-C unit with metallic EMC type cable glands with 360 degree shield. This is recommended for all cable lead-through except the power supply.

 **Important - All unused cable ways must be closed with blind plugs. All cable glands and blind plugs must be made of material with fire protection V-1 or better**

## Power Supply

---

In order to attach 24 V DC power supply, IMx-C must be installed on a grounded metal panel as the diagram below. The brackets must have full contact with the panel.

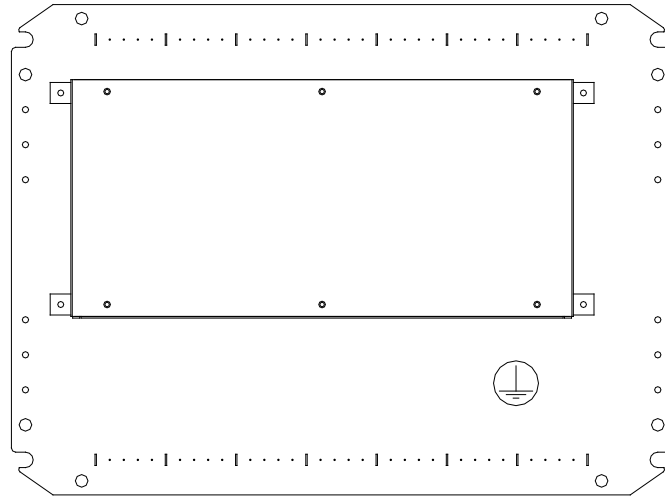

Figure 2 - 1.  
IMx-C Assembly Ground.

**⚠ Important - Make sure that the power is turned off before touching the power cable. Touching the leads of a powered cable can cause serious injuries.**



Figure 2 - 2.  
24 V DC Power Supply Terminals.

Refer to [Power Supply](#) in Technical Data section for power requirements.

## Power Fuses

The 24 V cable into IMx-C (external to IMx-C) must be protected by a slow blow 3,15 A fuse.

## Sensor Power Output

The accumulated current supply of all I/O channels must not exceed 250 mA (a typical ICP sensor consumes circa 4 mA).

## **Communication Cable**

---

It is recommended to use S-FTP (screened shielded twisted pair) Ethernet cable CAT5/6.

It should be grounded with EMC cable gland.

## **Data Communication**

---

IMx-C unit data communications are compliant with the Ethernet standard 10/100 Mbit (half- and full-duplex).

IMx-C has two Ethernet ports which work like an internal network switch.

## **Ethernet Cable**

---

The Ethernet TP cable on the IMx-C is connected at one of the standard Ethernet RJ45 connections. Both Ethernet ports have auto detection of crossover or straight through Ethernet cable connection. Basically, IMx-C has a built-in 2-port Ethernet switches. It is possible to connect several IMx-C units in a daisy chain with up to 8 units in a single cable layout.

There are two LEDs on RJ45 connector.

- Yellow LED is the Ethernet traffic indicator which flickers whenever there is traffic on the network.
- Green LED is the Ethernet link indicator which lights up when the system is correctly connected to another network device.

## Unit Configuration

**⚠ Important - Do NOT change DIP switch settings while the IMx-C unit is powered-up, as this may cause damage and void warranty.**

**⚠ Important - Before powering up the IMx-C unit, make sure that DIP switch settings are properly set to match the recommendations for the connected sensors. Incorrect settings may cause permanent damage to the IMx-C unit.**

### Analogue Inputs

The figure below shows the screw terminal connections for the IMx-C.

**⚠ Important - The sensor shield should be connected either to the sensor or to the IMx-C unit depending on the cable and the sensor type. Which means that the sensor shield can be connected only at one end to avoid ground loops.**

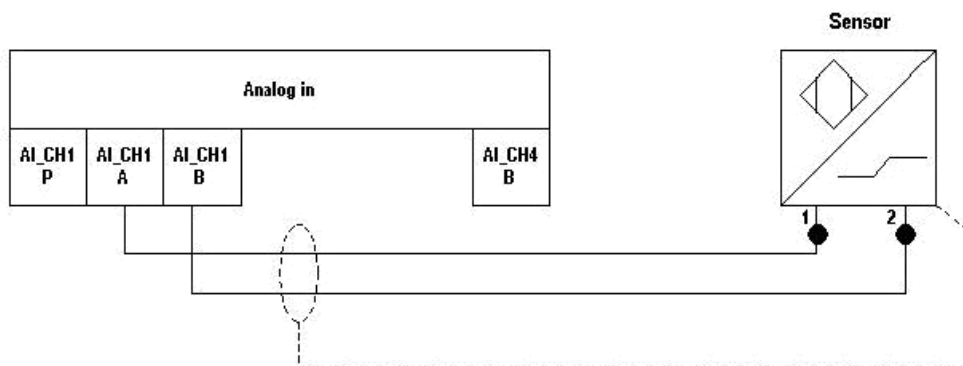

Figure 3 - 1.  
IMx-C Terminal Connection, Standard Accelerometer.

The IMx-C I/O board along with the corresponding analogue terminal list are shown below.

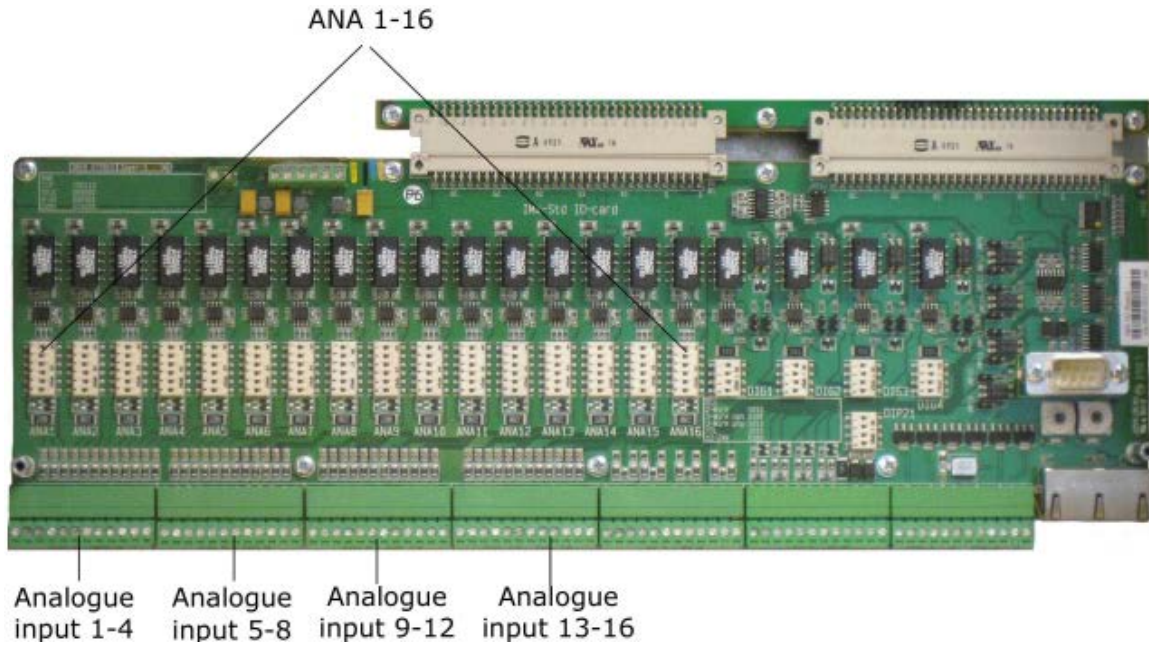

Figure 3 - 2.  
IMx-C I/O board, analogue inputs

**Table 3 – 1. Analogue Terminal List.**

Ana1 Pwr	1
Ana1 A	
Ana1 B	
Ana2 Pwr	
Ana2 A	
Ana2 B	
Ana3 Pwr	
Ana3 A	
Ana3 B	
Ana4 Pwr	
Ana4 A	
Ana4 B	
Ana5 Pwr	13
Ana5 A	
Ana5 B	
Ana6 Pwr	
Ana6 A	
Ana6 B	
Ana7 Pwr	
Ana7 A	
Ana7 B	
Ana8 Pwr	
Ana8 A	
Ana8 B	
Ana9 Pwr	25
Ana9 A	
Ana9 B	
Ana10 Pwr	
Ana10 A	
Ana10 B	
Ana11 Pwr	
Ana11 A	
Ana11 B	
Ana12 Pwr	
Ana12 A	
Ana12 B	
Ana13 Pwr	37
Ana13 A	
Ana13 B	
Ana14 Pwr	
Ana14 A	
Ana14 B	
Ana15 Pwr	
Ana15 A	
Ana15 B	
Ana16 Pwr	
Ana16 A	
Ana16 B	

The DIP switch settings for connected analogue sensors must be applied according to the table below.

**Table 3 – 2. DIP Switch Settings for Analogue Sensors.**

Signal	Terminal		DIP Settings position: 123456
Standard accelerometer (ICP)	N.C. + Signal/Pwr Com.	Pwr A B	100110
Voltage source	N.C. + Signal Com.	Pwr A B	000000
4–20 mA source	N.C. + Signal – Signal	Pwr A B	000001
B-sensor (4–20 mA ouput)	+24 V Signal Com.	Pwr A B	100101



Signal	Terminal		DIP Settings position: 123456
Eddy probe (-24 V)	-24 V Signal Com.	Pwr A B	011000
Voltage powered sensor (max 35 mA)	+24 V Signal Com.	Pwr A B	100100
4-20 mA (IMx powered)	+ Signal - Signal N.C.	Pwr A B	100101

N.C. = Not Connected

DIP switch setting 1 = ON, 0 = OFF

At maximum ambient temperature the total sensor power from all inputs must not exceed 10 W.

At lower temperatures more total sensor power is allowed; please contact SKF Condition Monitoring Center Luleå or application engineer.

## Digital Inputs

The IMx-C I/O board along with the corresponding digital terminal list are shown below.

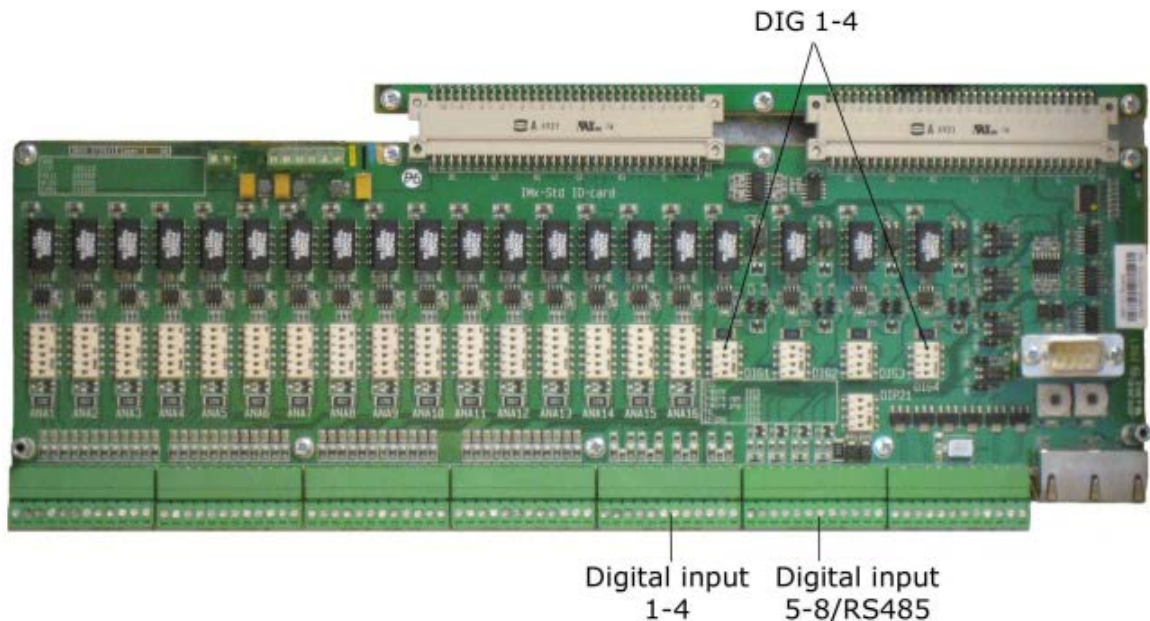

Figure 3 - 3.  
IMx-C I/O board, digital inputs

**Table 3 – 3. Digital Terminal List.**

Dig1 A	49	Dig5 A	61
Dig1 B		Dig5 B	
Dig1 O		Dig6 A	
Dig2 A		Dig6 B	
Dig2 B		Dig7 A	
Dig2 O		Dig7 B	
Dig3 A		Dig8 A	
Dig3 B		Dig8 B	
Dig3 O		N.C	
Dig4 A		RS485 A	
Dig4 B		RS485 B	
Dig4 O		GND	

Digital inputs 1 to 4 (Dig1 to Dig4) are configurable via DIP settings. The DIP settings must be applied according to the table below.

**Table 3 - 4: DIP switch setting for digital sensors.**

Signal	Terminal		DIP Settings position: 1234 (with I/O-board version less than v1.24)	DIP Settings position: 1234 (with I/O board v1.24 or greater, with a hole in front panel for DIP21)
Tacho 2-wire (24 V internally powered, max 30 mA)	+	A	1010	1011
	-	B		
	N.C.	O		
Tacho 3-wire NPN (24 V internally powered, max 30 mA)	Brown (+24 V)	A	0100	0101
	Black (Signal)	B		
	Blue (0 V)	O		
Tacho 3-wire PNP (24 V internally powered, max 30 mA)	Brown (+24V)	A	1010	1011
	Black (Signal)	B		
	Blue (0V)	O		
Pulse 12–24 V (external power)	+	A	0100	0101
	-	B		
	N.C.	O		
Pulse TTL (external power)	N.C.	A	1010	1010
	+	B		
	-	O		

N.C. = Not Connected

DIP switch setting 1 = ON, 0 = OFF

DIP position 4 has no effect on the older I/O board (less than V1.24).

Digital inputs 5 to 8 (Dig5 to Dig8) are non-configurable and sensor power is from external source (trigger level < 12 to 24 V).

They are only used for external signals which are within trigger level 12 to 24 V and square wave signals.

**Table 3 – 5. Digital Inputs 5 to 8 Terminal List.**

Signal	Terminal	
Pulse 12–24 V (external power)	+	A
	-	B

## RS485 Communication

Twisted pair shielded cable shall be used.

 **Important - Connect the shield only at one end to avoid ground loops.**

The cable connection should be done according to the following table.

**Table 3 – 6. Cable Connection.**

IMx-C	RS485 Equipment
RS485 A Out	A
RS485 B Out	B

If the IMx-C unit is at the end or beginning of the RS485 Bus, activate the built-in termination resistor by setting DIP21 switch number 2 to ON. DIP21 can be accessed after the front panel has been taken off. It is located below DIG 3 Dip switch.

**Table 3 – 7. DIP21 Functionality.**

<b>DIP21 settings position: 1234</b>	<b>Functionality with I/O board version less than v1.24 (DIP21-switch with 4 positions)</b>
0100	Termination resistor enabled RS 485
0000	Termination resistor disabled RS 485
<b>DIP21 settings position: 123456</b>	<b>Functionality with I/O-board v1.24 or greater (DIP21-switch with 6 positions)</b>
011010	Termination resistor enabled
001010	Termination resistor disabled

Modbus protocol is used for RS485 communication. IMx-C can be configured as master or slave. However, at the moment IMx-C is only supporting one slave device. If more than one slave device is needed, contact SKF Condition Monitoring Center, Luleå.

For more information regarding RS485/Modbus, refer to "Modbus for IMx & MasCon16 User Manual".

## Relays

The sensor I/O terminals along with the corresponding relay terminal list are shown below.

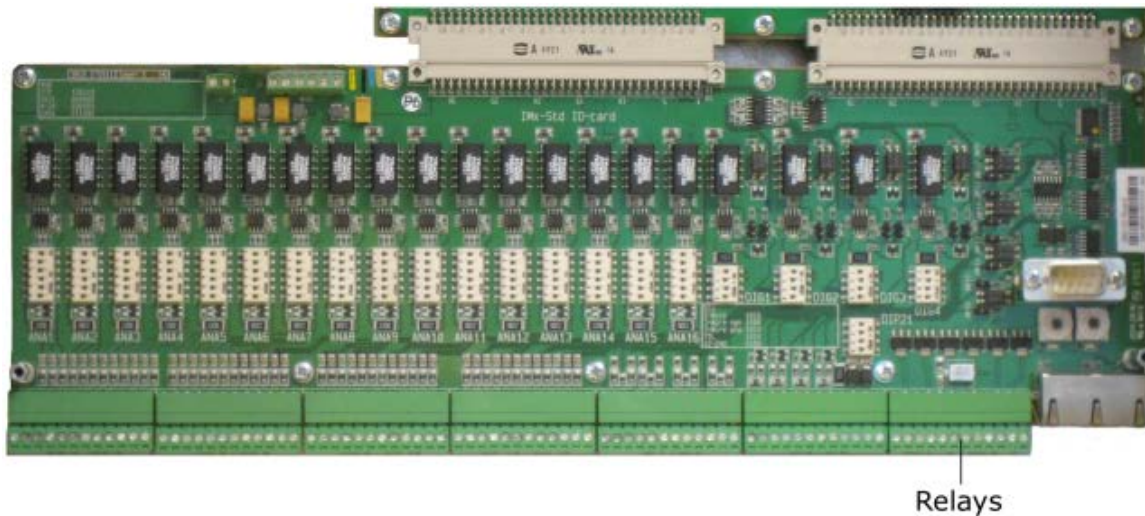

Figure 3 - 4.  
IMx-C I/O Board, Relays.

Table 3 – 8. Relay Terminal List.

Dig +12V	73
Dig1 OUT	
Dig +12V	
Dig2 OUT	
Dig +12V	
Dig3 OUT	
Dig +12V	
Dig4 OUT	
Dig +12V	
SYSTEM OUT	
Dig1 In Buf Output	
GND	

### Software Controlled Relays

Each IMx-C has four software controlled relay driver outputs labeled as Dig1 OUT through Dig4 OUT (see Relay terminal list above). These relay driver outputs can be connected to relays as shown in the figure below.

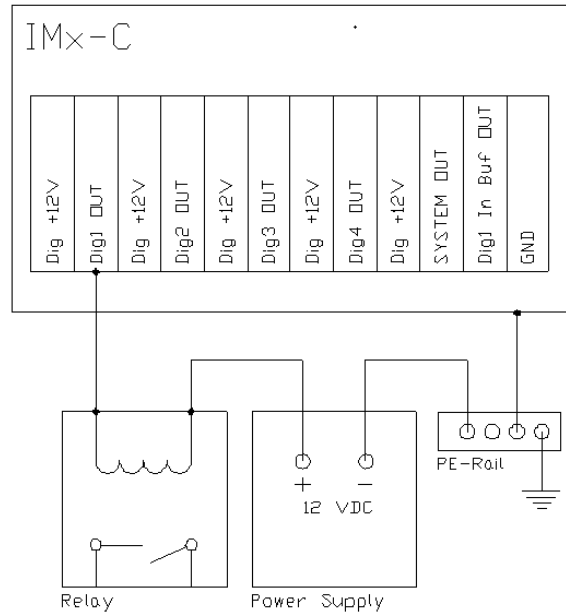

Figure 3 - 5.  
Relay Driver Output Connections.

Note that terminals Dig +12V is not used.

### System Relay Output

The relay output labeled SYSTEM OUT can be connected and used as an external system alarm indicator.

This is a system fault relay that is hardware controlled by watchdog and cannot be configured by software.

The system relay output is always activated when system is Ok.

 Important: +12 V driver shall not be used.

### Dig1 Buffered Output

Each IMx-C has one digital buffered output labeled as Dig1 In Buf Output (a buffered copy of the Dig1 input), as shown in Relay terminal list table, above.

- Dig1 In Buf Output copies and buffers the signal from digital channel 1 labeled as Dig1.
- This output is a low-side switch to GND. (The output does not provide any signal power, just short to GND.)
- This output can be directly connected to a two-wire tachometer input in the other IMx I/O board.
  - Connect Dig1 In Buf Output to Tacho 2-wire input A and connect GND to Tacho 2-wire input B.
- Dig1 In Buf Output and GND are located in last two pins in the relay terminal block.

- The phase of the buffered output has been inverted on I/O board V1.24 and later (DIP21-switch with 6 positions). (The inverted buffered out will have the same phase as connected to an IMx 2-wire input!)

## Network Configuration

---

All IMx-C units must have an identity number between 1 and 255, unique to the database to which it is connected.

It also requires network settings and the IP number and port number of the @ptitude Observer Monitor or Analyst IMx Service to which it should be connected.

Keep in mind that most of the time, all IMx-C units are on the same network and database, therefore units can NOT have the same IP address or the same unit ID.

The network configuration is done through;

- For Observer clients, On-line Device Configurator under SKF @ptitude Monitoring Suite. For detailed information, refer to @ptitude Observer On-line Device Configurator User Manual.
- For Analyst clients, Multilog IMx Configurator in Admin Tools under SKF @ptitude Monitoring Suite.

There are two ways to configure a network and ID configuration:

- by Software: is configured by the software via On-line Device Configurator or Multilog IMx Configurator.
- by Hardware Switches: is done by configuring HEX rotary switches manually.

### Configuration by Hardware Switches

If you have decided to configure the network manually by hardware, the following logic must be fulfilled.

- The factory default configuration TCP/IP address is 10.0.0.1XY.
- The network configuration requires you to set the first three part of the IP address at Create IMx/MasCon16 Config screen of On-line Device Configurator or Multilog IMx Configurator.
- However, the last part of the IP address will be controlled by the HEX rotary switches on the IMx-C unit.
- For example, 10.0.0.1XY, where XY will be derived from HEX rotary switches.
- These last two digits will also form the unit ID.
- The HEX rotary switches are located on the front panel, right hand side marked as HEX1 and HEX2 above Ethernet connectors.
- The HEX rotary switches have to be set manually with a small screwdriver.

**Table 3 – 9. TP/IP Address/Unit ID When Configured by HEX Rotary Switches.**

TCP/IP address/Unit ID	HEX1 (x10)	HEX2 (x1)
Software defined	0	0
01	0	1
02	0	2
↓	↓	↓
99	9	9

Factory default configuration TCP/IP address: 10.0.0.1XY

### Configurator (RS232) Interface

RS232 interface is used only when the required basic network configuration setup is being done.

The RS232 connector is located on the right hand side of IMx-C front panel, labeled as COM.

Use a serial null modem cable with a 9-pin D-SUB connector.

It is recommended to use a short length cable for RS232 interface in order to maintain full communication speed.

 **Important - RS232 connector is used only when the required basic network configuration setup is being done. Therefore, the cable should not be connected to RS232 connector at any other time.**

**Table 3 – 10. RS232 Connector Pinout.**

RS232 Connector Pinout	
Pin	Description
1	N.C.
2	Rx
3	Tx
4	N.C.
5	GND
6	N.C.
7	N.C.
8	N.C.
9	N.C.

N.C. = Not Connected

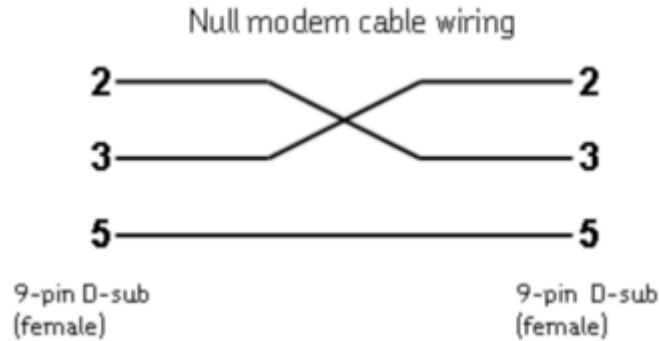

Figure 3 - 6.  
Null Modem Cable Wiring.

---

## IMx-C Time

IMx-C has a backup power capacitor which will keep the time for at least a month if IMx-C is disconnected from a power inlet.

To correct or set IMx-C time, use one of the following methods.

- **Automatic time synchronization**

This method is preferable since IMx-C will continuously synchronize the time with the computer that has @ptitude Observer Monitor or Analyst IMx Service running.

IMx-C uses a built-in function (NTP) in Windows for time synchronization.

In order to activate time synchronization, refer to Time Synchronization chapter in "@ptitude Observer Installation Manual".

- **Manual set time**

Use "Set time" function in @ptitude Observer or @ptitude Analyst application.

In @ptitude Observer, the function is found under a tab menu called "On-line", then "MasCon/IMx units" interface.

In @ptitude Analyst, the function is found at Transfer / Online / Status.



## Hardware Maintenance

The IMx-C hardware, i.e. the IMx-C unit is maintenance free. However, we advise the customers to do a yearly visual inspection of the equipment.



## Electrical Waste



Electrical waste and electrical equipment should be recycled according to the WEEE-directive and not be placed in the general refuse. Product should be sent to an approved recycling center for safe recycling, recovery, reuse or sent to SKF Condition Monitoring Center AB for proper recycling.



SKF Condition Monitoring Center AB  
Aurorum 30  
977 75 Luleå  
Sweden



## Troubleshooting Guide

This Troubleshooting Guide is intended as an aid when IMx-C system is not functioning correctly.

It is designed for instrumentation engineers and others with sufficient knowledge of electrical troubleshooting in electronic systems with a 230 V/110 V power supply and of the risks that this can mean in case of incorrect procedure.

SKF Condition Monitoring Center Luleå strives to provide information that is as accurate as possible. However, SKF Condition Monitoring Center Luleå cannot be held responsible for any injury or damage to persons or material that can occur in the interpretation of, or due to actions taken on the basis of information in this document.

**Note - The guarantee becomes void if IMx-C units are damaged through incorrect intervention in the hardware, or a patently incorrect connection in contravention of directions given.**

### Problems and Symptoms

---

#### **Sensor signal disappears or is abnormally changed for single channels**

Possible causes:

- Broken sensor cable
- Short circuit in sensor cable
- Sensor fault
- Hardware fault with IMx-C input stage
- Grounding loop

Suggested solution:

- Carry out sensor/cable test.

#### **A sensor repeatedly generates a false alarm or varies abnormally**

Possible causes:

- Broken sensor cable/contact
- Incorrectly mounted sensor
- Hardware fault with IMx-C input stage
- Signal disturbed by external noise
- Grounding loop

Suggested solution:

- First carry out sensor/cable test. In addition, check the sensor mounting. If this yields no result, contact SKF Condition Monitoring Center Luleå.

#### **Speed signal unobtainable/faulty for a certain machine**

Possible causes:

- Cable fault (short circuit/broken) to speed sensor
- Faulty speed sensor, or faulty installation
- Speed signal too weak/impedance too high for IMx-C
- Faulty IMx-C speed input
- Incorrect setting in hardware

Suggested solution:

- Test speed input.

#### **Analogue input gives faulty/no signal**

Possible causes:

- Cable fault (short circuit/break) to sensor
- Faulty sensor
- Faulty earthing
- Incorrect setting in hardware
- Faulty IMx-C input

Suggested solution:

- Carry out control of sensor and cabling.

#### **Load input gives faulty/no input signal**

Possible causes:

- Cable fault (short circuit/break) to sensor
- Faulty sensor signal
- Faulty earthing
- Faulty IMx-C load input
- Incorrect setting in software

Suggested solution:

- The load input acts as an analogue input. Therefore, first carry out cabling/input test. Contact SKF Condition Monitoring Center Luleå if this gives no result.

### **IMx-C alarm relay does not activate despite of warning or alarm**

Possible causes:

- Cabling fault from IMx-C to alarm panel
- Configuration error in software
- Hardware fault in IMx-C unit

Suggested solution:

- Check the relay signal.

### **Monitor ceases to work with a certain IMx-C unit**

Possible causes:

- Loss of voltage in IMx-C unit
- Hardware fault in IMx-C unit, such as power supply or processor module
- Break in Ethernet network

Suggested solution:

- Check the voltage of IMx-C unit. In addition, check the Ethernet built-in LED indicator behavior.
- If the problem continues, you may also refer to "Application Note Testing and troubleshooting IMx network connections" in Application notes which is accessible at the top right hand corner of News in Observer screen of @ptitude Observer.

### **Monitor completely ceases to function**

Possible causes:

- Monitor PC non-functional
- Monitor software incorrectly set
- Ethernet switch non-functional
- Cable break in Ethernet network
- Firewall configuration incorrect
- Database non-functional

Suggested solution:

- Refer to "Checking monitor" in Component Check of this chapter.

## Component Check

---

### Checking sensor and sensor cabling for analogue channels

1. Determine the unit number and channel number of the channel in question through the measurement point information in the software, or through the list of terminal blocks.
2. Measure the DC voltage between the sensor wires on the IMx-C terminal block using a digital voltmeter. See the table below for the normal voltage values with and without a connected sensor respectively.

**Table 6 – 1. Normal Voltage.**

Sensor type	Normal operating bias voltage (DC V)	Open circuit voltage (DC V)
Standard accelerometer	8 to 12 V	+24 V

3. Is the voltage within the normal working range?  

YES: The cabling to the sensor is probably Ok, and the sensor electronics have normal input impedance. If the sensor signal is still not perceived to be normal, one should try changing the sensor.

NO: Continue to step 5.
4. Does the fault remain after changing the sensor?  

YES: The fault may be in the analogue input section of the IMx-C unit. Contact SKF Condition Monitoring Center Luleå for service and further information.

NO: Sensor fault. The sensor is defective and must be replaced.
5. Is the voltage close to zero (typical <math>\pm 0.5\text{ V}</math>)?  

YES: There is probably a short circuit in the cable, or the sensor is defective. First, verify that the voltage rises to normal open circuit voltage when one of the sensor cable poles is disconnected from the terminal block of the IMx-C unit.

NO: Continue to step 9.
6. Did the voltage rise to normal open circuit voltage?  

YES: Continue to step 8.

NO: The sensor is not receiving power, continue below.
7. Is the sensor a standard type?  

YES: These are powered internally from the IMx-C unit. If the IMx-C unit does not supply open circuit voltage with input open, then the IMx-C input is probably damaged, or the input is not configured to supply a power feed to the sensor. Verify the DIP switching. If DIP switching is not the problem, contact SKF Condition Monitoring Center Luleå.



8. The fault is in the sensor cable or the sensor. Go out to the sensor, and disconnect the cable at this end. Reconnect the cable on the IMx-C terminal block, and again measure the voltage over these two poles. Does the short circuit remain?  
YES: The sensor cable (or contact) has a short circuit. Repair the cabling.  
NO: The sensor is defective. Replace the sensor.
9. Is the voltage close to the open circuit voltage (+24 V)?  
YES: There is a break in the cable or the sensor is damaged. Continue to step 10.  
NO: If the voltage appears to be neither within the normal working range, close to zero nor close to open circuit voltage, then the fault is an unusual one. First, check that the measurement was correctly carried out, then contact SKF Condition Monitoring Center Luleå. Remaining faults can be due to a damaged sensor or a damaged IMx-C input. First, disconnect one pole of the sensor cable, and measure the open circuit voltage to verify whether the open circuit voltage is normal. If it is normal, then the fault is probably in the sensor, otherwise the fault is in IMx-C.
10. Disconnect the connector from the sensor and short circuit the pins in the sensor contact, then remeasure the voltage on the IMx-C terminal block. Did the voltage sink to close to zero (<0.5 V)?  
YES: There is an internal break in the sensor, or the contact is oxidized. First, try cleaning the contact before replacing the sensor.  
NO: There is a break in the cable. Repair the cabling.

**Checking sensor and sensor cabling for analogue channels from application side**

1. Determine the unit number and channel number of the channel in question through the measurement point information in the software, or through the list of terminal blocks.
2. Measure the DC voltage between the sensor cable poles on the IMx-C terminal block using a digital voltmeter.
3. Does the terminal block have the expected voltage level (see sensor sensitivity and the current actual value of the measured object)?  
YES: The sensor and cabling are probably Ok. If the actual value is still not perceived to be normal, then the fault is probably in the channel settings, or there is a hardware fault in the IMx-C unit. Continue below.  
NO: Continue to step 5.
4. Check through the current settings for the channel in question in the software. Determine the amplification, zero level, and the conversion to the user's unit. Furthermore, the cable check must be off (N). If this still does not produce the correct actual value, then the input card is probably damaged. Contact SKF Condition Monitoring Center Luleå.

5. The cable or the sensor is probably damaged. Test the cabling by disconnecting at the sensor end and connecting e.g. a 1.5 V battery. Does the input now measure the voltage?

YES: The sensor is probably not functioning correctly. However, first check that the channel is correctly configured according to the terminating resistor. In the list of terminal blocks, it can be determined whether the channel in question has a terminating resistor for current circuit. Check that this corresponds in reality, and that it corresponds to the sensor's mode of operation.

NO: The cabling is probably damaged. Continue to step 6.

6. Cable is probably damaged. However, first try disconnecting one of the poles on the cable from the IMx-C terminal block. If the voltage is Ok, then the fault is in the IMx-C unit input stage. Otherwise, the cable is damaged and needs to be repaired.
7. Does the fault remain after replacing the sensor?

YES: The fault can be in the analogue input part of the IMx-C unit. Contact SKF Condition Monitoring Center Luleå.

NO: It is a sensor fault. Replace the sensor.

#### **Checking speed input**

1. Determine the unit number and speed input of the channel in question through the software measurement point setting or through the list of terminal blocks.
2. Measure the signal on the IMx-C terminal block using an oscilloscope or similar. Make sure to use a potential free oscilloscope.
3. Is there an expected speed signal on the IMx-C terminal block?

YES: The signal can be too weak or at too high impedance for the IMx-C speed input to be triggered. Sufficient voltage ripple (peak to peak) is shown in the electrical specifications. If the signal level is sufficient, then the IMx-C input is defective or the software is incorrectly configured. Check the settings in the program for the unit number and input number of the speed measurement point. Contact SKF Condition Monitoring Center Luleå for consultation.

NO: The cable is damaged, or the sensor is not sending the correct output signal. Check that the installation of the sensor is correct (is the machine rotating?). If this produces no result, check the cable. The entire chain from cable to input can be tested by linking a signal generator with a suitable frequency and amplitude at the sensor end. However, note that IMx-C normally supplies power to a sensor (as shown in the equipment list), which is why a coupling capacitor must then be connected in series, to avoid ruining the signal generator.

#### **Checking relay signal**

1. Determine the unit number of the alarming channel through the software measurement point setting or through the list of terminal blocks.
2. Disconnect the relay connection from the IMx-C unit in question. Carefully check to see if the relay output caused to trip the machines. Measure the voltage between the alarm relay poles.

3. Has the relay been activated (voltage approximately 12 V)?

YES: The fault is in the cabling or output connections from IMx-C.

NO: Check the software configuration for measurement point settings to find out whether the channel in question is allowed to activate the alarm relay. If this is not the case, then change the setting. Contact SKF Condition Monitoring Center Luleå, if the channel is permitted to activate the relay, but does not do so.

#### **Checking monitor**

1. Check first, whether the @ptitude Observer Monitor or Analyst IMx Service PC is functioning as it should be.
2. Try restarting the computer, if there is any doubt as to the status of the @ptitude Observer Monitor or Analyst IMx Service software.
3. Check also that the Ethernet network is functioning and that the Observer Monitor or Analyst IMx Service computer can write to the server disk.

#### **Checking Modbus sensor**

1. Start @ptitude Observer On-line Device Configurator located in the @ptitude Observer directory.
2. Click **Start serial interface**.
3. On the Serial interface screen, enter the COM port number and type in the word "modbus" in the command box.
4. Statistics on communication and the contents of the import registers will appear on the screen. The statistics are:
  - Frame errors (short and long)
  - Checksum errors
  - The number of messages sent
  - The number of messages received
  - The number of timeouts of requests
5. A properly working Modbus communication should exhibit increasing sent and received messages, but not exhibit significant increase of errors or timeouts.
6. In case of errors or timeouts, check that all of the following are correctly installed:
  - Physical connections of RS485 cable wires are done correctly
  - Transmission characteristics are defined correctly
  - The Modbus Master-Slave pair address is entered correctly
  - RS485 termination is done correctly
7. This process of checking Modbus sensor can be done several times during the test to diagnose the communications or lack of it.



### Environmental

---

- Size (H X W X D):
  - 170 X 358 X 120 mm (6.7 X 14.1 X 4.7 in.) without mounting brackets
  - 170 X 387 X 120 mm (6.7 X 15.24 X 4.7 in.) with mounting brackets
- Weight: 4 kg (8.8 lbs.)
- IP rating: IP 20
- Temperature range: -30 to +70 °C (-20 to +160 °F)
- Maximum altitude: 2 000 m (6 561.7 ft.)

### Power Supply

---

- 24 V DC (20 to 28 V DC)
- Power consumption: 30 W

### Analogue Inputs

---

- 16 Analogue differential inputs
- Individual 24 V power supply, maximum 35 mA per channel
- Selectable standard accelerometer power supply (4 mA)
- Input range:  $\pm 25$  V
- Impedance: >100 k $\Omega$

### Digital Inputs

---

- Eight digital opto-isolated inputs
- Four channels with individual 24 V power supply, maximum 30 mA per channel

### Outputs

---

- Four relay contacts
- One system relay output

## **Analogue Measurement**

---

- 24-bit AD conversion enabling continuous transient capture (no gain or AC/DC switching necessary)
- 16 channels with true simultaneous sampling (no multiplexing)
- Simultaneous sampling of different channels with different sampling rates
- Frequency range: from DC to 40 kHz
- Dynamic range: 120 dB
- Signal to noise ratio: 90 dB
- Cross-talk rejection: 100 dB
- Accuracy amplitude:  $\pm 2\%$  (up to 20 kHz),  $\pm 5\%$  (20 to 40 kHz)
- Accuracy phase:  $\pm 3^\circ$  (up to 100 Hz)

## **Digital Measurement**

---

- Frequency range: 0,1 Hz to 20 kHz (I/O board V1.24 and later, DIP21-switch with 6 positions)
- Frequency range: 0,1 Hz to 12,5 kHz (I/O board older versions, DIP21-switch with 4 positions)
  - Required pulse width:  $> 4 \mu\text{s}$  for electrical positive  
 $> 40 \mu\text{s}$  for electrical negative
- Accuracy frequency: 0,05% of measurement value (typically 0,01% up to 2,5 kHz)
- Pulse counting

## **Signal Processing**

---

- Time waveform
- Vector analysis with circular alarms
- FFT: 100 to 6 400 lines
- SKF's four enveloping bands
- Integration/Differentiation in frequency domain
- Window function: Hanning
- Customer formulated mathematical equations
- Dynamic alarm levels, active range determined on multiple parameters
- Data storage on time, event or alarm condition
- Data buffering in flash memory when communication link is down

- Detection of sensor and cable fault
- Watchdog and self testing

## **Interface**

---

- Ethernet: 10/100 Mbit RJ45, TCP/IP, switch functionality
- RS232 service interface
- 2-port Ethernet network switch (possible for daisy chaining)
- RS485

## **Data Processing**

---

- 64 MB RAM for data processing (from serial number  $\geq 12000$ )

## **Miscellaneous**

---

- Calibration, traceable to BIPM
- CE certified according to EN61000-6-4 and EN61000-6-2
- Support IEC 61850

## **Quality Control**

---

SKF Condition Monitoring Center, Luleå is ISO 9001:2008 certified.





IMx-C Unit Dimensions

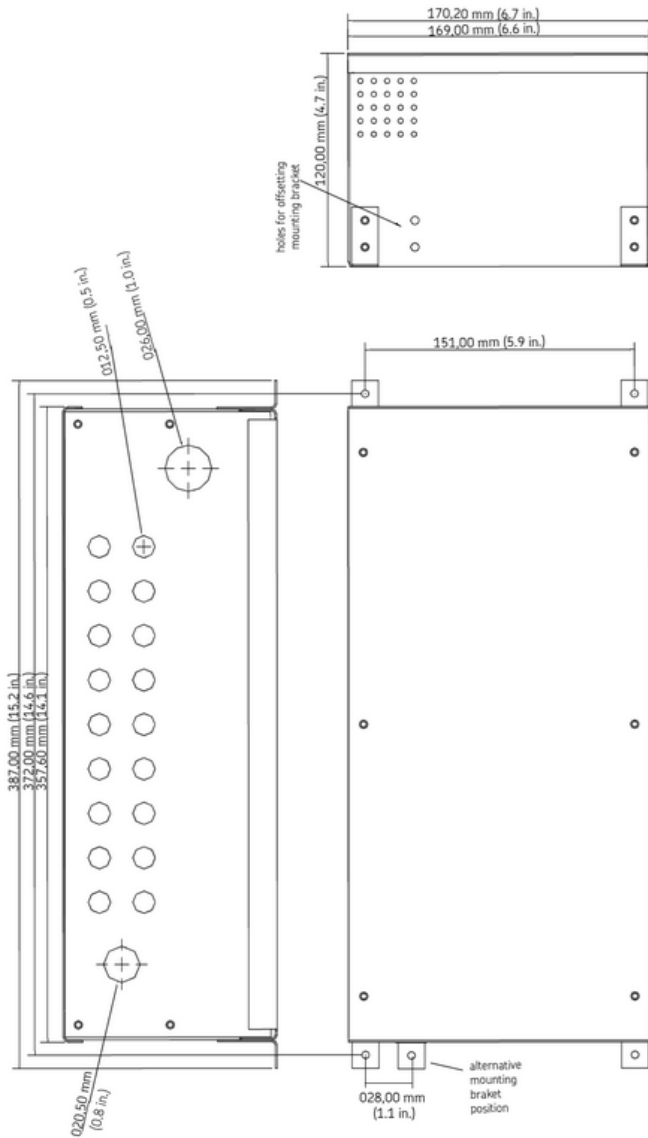

Figure 8 - 1.  
IMx-C Unit Dimensions.

## Terminal List

Table 8 – 1. Terminal List.

Ana1 Pwr	1
Ana1 A	
Ana1 B	
Ana2 Pwr	
Ana2 A	
Ana2 B	
Ana3 Pwr	
Ana3 A	
Ana3 B	
Ana4 Pwr	
Ana4 A	
Ana4 B	
Ana5 Pwr	13
Ana5 A	
Ana5 B	
Ana6 Pwr	
Ana6 A	
Ana6 B	
Ana7 Pwr	
Ana7 A	
Ana7 B	
Ana8 Pwr	
Ana8 A	
Ana8 B	
Ana9 Pwr	25
Ana9 A	
Ana9 B	
Ana10 Pwr	
Ana10 A	
Ana10 B	
Ana11 Pwr	
Ana11 A	
Ana11 B	
Ana12 Pwr	
Ana12 A	
Ana12 B	
Ana13 Pwr	37
Ana13 A	
Ana13 B	
Ana14 Pwr	
Ana14 A	
Ana14 B	
Ana15 Pwr	
Ana15 A	
Ana15 B	
Ana16 Pwr	
Ana16 A	
Ana16 B	
Dig1 A	49
Dig1 B	
Dig1 O	
Dig2 A	
Dig2 B	
Dig2 O	
Dig3 A	
Dig3 B	
Dig3 O	
Dig4 A	
Dig4 B	
Dig4 O	
Dig5 A	61
Dig5 B	
Dig6 A	
Dig6 B	
Dig7 A	
Dig7 B	
Dig8 A	
Dig8 B	
N.C	
RS485 A	
RS485 B	
GND	
Dig +12V	73
Dig1 OUT	
Dig +12V	
Dig2 OUT	
Dig +12V	
Dig3 OUT	
Dig +12V	
Dig4 OUT	
Dig +12V	
SYSTEM OUT	
Dig1 In Buf Output	
GND	

# Appendix A

## Limited Warranty

### SKF – Limited Warranty

#### WARRANTY

Subject to the terms and conditions contained herein and provided that there is no applicable written agreement between the selling entity in the SKF Group (“SKF”) and the Buyer specifically covering the sale of the Products (as defined below) that includes a product warranty, SKF warrants to the Buyer that for the warranty period indicated below the products sold by SKF that are listed below (the “Products”), when properly installed, maintained and operated, will be free from defects in material and workmanship and shall be fit for the ordinary purposes for which the Products are designed.

#### BUYER'S LIMITED REMEDIES

This limited warranty defines SKF's sole and exclusive liability and Buyer's sole and exclusive remedy for any claim arising out of, or related to, any alleged deficiency in any Product sold by SKF, even if such claim is based on tort (including negligence or strict liability), breach of contract, or any other legal theory. If the Product does not conform to this limited warranty, Buyer must notify SKF or SKF's authorized service representative within thirty (30) days of discovery of the nonconformity; provided, however, that SKF shall not be liable for any claim for which notice is received by SKF more than thirty (30) days following the expiration of the applicable warranty period for the Product. Upon receipt of timely notification from Buyer, SKF may, at its sole option, modify, repair, replace the Product, or reimburse Buyer for any payment made by Buyer to SKF for the purchase price of the Product, with such reimbursement being pro-rated over the warranty period.

#### WARRANTY PERIOD

Except as expressly provided below, the warranty period for each Product shall commence on the date the Product is shipped by SKF to Buyer.

#### 90-DAY WARRANTY

Products warranted for ninety (90) days by SKF are as follows: cable assemblies, MARLIN QuickConnect (MQC), magnetic temperature probes, and all refurbished equipment.

#### ONE-YEAR WARRANTY

Products warranted for one (1) year by SKF are as follows: all Microlog products and accessories, all Microlog Inspector applications including hand-held computers, all MARLIN data managers (MDM), all MARLIN Condition Detectors (MCD), all Wireless Machine Condition Detectors (WMCD), all Multilog On-line Systems (IMx), all Multilog Condition Monitoring Units (CMU, TMU), Multilog Local Monitoring Units (LMU), all Multilog Wireless Monitoring Units (WMx), Multilog On-line System Wireless Vibration Transmitter ISA100, all Wireless Monitoring Systems V/T, all Vibration PenPlus, all Machine Condition Advisors (MCA), all Machine Condition Indicators (MCI), all transmitters, all Monitor Interface Modules (MIM), all Machine Condition Transmitters (MCT), all MicroVibes and Custom Products with the prefix of CMCP (with the exception of any consumable or expendable items), Shaft Alignment Systems TKSA 60 and TKSA 80 including hand-held computer, measuring units and accessories.

#### TWO-YEAR WARRANTY

Products warranted for two (2) years by SKF are as follows: all standard Eddy Probes, Eddy Probe Drivers, and Eddy Probe Extension Cables, all Multilog On-line Systems (DMx), all Wireless Machine Condition Sensors, and all M800A and VM600 Machinery Monitoring Systems.

For all On-line Systems (as defined below) that have satisfied Criteria 1 and 2 below, the warranty period shall be either thirty (30) months from the date the On-line System is shipped by SKF to Buyer, two (2) years from the date the On-line System is installed and commissioned by SKF, or two (2) years from the date on which the installation of the On-line System has been audited and commissioned by SKF or its authorized service representative, whichever period ends first.

#### Criteria 1.

Devices used with a Multilog On-line System (IMx), Multilog Condition Monitoring Unit (CMU), Multilog Local Monitoring Unit (LMU), including, but not limited to, the sensing device, the interconnect cabling, junction boxes, if any, and the communications interface, must consist only of SKF-supplied or SKF-approved devices and/or components. The computer provided by Buyer must meet the requirements stipulated by SKF.

#### Criteria 2.

SKF or its authorized service representative has installed the On-line System or has audited the installation and commissioned the On-line System.

“On-line Systems” are defined as systems consisting of Multilog On-line System (IMx), Multilog Condition Monitoring Unit(s) (CMU), Multilog Local Monitoring Unit(s) (LMU), and any sensing or input devices, the interconnect cabling between the sensing or input devices and the Multilog On-line System (IMx), Multilog Condition Monitoring Unit(s) (CMU), Multilog Local Monitoring Unit(s) (LMU), and the cabling between the Multilog On-line System (IMx), Multilog Condition Monitoring Unit (CMU), Multilog Local Monitoring Unit (LMU) and the proprietary SKF communications interface with the host computer.

#### FIVE-YEAR WARRANTY

Products warranted for five (5) years by SKF are as follows: special seismic sensors.

#### LIMITED LIFETIME WARRANTY

Products covered under this Limited Lifetime Warranty (as set forth below) are as follows: standard seismic sensors of the CMSS 2XXX and CMSS 7XX series (accelerometers and velocity transducers) as marked and published in the SKF Vibration Sensor Catalogue.

- (A) Subject to the terms herein, SKF will provide a “Limited Lifetime Warranty” for the products specified above sold by SKF after April 15, 2014. Under the Limited Lifetime Warranty, those products shall, at the time of shipment, be free from defects in material and workmanship. If any of these products fail to meet the terms of this Limited Lifetime Warranty during the life of such products, SKF, in its sole discretion, will repair, replace or exchange the products for the same model if the necessary components for the products are still available to SKF on a commercially reasonable basis. SKF will not provide a Limited Lifetime Warranty on products damaged by accident, abuse, misuse, neglect, improper installation, problems with electrical power, natural disaster, or by any unauthorized disassembly, repair or modification.
- (B) Upon receipt of any product covered by the Limited Lifetime Warranty, SKF will pay all shipping charges to send the repaired, replaced or exchanged product to the original point of shipment. SKF reserves the right to decline repair or replacement if no fault is found in the product.
- (C) For any warranty claim, the original Buyer must provide SKF with the applicable model and serial numbers, the date of purchase, the nature of the

problem, and proof of purchase. SKF, in its sole discretion, will determine if the Buyer must return the product covered under this warranty to SKF.

- (D) The express warranty set forth in the Limited Lifetime Warranty is in lieu of and excludes any and all other warranties express or implied, including, but not limited to, the implied warranties of merchantability and fitness for a particular purpose.
- (E) SKF's sole obligations under this Limited Lifetime Warranty are set forth in paragraphs (A) and (B), and SKF's liability under this Limited Lifetime Warranty shall not exceed the purchase price of the product, plus any shipping and handling charges that SKF may be obligated to pay pursuant to paragraph (B).
- (F) **IN NO EVENT SHALL SKF BE LIABLE OR OBLIGATED TO THE BUYER OR ANY OTHER PERSON FOR SPECIAL, EXEMPLARY, PUNITIVE, INCIDENTAL, DIRECT, INDIRECT, GENERAL OR CONSEQUENTIAL DAMAGES (INCLUDING, BY WAY OF EXAMPLE ONLY, LOST PROFITS OR SAVINGS, LOSS OF BUSINESS OR LOSS OF USE) OR ANY OTHER LOSS, COST OR EXPENSE IN CONNECTION WITH THE PRODUCTS REGARDLESS OF WHETHER OR NOT ANY OF THE FOREGOING WERE FORESEEABLE OR THAT SKF WAS ADVISED AS TO THE POSSIBILITY OF SUCH DAMAGES, LOSS, COST, OR EXPENSE.**
- (G) The Limited Lifetime Warranty applies solely to the original Buyer and is non-transferrable.

#### OTHER SKF PRODUCTS

Any SKF product supplied hereunder but not covered by this limited warranty shall be either covered by the applicable SKF limited warranty then in place for such product or, if no such

warranty exists, shall be covered by the 90-day warranty stated above.

#### THIRD PARTY PRODUCT WARRANTIES

For any third party products sold to Buyer by SKF, SKF will transfer to Buyer any warranties made by the applicable third party product vendor to the extent such warranties are transferable.

#### CONDITIONS

As a condition to SKF's warranty obligations hereunder and if requested or authorized in writing by SKF, Buyer shall forward to SKF any Product claimed by Buyer as being defective. Buyer shall prepay all transportation charges to SKF's factory or authorized service center. SKF will bear the cost of shipping any replacement Products to Buyer. Buyer agrees to pay SKF's invoice for the then-current price of any replacement Product furnished to Buyer by SKF, if the Product that was replaced is later determined by SKF to conform to this limited warranty.

SKF shall not be obligated under this limited warranty or otherwise for normal wear and tear or for any Product which, following shipment and any installation by SKF (if required by the contract with the Buyer), has, in SKF's sole judgment, been subjected to accident, abuse, misapplication, improper mounting or remounting, improper lubrication, improper repair or alteration, or maintenance, neglect, excessive operating conditions or for defects caused by or attributable to the Buyer, including without limitation Buyer's failure to comply with any written instructions provided to Buyer by SKF.

SKF shall be free to conduct such tests, investigations and analysis of the Products returned to SKF, as it deems reasonable and proper in the exercise of its sole judgment. As a further condition to SKF's obligations hereunder, Buyer shall offer its reasonable cooperation to SKF in the course of SKF's review of any warranty claim, including, by way of example only, Buyer's providing to SKF any

and all information as to service, operating history, mounting, wiring, or re-lubrication of the Product which is the subject of the Buyer's warranty claim.

**EXCEPT WARRANTY OF TITLE AND FOR THE WARRANTIES EXPRESSLY SET FORTH IN HEREIN, IT IS UNDERSTOOD AND AGREED THAT:**

- (A) SKF MAKES NO OTHER WARRANTY, REPRESENTATION OR INDEMNIFICATION, EITHER EXPRESS OR IMPLIED, INCLUDING WITHOUT LIMITATION ANY IMPLIED WARRANTY OF MERCHANTABILITY, FITNESS FOR A PARTICULAR PURPOSE, OR NON-INFRINGEMENT;**
  
- (B) IN NO EVENT SHALL SKF BE LIABLE OR OBLIGATED FOR SPECIAL, EXEMPLARY, PUNITIVE, INCIDENTAL, DIRECT, INDIRECT, GENERAL OR CONSEQUENTIAL DAMAGES (INCLUDING, BY WAY OF EXAMPLE ONLY, LOST PROFITS OR SAVINGS, LOSS OF BUSINESS OR LOSS OF USE) OR ANY OTHER LOSS, COST OR EXPENSE IN CONNECTION WITH THE PRODUCTS AND RELATED SERVICES, IF ANY, PROVIDED BY SKF, AND THIS DISCLAIMER SHALL EXTEND AS WELL TO ANY LIABILITY FOR NONPERFORMANCE CAUSED BY SKF'S GROSS OR ORDINARY NEGLIGENCE, AND IN ALL CASES REGARDLESS OF WHETHER OR NOT ANY OF THE FOREGOING WERE FORESEEABLE OR THAT SKF WAS ADVISED AS TO THE POSSIBILITY OF SUCH DAMAGES, LOSS, COST, OR EXPENSE; AND**
  
- (C) NO PERSON HAS BEEN AUTHORIZED BY SKF TO MAKE ANY FURTHER OR CONTRARY INDEMNITIES, REPRESENTATIONS OR WARRANTIES ON BEHALF OF SKF. THE FOREGOING LIMITATIONS AND DISCLAIMERS OF LIABILITY SHALL BE MADE APPLICABLE TO THE SALE OF ANY**

**PRODUCT BY SKF TO THE FURTHEST EXTENT PERMITTED BY APPLICABLE LAW.**

The exclusive remedies provided in this limited warranty shall not be deemed to have failed of their essential purpose so long as SKF is willing and able to perform to the extent and in the manner prescribed in this limited warranty.

® SKF, MICROLOG and MULTILOG are registered trademarks of the SKF Group.

CM-F0001 EN  
Revision Y, March 2016

# Index

## C

CPU/IO pair 1-3

## D

Dig1 In Buf Output 1-4, 3-7  
dimensions 7-1

## E

electrostatic discharge (ESD) prevention 2-1  
environmental 7-1

## H

hardware maintenance 4-1

## I

important messages 1-1  
IMx-C unit 1-3  
initiating IMx-C 1-3  
input buffered output 1-4, 3-7  
installation 2-1

## P

power supply unit 1-3

## R

relay 1-4, 3-7

## S

special care 1-1  
storage capacity 1-3

## T

technical data 7-1  
    environmental 7-1  
temperature range 7-1  
troubleshooting guide 6-1

## U

unique features 1-3

## W

weight 7-1