

SKF @ptitude Observer

User Manual Part No. 32170900-EN
Revision Q - January 2019
Observer 11.0

⚠ WARNING! Read this manual before using the product. Failure to follow the instructions and safety precautions in this manual can result in serious injury, damage to the product or incorrect readings. Keep this manual in a safe location for future reference.



SKF Group

® SKF is a registered trademark of the SKF Group.
All other trademarks are the property of their respective owners.

The contents of this publication are the copyright of the publisher and may not be reproduced (even extracts) unless prior written permission is granted. Every care has been taken to ensure the accuracy of the information contained in this publication but no liability can be accepted for any loss or damage whether direct, indirect or consequential arising out of the use of the information contained herein. SKF reserves the right to alter any part of this publication without prior notice.

Patents: US 4,768,380 • US 5,633,811 • US 5,679,900 • US 5,845,230 • US 5,852,351 •
US 5,854,553 • US 5,854,994 • US 5,870,699 • US 5,907,491 • US 5,992,237 • US 6,006,164 •
US 6,124,692 • US 6,138,078 • US 6,199,422 • US 6,202,491 • US 6,275,781 • US 6,301,514 •
US 6,437,692 • US 6,489,884 • US 6,513,386 • US 6,633,822 • US 6,789,025 • US 6,792,360 •
US 7,103,511 • US 7,697,492 • WO/2003/048714

Product Support – Contact Information

Product Support – To request a [Return Authorization](#), [Product Calibration](#) or a [Product Support Plan](#), use the web page links for direct contact and support.

Product Sales - For information on purchasing condition monitoring products, services or customer support, contact your [local SKF sales office](#).

General Product Information

For general product information (i.e., product data sheet, accessories catalog, etc.), visit the [Condition Monitoring Products](#) page on SKF.com and select the appropriate product link.

Technical Support Group

Discuss/review issues of specific interest with maintenance and reliability specialists from around the world at the [SKF Knowledge Centre](#).

For technical support, contact TSG-EMEA@skf.com for customers in Europe, Middle East and Africa.

Telephone +46 (0) 31 337 65 00

or TSG-Americas@skf.com for customers in North America, South America and Asia.

Telephone +1 800 523 7514

Telephone in Latin America +55 11 4448 8620

Product Registration

Please take a moment to register your product at www.skf.com/cm/register to receive exclusive benefits offered only to our registered customers, including receiving technical support, tracking your proof of ownership and staying informed about upgrades and special offers. (Please visit our website for more details on these benefits).

021617dc

Table of Contents

Introduction	1
Data Acquisition Device Support	1-2
@ptitude Observer Logical Architecture	1-3
Communication Possibilities	1-4
Remote Monitoring Possibilities	1-5
Network Connectivity Requirements	1-6
Technical Specification	2
Hardware Connectivity	2-1
Data Processing	2-1
Configuration Features	2-1
Analysis Features	2-2
User Interfaces	2-3
Graphic Displays	2-3
Alarm	2-4
Report	2-5
System Integrity	2-5
Getting Started	3
Database Connection	3-1
Logon	3-1
Change Language Feature	3-2
Switching User Type at Logon	3-2
DASHBOARD	3-3
System Configuration	4
Building a Hierarchy View	4-1
Quick Information	4-2
Database	4-3
Node	4-4
Machine	4-4
Sub Machine	4-6
Measurement Point	4-6
Creating IMx/MasCon Devices and Channels	4-7
Create Device	4-8
Edit	4-23
Delete	4-23
Copy	4-23
Synchronize	4-24
Restart	4-24
Set Time	4-24
Connections	4-24
Measurement Points	4-25

Connect.....	4-26
IP Configuration	4-26
4-20 mA.....	4-26
Firmware	4-27
Command.....	4-28
Analogue Channels.....	4-28
Digital Channels.....	4-32
Machine Properties	4-33
Creating OPC Server and OPC Channels ...	4-40
Internal OPC Server.....	4-41
External OPC Servers.....	4-42
OPC Server Status Tag Value	4-45
Setting up Measurement Points and Alarms	4-46
Measurement Points	4-47
General Tab	4-49
Acquisition Tab	4-53
Operating and Storage Conditions Tab .	4-60
Shaft Properties Tab	4-64
Monitoring Tab	4-65
Adaptive Alarming Tab.....	4-71
Transient Tab	4-72
Observer Display Options Tab.....	4-73
About Multiple Gating Points.....	4-74
Configuring Runout Compensation.....	4-86
Calibrating Shaft Centerline Graph	4-87
Machine Parts.....	4-88
Setting up Process Overview	4-91
Machine Copy Wizard	4-94
Using the Machine Copy Wizard	4-95
Multiple Point Update Wizard	4-98
Using the Multiple Point Update Wizard	4-99

System Operation 5

Startup View	5-1
Tree View	5-1
Hierarchy View.....	5-1
System View	5-10
Workspace	5-11
Diagram View.....	5-12
Graphic Displays and Tools	5-13
Graphic Features	5-13
Graph Settings	5-13
Tools for Graph Display	5-17
Spectra.....	5-20
Full Spectrum.....	5-21
Time Waveform.....	5-23
Phase	5-24
Full Spectrum Phase.....	5-25
History	5-26
Full Spectrum History.....	5-28
3D Plot	5-30
Full Spectrum 3D Plot	5-31
Topology	5-33
Full Spectrum Topology Graph	5-34
Orbit	5-36

Profile	5-37
Gear Inspector	5-38
Trend.....	5-39
Bode.....	5-40
Trend List	5-41
Multi trend	5-42
Diagnosis	5-50
Protean.....	5-53
Polar	5-55
Shaft Centerline	5-56
Combination Plots.....	5-57
Capture (Event and run cycle)	5-61
Buffer	5-71
Notes	5-74
Configuring a Note	5-75
Event Cases	5-76
Editing an Existing Event Case Report..	5-78
Maintenance Planner.....	5-80
Measurement Date	5-81

Menu Items 6

File.....	6-1
Manage Databases.....	6-1
Add External Database	6-3
Remove External Database	6-4
Report	6-4
Log Off	6-6
Exit	6-6
Edit.....	6-7
Multiple Point Update Wizard.....	6-7
Workspace	6-7
Copy Node	6-8
Paste	6-8
Notes.....	6-9
Event Cases.....	6-9
User Preferences	6-9
Properties.....	6-17
Show.....	6-17
Tree View	6-18
Filter	6-18
Hierarchy.....	6-19
System	6-19
Workspace	6-19
Diagram View.....	6-19
Alarm List	6-19
System Alarm.....	6-20
Maintenance Overview	6-20
Message Center.....	6-20
Refresh.....	6-20
DASHBOARD	6-21
Database	6-21
Security Roles	6-21
Users.....	6-26
Database Information.....	6-31
System Log	6-32

Pictures	6-33
Diagnoses	6-34
Libraries	6-41
Export	6-47
Import	6-48
Alarm Group	6-49
Measurement Groups	6-50
Configure a Transient	
Measurement Group	6-54
Configuring an Event Capture Group	6-57
Options	6-68
Delete Data	6-77
Data Miner	6-77
On-line	6-77
IMx/MasCon Devices	6-77
OPC Servers	6-77
Monitor Service Viewer	6-77
Balancing	6-78
Event Log	6-81
Portables	6-83
Microlog Analyzer	6-83
Coded Notes	6-84
Window	6-85
Cascade	6-85
Tile Vertically	6-85
Tile Horizontally	6-85
Close All	6-85
Help	6-85
Contents	6-85
Search	6-85
Enter New License Key	6-85
News in Observer	6-86
SKF Online Repository	6-86
SKF CMC Homepage	6-88
SKF Reliability Forum	6-88
About	6-89

What to Expect When Using Event Capture

	A
Event Capture after an IMx Reboot	A-1
Incomplete Pre and Post Data	A-2
Incomplete Pre Data	A-2
Incomplete Post Data	A-3
Active Range	A-5
Network Interruptions During an	
Event Capture	A-5
Signals Outside Cable Fault	
Detection Thresholds	A-5
Miscellaneous	A-6
Ongoing event capture:	
IMx device restarts	A-6
Manual event capture:	
Alarm event occurs	A-6
Alarm event capture:	
Change in alarm state	A-6

Cancel button	A-7
Alarm leave time	A-7

Summary of Tools in the Toolbar B

Observer Tools	B-1
Primary Toolbar	B-1
Navigation Toolbar	B-2
Measurements Toolbar	B-2
Plots Toolbar	B-3
Graph Display Toolbar	B-4
Plot Tools Toolbar	B-5

Protean Diagnosis C

The Protean Diagnosis system	C-1
Earlier Machine Diagnostics Solution	C-1
The Protean Diagnosis Solution	C-1
Condition Indicator Calculation	C-1
Dynamic Threshold Setting	C-2
Protean diagram example	C-2

SKF Rail Track Monitoring D

Introduction to SKF Rail Track Monitoring	D-1
Licencing	D-1
Terminology used	D-1
IMx requirements	D-2
@ptitude Observer measurement points	D-3
Rail track monitoring configuration	D-3
Rail track monitoring specific icons	D-4
Configuring an IMx-Rail device	D-4
On-line Device Configurator	D-4
Device and channel configuration	D-4
Create Analogue Channels	D-5
Create Digital Channels	D-5
IMx Firmware	D-5
Configuring @ptitude Observer for rail track monitoring	D-5
Introduction to @ptitude Observer configuration	D-5
Trend (rolling) buffer size	D-6
Peak severity settings and storage limitations	D-6
Add Trains	D-8
Create measurement points	D-9
Rail track monitoring configuration	D-14
Viewing captures	D-20
Matching and pattern recognition	D-21
Configuring @ptitude Observer for the Web app	D-22
RailMo tab	D-22
Monitor service tab	D-23
Rail track monitoring security roles	D-24
@ptitude Observer Analysis Tools	D-25
Summary table	D-25
Scatter plot	D-26

Bubble graph.....D-27
Time waveform and spectrum display ...D-28
Event case and Exception workflowsD-28
 Creating an Exception.....D-28
 Exception feedback.....D-33
Using the Web App.....D-34
 Introduction to the Web applicationD-34
 Map of lines.....D-36
 Station dashboard.....D-37
 Processing and closing exceptions.....D-38

End User License Agreement **E**

Index

Introduction

@ptitude Observer is a core platform in a family of reliability software applications that work together as SKF @ptitude Monitoring Suite. It is for data management and analysis of measurement data for condition monitoring, internationally acknowledged for its versatility, performance and user friendliness.

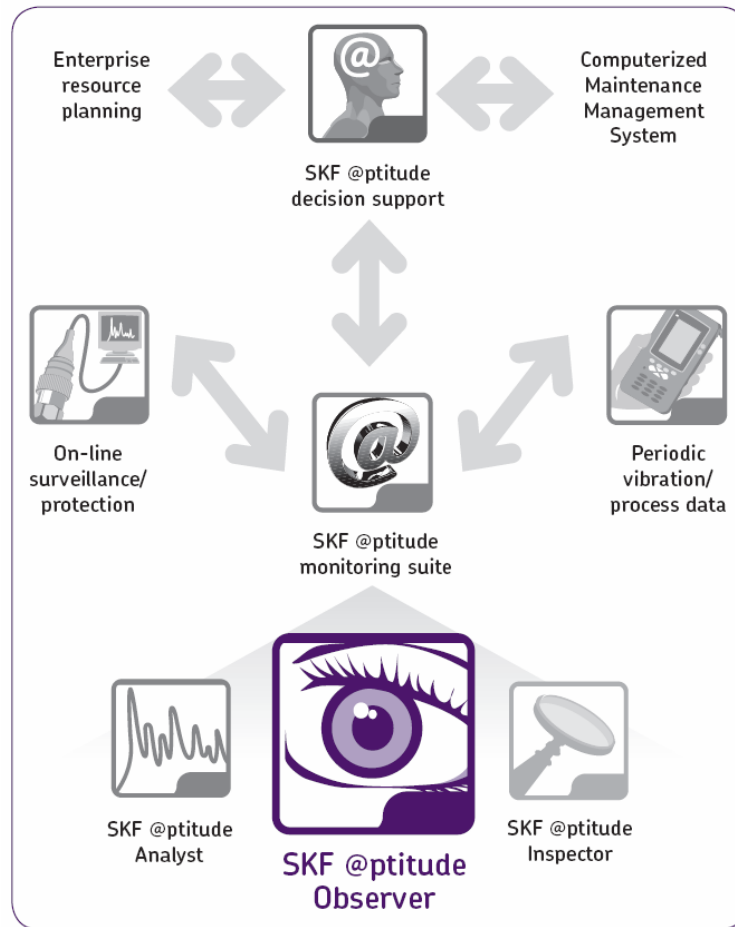

Figure 1 - 1.
SKF @ptitude Monitoring Suite.

@ptitude Observer is Microsoft Windows® -based and supports most of the Windows based systems.

Data Acquisition Device Support

@ptitude Observer supports the following data acquisition devices (DADs):

- MasCon16
- MasCon16R
- MasCon48
- MasCon48P
- IMx-8
- IMx-16Plus
- IMx-Rail
- IMx-B
- IMx-C
- IMx-P
- IMx-R
- IMx-S
- IMx-T
- IMx-W, WindCon
- Microlog CMVA series
- Microlog CMXA 50
- Microlog AX
- Microlog GX
- RB06

Note that the following DADs are not supported by @ptitude Observer 10.5 or 11.0:

- IMx-M

@ptitude Observer Logical Architecture

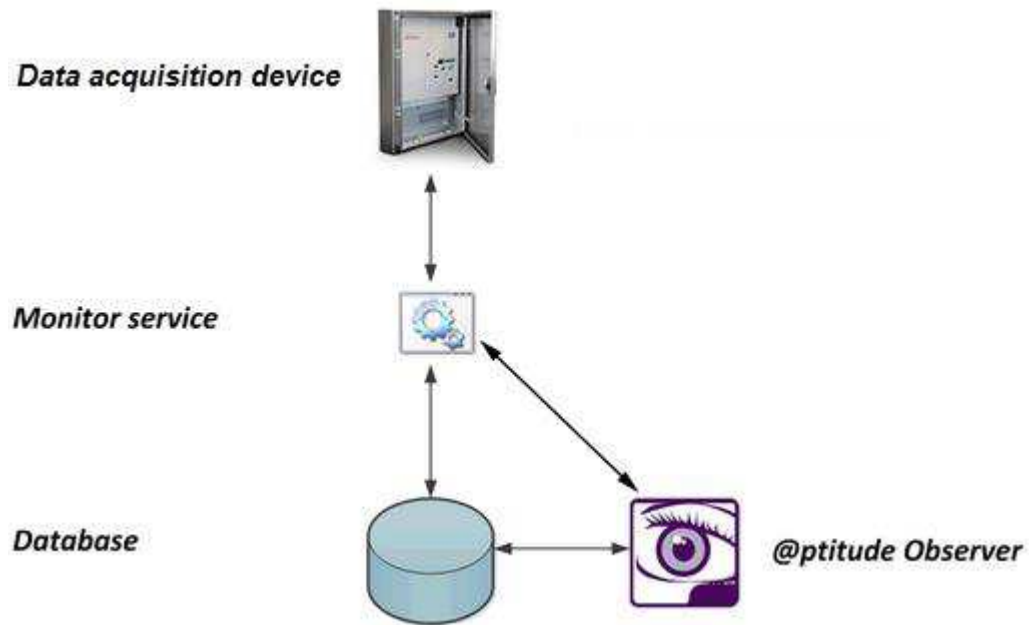

Figure 1 - 2.
SKF @ptitude Observer Logical Architecture.

The operator interface is predominantly based on graphical communication. Operator input like mechanical machine characteristics are also set up graphically and all disturbance frequencies are obtained automatically. The system also has tools for machine diagnostics.

Communication Possibilities

The communication possibilities are almost unlimited. Standard TCP/IP interface allows easily adopted communication through TP cable, fibre optics, two-lead copper wire, wireless LAN, GPRS, ISDN, etc. The system works in a separate network as well as in an existing factory network. The internet can also be a link between IMx/MasCon devices and the @ptitude Observer Monitor as well as between the @ptitude Observer Monitor and @ptitude Observer clients.

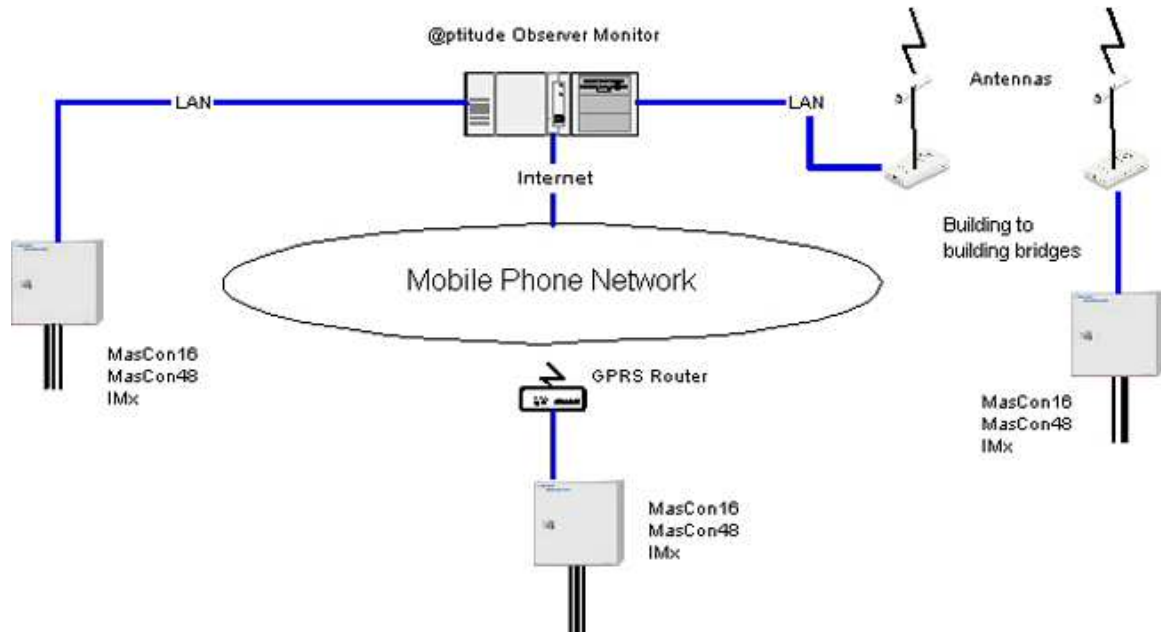

Figure 1 - 3.
SKF @ptitude Observer Communication Possibilities.

Remote Monitoring Possibilities

With @ptitude Observer Monitor and an Internet connection, it is possible to set up @ptitude Observer clients anywhere in the world.

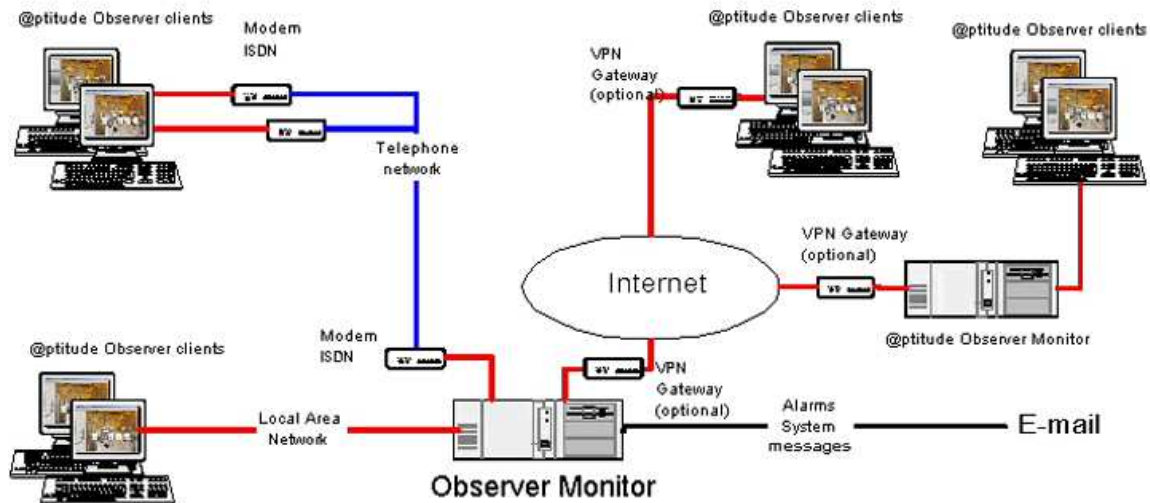

Figure 1 - 4.
SKF @ptitude Observer Remote Monitoring Possibilities.

IMx/MasCon devices are linked to a network which is connected via a modem or LAN to an @ptitude Observer Monitor connected to an SQL database. The @ptitude Observer Monitor can in turn be connected to a LAN network, for example. Several @ptitude Observer clients may be linked to this network. @ptitude Observer can also be installed on the same computer as the @ptitude Observer Monitor service.

Through a general interface such as OPC, it is possible to link the @ptitude Observer Monitor to an existing control or processing system. The @ptitude Observer Monitor, @ptitude Observer clients and the database can be separated physically from each other provided that they are on the same network where ODBC (open database connectivity) calls can travel freely.

Network Connectivity Requirements

- Each IMx/MasCon device needs a TCP/IP compatible communication path to @ptitude Observer Monitor.
- The following connection technologies are some of the examples that can be used:
 - Fibre optics
 - Pair copper wire (<1 Km)
 - ADSL (asymmetric digital subscriber line)
 - DSL (digital subscriber line)
 - Internet
 - 128K ISDN (integrated services digital network) dial-up connection
 - GPRS (general packet radio services)
 - Standard Ethernet network

Important - An on-line condition monitoring system like IMx/MasCon together with @ptitude Observer can be successfully operated only on an installed and tested network infrastructure. Even though the IMx/MasCon devices and @ptitude Observer Monitor are equipped with several fault tolerant routines and procedures, they can ultimately only be as reliable and effective as the network to which they are connected.

2

Technical Specification

Hardware Connectivity

IMx is a series of on-line monitoring systems with dynamic/static inputs, digital inputs and digital outputs with simultaneous measurement on all channels up to 40 kHz. The available number of inputs, outputs and the physical form varies depending on the type of the data acquisition device.

MasCon16 is an on-line monitoring system with 16 dynamic/static inputs, 2 digital inputs, 4 digital outputs.

MasCon48 is an on-line monitoring system with 48 channels and 4 configurable interface cards, also available as a portable device.

SKF Microlog Analyzer is a portable data collector for single or multi-channel measurements.

Data Processing

- On-line data acquisition from IMx/MasCon (Ethernet, TCP/IP).
- On-line process data through OPC (object linking and embedding for process control).

Configuration Features

- **Hardware interface settings** for each IMx/MasCon device are configured by means of alarm hysteresis and types of interface cards. Each channel of the hardware is configured by the type of signal, gain, BIAS voltage limits and correction factors for run-out and linearity.
- **Measurement points.** The following are the measurement point types that can be configured.

Dynamic based measurement points

- Dynamic
- Dynamic, AEE
- Dynamic, Envelope
- Dynamic, Process
- Harmonic
- SEE® (spectral emitted energy)
- Time Waveform Analysis
- Time Waveform Analysis, AEE

Trend based measurement points

- Counter
- Counter rate

- Data tagging
- Derived
- Derived point
- Digital
- Gear inspector
- HFD (High Frequency Domain)
- OPC (Object linking and embedding for Process Control)
- Process
- Running hours
- Shaft centerline
- Speed
- Speed from spectra
- Time difference
- Torsion

Analysis Features

FFT (Fast Fourier Transform) analysis is the classic way of analysing vibration data where the vibration signal is shown as a function of frequency. Frequency ranges from 0 to 10 Hz up to 0 to 40 kHz and resolutions from 100 to 6 400 lines can be used.

DPE (Digital Peak Enveloping) analysis is an excellent method to detect small impulses such as bearing defect in a noisy environment.

Bearing database stores geometrical data from approximately 30 000 different bearings from several different manufacturers. It is used for automatic defect frequency calculation.

Machine diagnostics expert system uses a rule based diagnostic system for automatic frequency analysis which gives clear text messages regarding fault type.

Graphic tool for machine data setup is used to define all mechanical data for defect frequency calculation as well as machine diagnostics. The whole drive chain is set up graphically by using drag and drop from a machine component toolbox.

Run-up/Coast down occurs when a machine is started or stopped. At such occurrences the system can be configured to store transient data according to the user defined conditions, like speed variations, set for the actual measurement group. During transients, separate alarm conditions can be applied.

Time waveform analysis is a smart detection of time waveform signature patterns to identify or prevent problems that might not be detected by FFT analysis. The algorithms included are crest factor, kurtosis and skewness. Advanced analysis can be performed with the event capture capability that has continuous pre-and post-event, data capture. The captured time waveforms enable detailed analysis of both very low frequency (mechanical) and very high frequency (electrical or generator related) oscillations.

Balancing is the on-line balancing of machines especially designed for turbines with 15 planes and 5 states with a maximum of 40 measurement points simultaneously.

Order tracking analysis is an efficient way to analyse machines with variable speed. Order tracking analyses the speed measured on each shaft revolution as a means of adjusting the number of samples taken for that revolution. This process keeps the number of samples per revolution identical regardless of shaft speed.

User Interfaces

Hierarchy View shows machines and their measurement points in a tree structured hierarchy with corresponding status for each object. The hierarchy can display data from several databases at the same time.

System view shows the status from a hardware point of view which is based on IMx/MasCon devices, sensors and measurement points. It also shows communication status.

Workspace is a hierarchy view of user selected machine(s). It is an individual work space to keep track of only the machines for which the user is responsible. A workspace can span only one single database.

Diagram view saves all the settings of a graphic diagram including selection of measurement points as well as buffer settings. This is to be able to have predefined views of the data.

Graphic Displays

Any graphic display can be set in live mode and be updated whenever possible. The update rate is determined by the setup and time involved in capturing the actual data.

- **Spectra** shows the vibration amplitude as a function of frequency.
- **Time waveform** shows the vibration signal as a function of time and offers the possibility to listen to the signal if a sound card has been installed in the computer.
- **Phase** displays the binary representation of phase data for the time waveform from -180 to 180 degrees.
- **History** displays historical data in a combined plot for spectra, time waveform and phase.
- **3D Plot** illustrates vibration spectra or envelopes as a function of time, shaft speed, power, temperature, torque or any other DC parameter.
- **Topology** illustrates frequency spectra versus speed or time by using colour separation.
- **Orbit** displays the shaft orbital movement by using signals from two perpendicularly mounted transducers.
- **Profile** uses triggered acceleration time signal data to represent an un-roundness of any circular object.
- **Gear inspector** is used to visualize the impact energy as a function of shaft/gear revolutions.
- **Trend** shows vibration amplitude/phase or process data as a function of time, speed or other process data.

- [Bode plot](#) shows any type of data such as vibration amplitude/phase or process data as a function of speed.
- [Trend list](#) shows vibration amplitude/phase or process data as a function of time, speed or other process data as Trend but in a list.
- [Multi trend](#) overlays data from several measurement sources in a combined trend and bar graph. It is also possible to view data as a function of any of the other selected points.
- [Diagnosis](#) shows the built-in prognostic and historic fault detection algorithm calculations.
- [Protean](#) shows the automatic prognostic graphs with machine health indicators.
- [Polar](#) shows the vibration signal at 1, 2, 3 and 4 times the shaft speed in the complex domain.
- [Shaft centerline](#) displays shaft movement inside a bearing.
- [Combination plots](#) facilitates the analysis by combining displays into one graph showing related data.
- [Capture](#) is a time waveform (of user defined length) that can be used for capturing data, 'pre and post' a specified event.

[SKF Rail Track Monitoring](#) has its own special displays to aid the analysis of track condition. These are based on data from IMx-Rail devices that has been matched to specific rail sections before being processed.

Alarm

There are a variety of alarm features such as level alarm, trend alarm, vector alarm, diagnostics alarm and circle alarm. Upon alarm, notifications can be automatically sent to designated user(s) by e-mail or SMS (short message service).

- **Speed dependent alarm conditions** can be up to 15 primary alarms for each measurement point. These alarms can be at a fixed frequency, fixed frequency range, speed dependent frequency or speed dependent frequency range.
- **Speed or load dependent alarm level** can be fixed or set as a function of shaft speed or any DC measurement point for each alarm level. For each alarm condition, there are two alarm levels for vibration measurement points and four alarm levels for DC measurement points.
- **Class dependent alarms** (for Dynamic and Dynamic Envelope points only) can be enabled as alarms dependent on the two Multiple Gating Point operating classes. This disables other alarms. Refer to [Enable class dependent alarms](#) for details.
- **Alarm group** can be created if a user wishes to collect data from other measurement points. When an alarm is raised the measurement data at that measurement point is saved in the database. If one of the measurement points in the alarm group generates an alarm, data on all the measurement points in that alarm group will be saved.

Report

PDF-based and Word reports containing alarm lists, notes, manual conclusions, trend data, diagnosis reports and condition monitoring statistics can be produced by the Report Wizard.

System Integrity

- System alarms via e-mail or SMS messages.
- User defined system privileges and preferences for each individual user.
- Database management tool for database backup and database replication.
- Automatic hardware serial number verification.
- Error logs.
- Tracking of TCP/IP communication package errors.
- Hardware sequence number tracking.
- Missing data alarm

Getting Started

To start @ptitude Observer, first select a language at "Select language" screen.

If this copy of @ptitude Observer has not yet been registered, the "Unregistered version of Observer" screen will appear, for the necessary action to be taken.

Clicking the **Enter license key** button the **License Key** screen appears for the license key to be entered. Alternatively, the session can be continued by clicking the **Continue unregistered** button. However, there will be further prompts from time to time throughout the session until the product is registered.

Note that once a language has been selected and the license key entered, this user will not be required to enter them again and @ptitude Observer will directly prompt the user to select a database to be connected.

Database Connection

To run @ptitude Observer, a database must be connected. Refer to [Manage Databases](#) under File in Menu Items section.

Logon



Figure 3 - 1.
Observer Logon.

A default user (User name/Password: "admin"/"admin") can be used to start the system. However, it is strongly recommended to create individual user accounts for those who have the access to the system. It is necessary to have individual user accounts and rights, so that configuration changes can be tracked.

The system will remember the user name and the password if the **Remember me** checkbox is marked.

Change Language Feature

There is the option to change the language of the application before it starts. After entering **User name** and **Password**, select the desired language from the **Language** list and then click **OK**. The Observer application will initialize in the selected language.

- The language can be changed only upon starting up. When ending a session or logging off without exiting, the **Language** list is disabled.

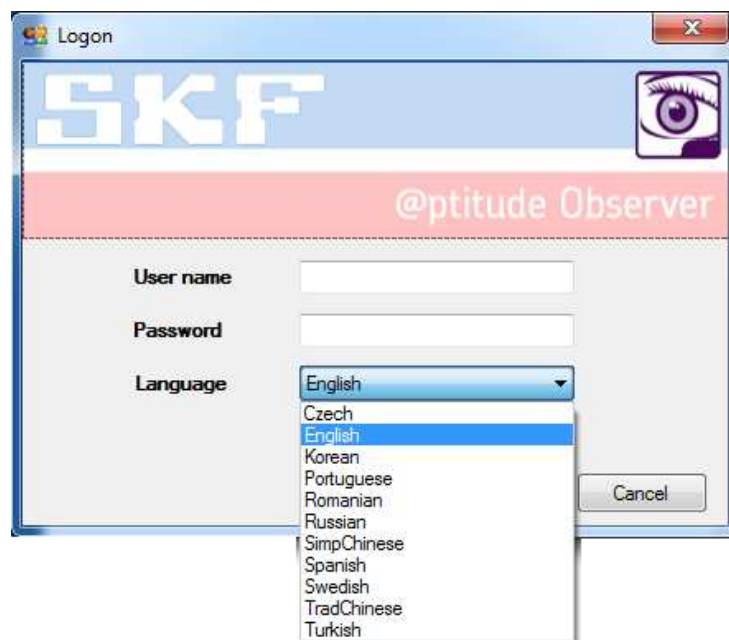

Figure 3 - 2.
Language Selection Capability.

Switching User Type at Logon

Users with 'Machine Operator Level 1' security role can switch user type without exiting the application: for example, if logged on in this role and then there is a need to make a change requiring administrator privileges.

To do this, log out as usual by going to **File > Logout**. Or, from the Process overview workspace, right-click and select **Log off** from the menu. There will be a prompt to confirm the log off. Click **Yes**.



Figure 3 - 3.
Log off confirmation.

Once logged off, the **Logon** dialog opens automatically. Log on as a different type of user, such as Admin, to perform the required tasks.

DASHBOARD

After a successful logon, the "DASHBOARD" screen will provide Notifications, News Feed and Message Center interfaces.

Refer to [Dashboard](#) under Show in Menu Items section.

System Configuration

This chapter describes the configuration of @ptitude Observer, how to get the analysis work started quickly and how @ptitude Observer works as a condition monitoring system.

The configuration of @ptitude Observer is usually performed when the system is installed, however changes can be easily made.

Prior to analysing measurement data, @ptitude Observer must be configured for the particular plant and its machinery. It is important that all machine parts as well as measurement points are located at the correct positions.

Guidance for System Installations

Regular backup of the database is normal practice. Backup intervals and methods are governed by the specific needs of each installation. It is a best practice to create a full backup before any major upgrade of @ptitude Observer.

Databases with many attached IMx devices will grow rapidly. For a new database, it is advised to initially utilise less than 75% of the maximum capacity to allow for future expansion.

Experience shows that grouping devices by customer or by wind farm leads to databases with less IMx systems.

Recommended System Configurations

To get a system up and running properly the following system configurations should be covered.

- [Build a hierarchy view](#) by creating necessary plants, areas and machines to organise the condition monitoring systems.
- [Define hardware devices](#) such as input boards, sensors, signal characteristics, etc. for each device and channel.
- [Define machine parts](#) by defining the drive line for each machine. All shafts, bearings, gear wheels, drive belts, impellers along with other machine parts, are connected to a drive line. Based on these inputs the system can calculate all defect frequencies within the whole machine.
- [Set up measurement points and alarms](#) to get the data into the system. For on-line systems, multiple measurement points can be defined per channel, if needed.
- [Build a process overview](#) for an on-line condition monitoring system which can support viewing data, live as it comes into the system. IMx/MasCon devices typically measure and send data faster than other on-line data acquisition devices. @ptitude Observer enables the creation of user defined displays with measurement points and links to other displays overlaid on graphic pictures like drawings, digital photos, etc.

Building a Hierarchy View

The idea behind the hierarchy view is to achieve a logical grouping of all the measurements and their positions related to one another.

The hierarchy view consists of the following attributes:

- [Database](#)
- [Node](#)
- [Machine](#)
- [Sub machine](#)
- [Meas. point](#)

Event capture groups also display in the hierarchy view. The event capture group supports time waveform points for pre-and post-event, data capture. Each IMx unit can have only one event capture group, which will display before other points in the machine's hierarchy. Event capture measurement points display as children of the event capture group. Refer to [Measurement Groups](#) for information about the creation and configuration of event capture groups.

Quick Information

At any time, it is possible to hover the mouse over any item in the hierarchy view tree to display additional information about the node, machine, sub-machine or measurement point. In addition to some basic information, the latching status of the node is shown, as well as the status of the last reading. (The latching status is the summarized status which is shown in the hierarchy.)

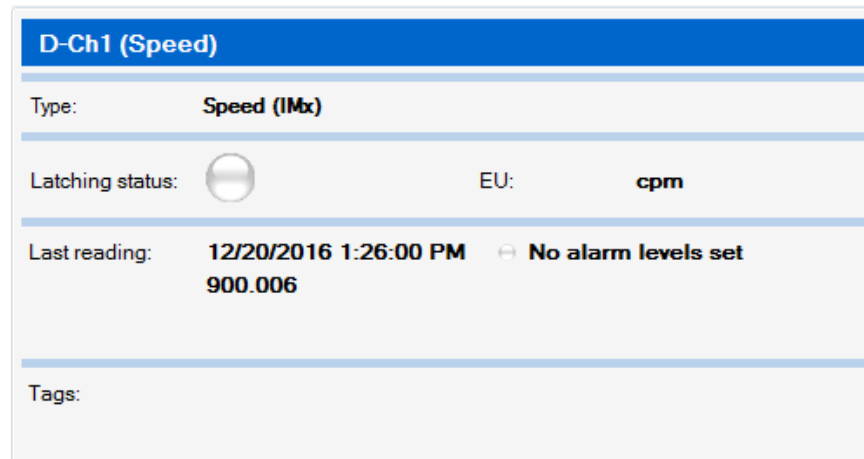

Figure 4 - 1.
Example of Quick Information on Mouse Over.

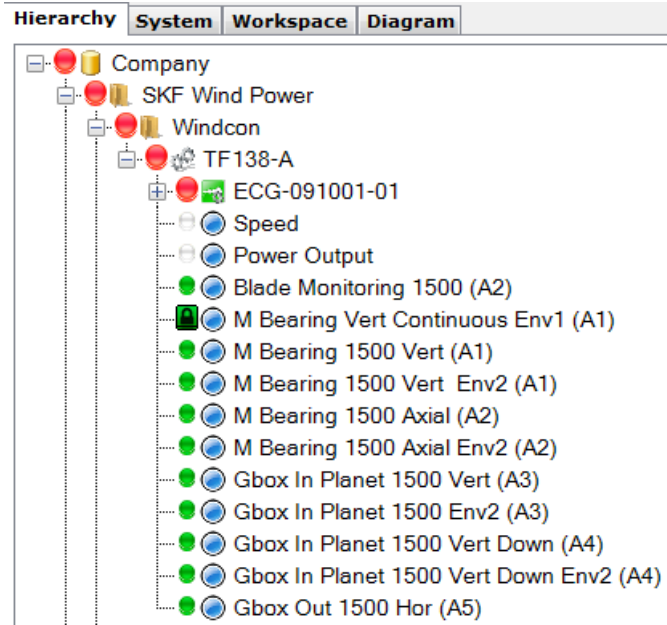

Figure 4 - 2.
Example of the Hierarchy View.

Database

Database is the logical top level of the hierarchy view with nodes, machines, sub machines, measurement points, machine parts and machine properties underneath.

The main database gets added to the hierarchy view as a top level when a database is selected from the list of registered database connection on local computer via Connections interface under [Manage databases](#) in File menu item.

External databases can be added to the hierarchy view as a top level via [Add external database](#) interface in File menu item.

Node

Node is a logical grouping of machines which can be a top node or located within any other nodes. The number and level of nodes are unlimited.

To create a Node:

- First select a node or a database in which a node is to be added in the hierarchy view.
- Click on the right mouse button, select **Add**, then **Node**.
- On the properties screen, enter the name of the node and its description.

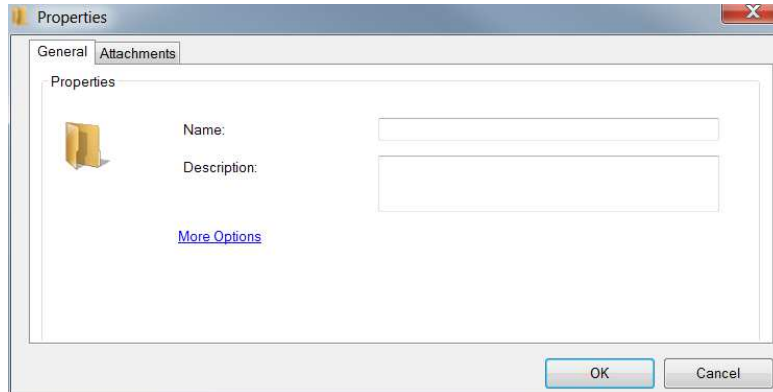

Figure 4 - 3.
Create a Node.

Machine

Machine is located in a particular node, for example, Fan 2, Pump 3a, etc.

To create a Machine:

There are different ways to create a machine.

1. First select a node or a database in which a machine is to be added.
2. Click on the right mouse button, select **Add**, then **Machine**.

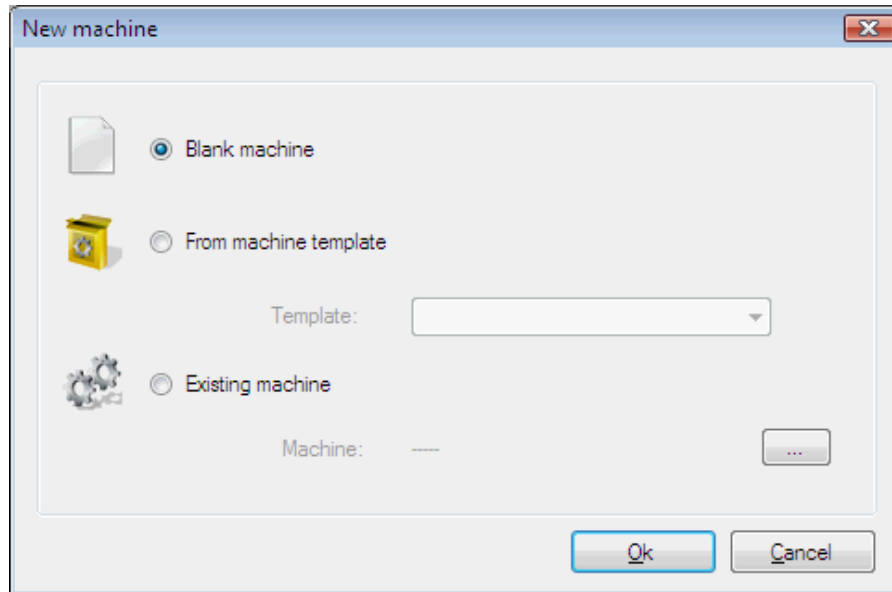

Figure 4 - 4.
Create a Machine.

- Creating a machine from scratch.
 - Select **Blank machine**, then click **Ok**.
 - Enter the machine properties in General and Extended Information screens. Refer to Machine Properties under Creating IMx/MasCon Devices and Channels in System Configuration.
- Creating a machine from a template.
 - Select **From machine template**.
 - Choose a **Template** from the drop-down list.
 - Click **Ok** to launch the Machine Copy Wizard to help with the process of copying a machine to a new location. Refer to [Machine Copy Wizard](#) in System Configuration.
- Creating a machine by copying an existing machine.
 - Select **Existing machine**.
 - Click the ellipses button and then select a machine from the displayed hierarchy view.
 - Follow the instructions in the [Machine Copy Wizard](#) section in System Configuration.

Sub Machine

A sub machine is a sub section of a machine.

To create a sub machine:

- First, select a machine in which a sub machine is to be added in the hierarchy view.
- Click on the right mouse button, select **Add**, then **Sub machine**.

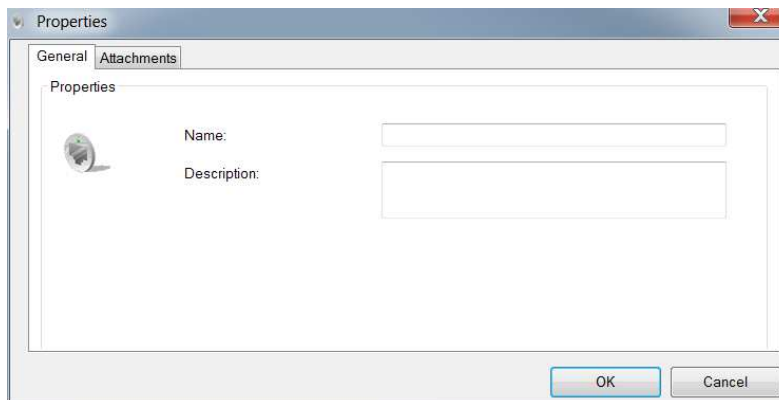

Figure 4 - 5.
Create a Sub Machine.

- On the properties screen, enter the name of the sub machine and its description.

Measurement Point

Measurement point is a measurement that should be captured on a machine. Here a type of sensor, position of sensor, resolution, frequency range, etc. are specified.

Creating Measurement Points

Refer to [Setting up Measurement Points and Alarms](#) in System Configuration.

Creating IMx/MasCon Devices and Channels

This section shows how to set up and edit IMx/MasCon devices and their corresponding channel layouts for the selected database.

Channels must be initiated before they can be assigned with measurement points.

The number of channels is dependent of the device type.

- Each WindCon or MasCon16 device has 16 channels of the vibration/analogue type and 2 channels of the speed/digital type.
- An IMx device typically has 8 or 16 dynamic/analogue channels and 2, 4 or 8 digital channels (dependent on the specific IMx device).
- Each fully equipped MasCon48 device has 32 channels of the vibration/analogue type and 16 channels of the speed/digital type.

To get to IMx/MasCon devices screen:

- First, click **On-line** on the toolbar.
- Select **IMx/MasCon devices**.

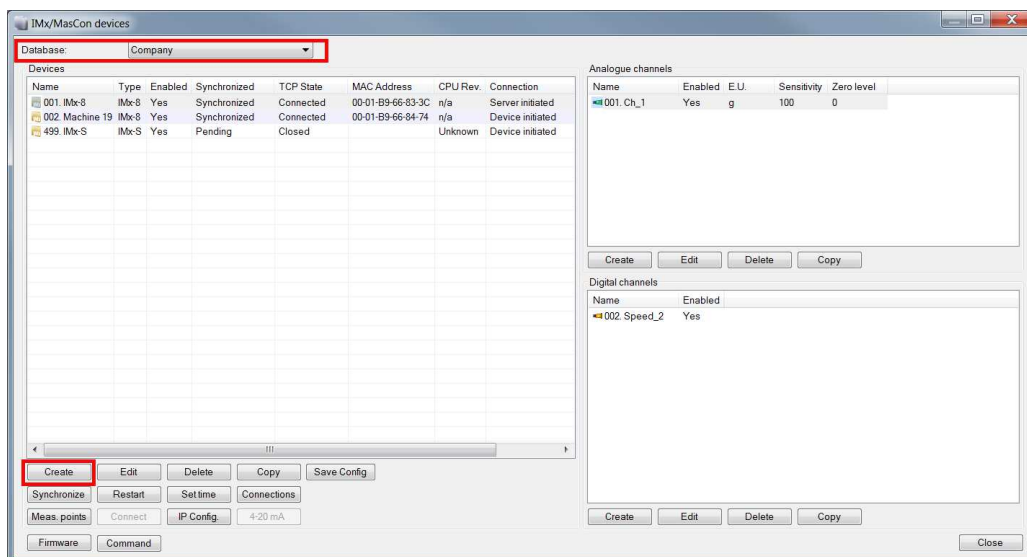

Figure 4 - 6.
Example of IMx/MasCon Devices Screen.

- Select a database.

Create Device

Click the **Create** button below the **Devices** table to create a new device for the selected database. On the **New device** dialog, select the **Type** of device to be created. A screen for creating the new device appears.

slave name	slave address	IP Address	Port	Byte order
Slave 1	33		0	Big endian
	0		0	Big endian
	0		0	Big endian
	0		0	Big endian

Figure 4 - 7.
Example of Create IMx Screen.

The following attributes are available for creating a device. Note that different attributes are available depending on the device **Model** selected.

Number is a unique number for the device. IMx devices may have a unit ID number from 1 to 9 999. Mascon16 and Mascon48 devices may have a device ID from 1 to 255.

Name is a free text name that can be used to identify the device.

Model is the type of device, for example: IMx-8.

Enabled indicates the status of the device; whether it is enabled (if checked) or disabled.

Serial no. (available for IMx/MasCon16 only) displays the serial number that this device should have. This is to enforce data integrity.

When a device is set up it will get the serial number "0".

When a device connects for the first time, the serial number of that device will be stored automatically in the database.

The next time any device connects with the specific device number the device is challenged for a serial number match. If serial numbers mismatch the device is not allowed to connect to the monitor service and a system alarm will be generated to the user.

If the device is replaced or the CPU board of the device is replaced, it is necessary that the serial number is reset by clicking the reset button.

MAC Address displays the MAC address of the unit stored in Observer. With firmware v5.907 or later, the MAC address, IMx model and memory size of the device are detected automatically when the device connects to Monitor and Observer.

- The MAC address and memory size (CPU Rev) will be stored in Observer if it does not already exist. The CPU Rev is stored as “Higher than v1.48” if the SDRAM-size is 64 MB and “Lower than v1.48” if the SDRAM-size is 32 MB. When Monitor generates a configuration, it checks if the configuration needs the newer “Higher than v1.48” CPU type. If there is a mismatch; a system alarm will be sent to Observer informing the user of this and a popup with the text “Invalid Device Configuration” will be displayed in Observer.

When an IMx device connects to Monitor and Observer, Monitor compares its MAC address and model to what is configured in Observer. If there is a mismatch, a system alarm in Observer informs the user. The alarm contains the MAC address or Model that the device sent. The connection is closed when there is mismatch of the MAC address or Model.

Clear – click the **Clear** button to clear both the stored serial number and the MAC address of the unit in Observer. The **Clear** button also clears any association with any device that has been assigned through the **Set detected device** function.

Set detected device – click the button to choose from a list of all the devices detected on the network that are available for replacement (assignment to the specific unit). Selecting another device from the drop-down list will remove other existing associations, if any, with a current device. **Set detected device** is a way to “transfer” the identity of a detected device to an already configured device that exists in Observer or to create a new device in the Observer database based on the detected device.

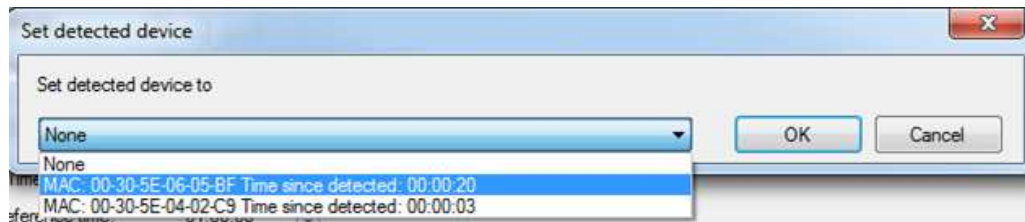

Figure 4 - 8.
Example of Set Detected Device List.

The drop-down list contains only devices that meet all the following criteria:

- are detected in the last two hours
- are in stand-alone mode
- are not already assigned to a device
- are not in maintenance mode

If “transferred”, the IMx Model must be the same on the existing device and the detected device. After the configuration is done, it will always be Monitor that initiates the transfer process, not the IMx.

The **Connection** column on the IMx/MasCon devices screen indicates whether the connection to the device is Device initiated (the default) or Server initiated (initiated by Monitor).

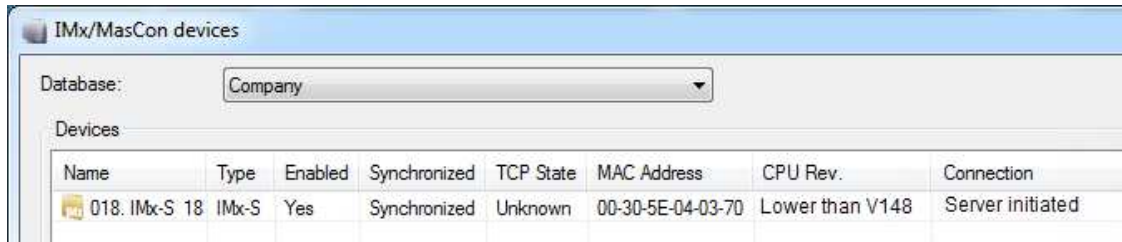

Name	Type	Enabled	Synchronized	TCP State	MAC Address	CPU Rev.	Connection
018. IMx-S 18	IMx-S	Yes	Synchronized	Unknown	00-30-5E-04-03-70	Lower than V148	Server initiated

Figure 4 - 9.
Example of the **Connection** Column.

Reference time is a parameter that can be used to spread the workload in the @ptitude Observer environment by setting the execution time of daily-based work.

Timeout comm. (communication) is an interval of time in minutes used to generate a system alarm if there was no communication between the device and the @ptitude Observer Monitor for that interval of time.

Connection interval is an interval of time in hours when a connection should be established between an IMx/MasCon16 device and @ptitude Observer Monitor. It is used, for example when using ISDN (integrated services digital network) routers.

External communication is available for IMx (and to a more limited extent, MasCon16) devices. It is used to configure the functionality of the selected external communication type on the device.

Type can be None, Modbus, GPS(GPS50M), MVB, TSI or IEC61850 MMS. Note that the available types vary depending on the model of the selected device.

- Modbus, supports connections between the IMx and multiple other Modbus devices including the possibility of simultaneous RTU and TCP, master and slave usage. See [Modbus Communication](#) and following sub-sections for typical scenarios and the restrictions that apply.
- GPS(GPS50M), implements a fixed Modbus RTU Master configuration for communication with the SKF supplied GPS receiver module. Note that selecting this option implements a dedicated Modbus configuration to import that data, which does not support other or multiple devices, see [Configuring External Channels](#).

For Modbus: **(Master) Mode** can be set as either TCP Master or RTU Master.

For Modbus RTU:

Bps defines the speed of the Modbus bus.

Parity provides Modbus data validation which can be set to No Parity, Odd Parity or Even Parity.

Stop bits defines the number of stop bits in use for Modbus. It can be 1 or 2.

Slave Name is a name given to help identify the Modbus slave device.

Slave Address is a Modbus slave address with which the (IMx) Modbus master communicates.

IP address specifies the IP address of the desired target device.

Port is the standard port for the Modbus TCP/IP protocol.

Byte order specifies the byte arrangement of the slave data being read.

Data Import accesses [Configuring External Channels](#)

Slave: TCP and/or RTU support

Slave address here, is the address of this IMx, as a slave device.

Bps, Parity and Stop bits, for the Modbus RTU link (when used)

Max number of masters is the number of external Modbus TCP master devices which will access this IMx.

Value type is either Integer 16 bit or Float 32 bits.

Data export accesses [Configuring Modbus Export](#)

Parameter is application specific and is required only for MVB and TSI types.

Interface card is a hardware configuration card which is required for MasCon48 only. Four different cards can be selected and each card has 8 channels.

AC/DC 25 V: for analogue inputs, for example when a device is equipped with eddy current probe systems.

AC/DC 15 V: for analogue inputs, for example when a device is equipped with accelerometers.

DC: for a device with temperature and pressure sensors.

DC Isol (isolated): for a device with an external signal such as an input motor load.

Time server (NTP server) configures the Time server (NTP server) for an IMx device. NTP stands for Network Time Protocol, which is an Internet protocol used to synchronize computer clocks to a specified time service. (See Figure 4-7.)

Same as monitor server (default) uses the NTP Server parameters specified in the network configuration file downloaded through the serial interface. See [time synchronization thresholds](#) for details about setting up threshold alarms.

Same as IEC Server If this option is selected, the IEC server to be used, must be identified. In the External communication section, select the **Type** as **IEC61850 MMS**. Next, check **Client Enabled**. Enter the **Server address**, which is the IP address of the IEC Server.

Use IP address enables the IMx device's NTP IP address to use the same NTP service as the machines (turbines etc.) it is monitoring.

For example, IMx A is monitoring Machine 1. Machine 1 is an NTP client of an external NTP service. By setting the NTP server address of IMx A to point to the same NTP service as Machine 1, the timestamps from Machine 1 and IMx A will be aligned. See [time synchronization thresholds](#) for details about setting up threshold alarms.

System log is a record containing all the historical configuration changes made to the device.

Edit TSI Config is available for IMx-R devices only. It configures the IMx-R TSI part and MVB. For more information, refer to the "IMx-R User Manual."

Modbus Communication

Subject to certain restrictions, an IMx supports multiple Modbus instances (Table 4-1), including simultaneous RTU and TCP use and support for multiple slave devices.

Table 4-1.
Allowable Modbus combinations.

	TCP Master	RTU Master
TCP Slave	Supported	Supported
RTU Slave	Supported	Not supported
TCP Slave + RTU Slave	Supported	Not supported

Only one instance can use **Master Mode**:

- If RTU Master is selected then RTU Slave is unavailable
- If TCP Master or None is selected the IMx can be a TCP and/or an RTU slave

The IMx can be a **TCP** or **RTU Master** to multiple slave devices and a **TCP** slave to multiple masters:

- The total number of Modbus connections is limited to 4
 - 'Modbus Connections' is the sum of all slaves (to which the IMx is a master) and masters to which the IMx is a slave (TCP and RTU).

GPS(GPS50M) represents a special Modbus configuration where the IMx is an RTU master to a single specific (GPS receiver) module, with slave address, 1. In that case no multi-use of the Modbus RTU communications is allowed.

The examples in the following sections will illustrate typical usage.

Configuring Modbus Master Communication

When **Type** Modbus is selected and the **Mode** is RTU Master, the **Bps**, **Parity** and **Stop bits** fields are available. Select the same serial port parameters (Bps, Parity, Stop bits) as for the generic Modbus slave to ensure communication between master and slave.

External communication

Type:

Master

Mode:

Bps: Parity: Stop bits:

slave name	slave address	IP Address	Port	Byte order
Slave 1	33		0	<input type="text" value="Big endian"/>
	0		0	<input type="text" value="Big endian"/>
	0		0	<input type="text" value="Big endian"/>
	0		0	<input type="text" value="Big endian"/>

Figure 4 - 10.
 Example of IMx with Modbus Communication Mode RTU Master.

When **Type** Modbus is selected and the **Mode** is TCP Master, the **TCP/IP address** and **Port** fields are available. Enter the **TCP/IP address** of the desired target device. **Port** number is always set to 502.

External communication

Type:

Master

Mode:

slave name	slave address	IP Address	Port	Byte order
Slave 1	33	10.0.0.33	502	<input type="text" value="Big endian"/>
	0		502	<input type="text" value="Big endian"/>
	0		502	<input type="text" value="Big endian"/>
	0		502	<input type="text" value="Big endian"/>

Figure 4 - 11.
 Example of IMx with Modbus Communication Mode TCP Master.

Master devices retrieve data from slave devices (and in the IMx this data is written to 32 virtual channels, see [Configuring External Channels](#)). The Modbus **Byte order** setting is a per slave setting that specifies how the slave data is organised and how to read the bytes in the client unit (IMx).

Big endian format stores the most significant byte first at the lowest storage address.

Big endian word swap takes the big endian format and swaps the word order of two consecutive registers.

Little endian format stores the least significant byte first.

Little endian word swap takes the little endian format and swaps the word order of two consecutive registers.

- Since the required word swap depends on the size of the numbers stored in the file (two 2-byte integers require a different swap than one 4-byte integer), the file format must be known to perform endianness conversion.

For more information, refer to the application note: "General Modbus Protocol Considerations for IMx Devices" (document part number CM3226).

Up to four slaves can be associated with the IMx master and a table row is available for specific settings for each. The available rows (maximum number of slave devices supported) in any particular situation is affected (reduced) by the number of instances where the IMx is also configured as a slave to a Modbus master.

A right click context menu provides for removing a slave entry and for copying slave settings to an empty/available table row:

slave name	slave address	IP Address	Port	Byte order
Slave 1	21	10.0.0.33	502	Big endian
			502	Big endian
			502	Big endian
	0		502	Big endian

Figure 4 - 12.
Context menu for copying and deleting slave devices.

Note that all slaves should have unique **Slave Address** entries.

Warning messages will be given under the following circumstances:

- Attempting to select RTU Master when RTU slave mode is already enabled
 - Not allowed
- Changing the **Mode** from TCP Master to RTU Master
 - Allowed, but results in loss of TCP configuration information

Configuring Modbus Slave Communication

Subject to the choice of master mode and the number of slaves which should be addressed, there is also the possibility to configure the IMx as a slave device:

Parameter	TCP	RTU
Mode	<input checked="" type="checkbox"/>	<input checked="" type="checkbox"/>
slave address	1	1
Port	502	
Max number of masters	1	
Bps		19200
Parity		None
Stop bits		1
Value type	Integer 16 bit	
Data Export	Data Export	

Figure 4 - 13.
Example of IMx configured as Modbus Slave.

A slave device typically makes data available to external Modbus master devices, see [Configuring Modbus Export](#).

Slave devices can usually also import data, [Configuring External Channels](#), but this is not allowed if, in another Modbus instance, the IMx is also a Modbus master.

When RTU is selected, the **Slave address**, **Bps**, **Parity** and **Stop bits** fields are available. Select the same serial port parameters (Bps, Parity, Stop bits) as for the generic Modbus master to ensure communication between master and slave.

When TCP is selected the **Port** number is read only and only the **Slave address** and **Max number of masters** fields are available.

Max number of masters: The IMx can be a TCP slave to multiple Modbus master devices. Set here the maximum number of master devices to accept, noting that the range is 1 to 4*

*4 is only allowed where no other Modbus connections are in use. Each connection (as a TCP or RTU Modbus slave to one master device and as a TCP or RTU Master to one slave device), counts towards the total allowance of 4 connections.

The **Value type** selection and **Modbus export** button configure up to 128 registers of measurement data, for export to a Modbus master. This data and its configuration is common to all connections to external master devices (they all have the same data available to them).

The **Value type** setting specifies how the IMx presents the values, either as Integer 16 bit or Float 32 bit. When Float 32 bit is selected, the following apply:

- Only odd register numbers are used in the **Modbus export** dialog.
- A maximum of four speed channels are allowed, depending on the IMx model.

Configuring Modbus Export

Click the **Data export** button to open the Modbus Export dialog.

The configuration window assigns a measurement point to a Modbus input register. A multi-channel point uses one Modbus register for each channel.

- All IMx point types are supported except Running hours, Counter and Gear inspector measurement points.

Note that the population of the Modbus export dialog after a database upgrade will have the following exclusions:

- Multi-channel measurement points are excluded from the Modbus export dialog. To export the measurements, select the points again from the **Point name** drop-down list.
- In measurement points with decimals in the measurement range the **Full Scale** is rounded up to the greater integer.

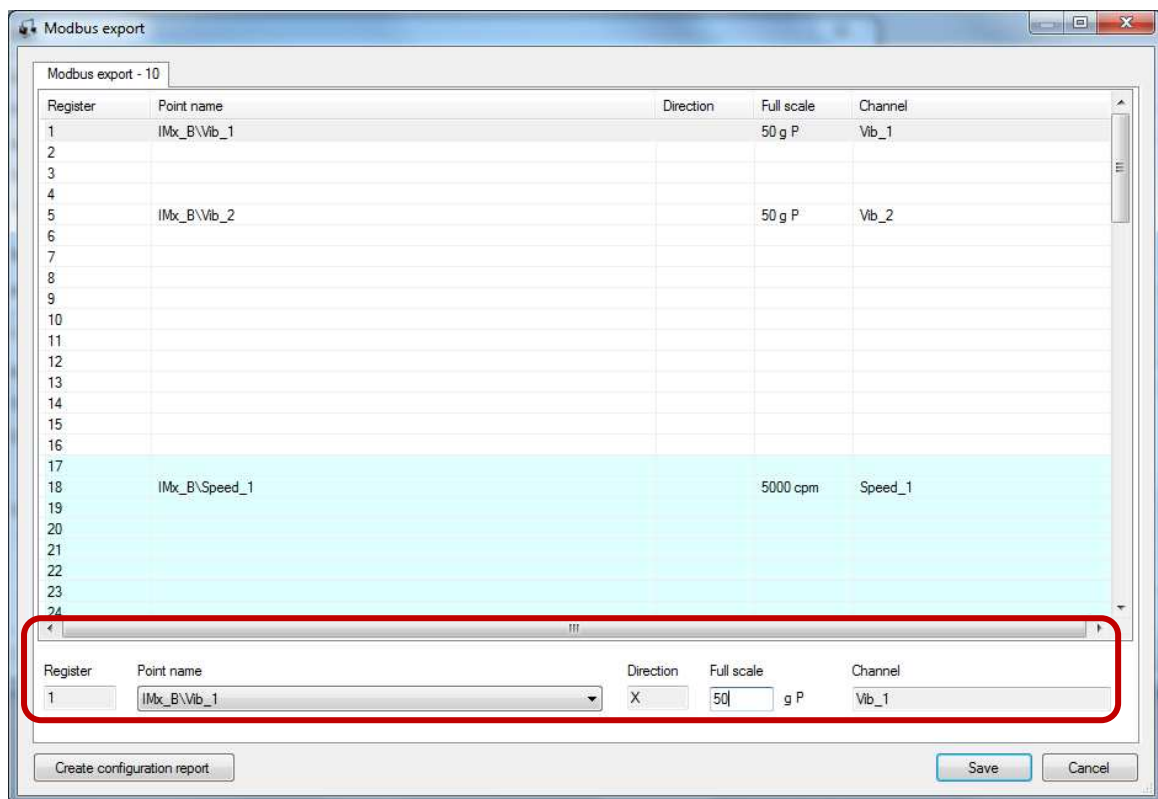

Figure 4 - 14.
Example of Modbus Export Dialog.

Use the fields at the bottom, below the Modbus Register list, to enter data and select the **Point name**. The Modbus Export selections can include some or all of the measured points from the analogue and digital channels of an IMx device; the speed measurements from the digital channels; the relay mask, warning mask, alarm mask, heartbeat, system information status, digital input status and System diagnostic status.

Modbus registers 1-16, 31-128 are freely configurable.

Modbus registers 17-24 are reserved for speed points.

Modbus registers 25-30 are reserved for the output of relay mask, warning mask, alarm mask, heartbeat, system information, digital input status and System diagnostic status.

- As stated above, when Float 32 bit is chosen as the **Value type**, only odd register numbers are used in the **Modbus export** dialog and a maximum of four speed channels are allowed, depending on the IMx model.

The **Create configuration report** button (at the lower left of the dialog) saves the information currently visible in the Modbus configuration table for documentation purposes. Click **Create configuration report** to save a file in CSV format, the report provides a record of how the registers have been configured on a device.

Configuring IEC External Communication

When @ptitude Observer has the license module "IEC 61850" installed, the option of configuring External communication as IEC 61850 MMS is enabled.

The following IMx models allow the External Communication **Type** to be **IEC61850 MMS**: IMx-W, IMx-C, IMx-S, IMx-T, IMx-B, IMx-16Plus and IMx-8.

- IEC 61850 is a standard for the design of electrical substation automation. IEC 61850 is a part of the International Electrotechnical Commission's (IEC) Technical Committee 57 (TC57) reference architecture for electric power systems.

Attempting to select IEC61850 MMS as the Type without having the appropriate device model or license key, will cause a message to display stating: To use this feature an extension of your license key is required.

When IEC61850 MMS is enabled, the additional **External communication** settings must be configured.

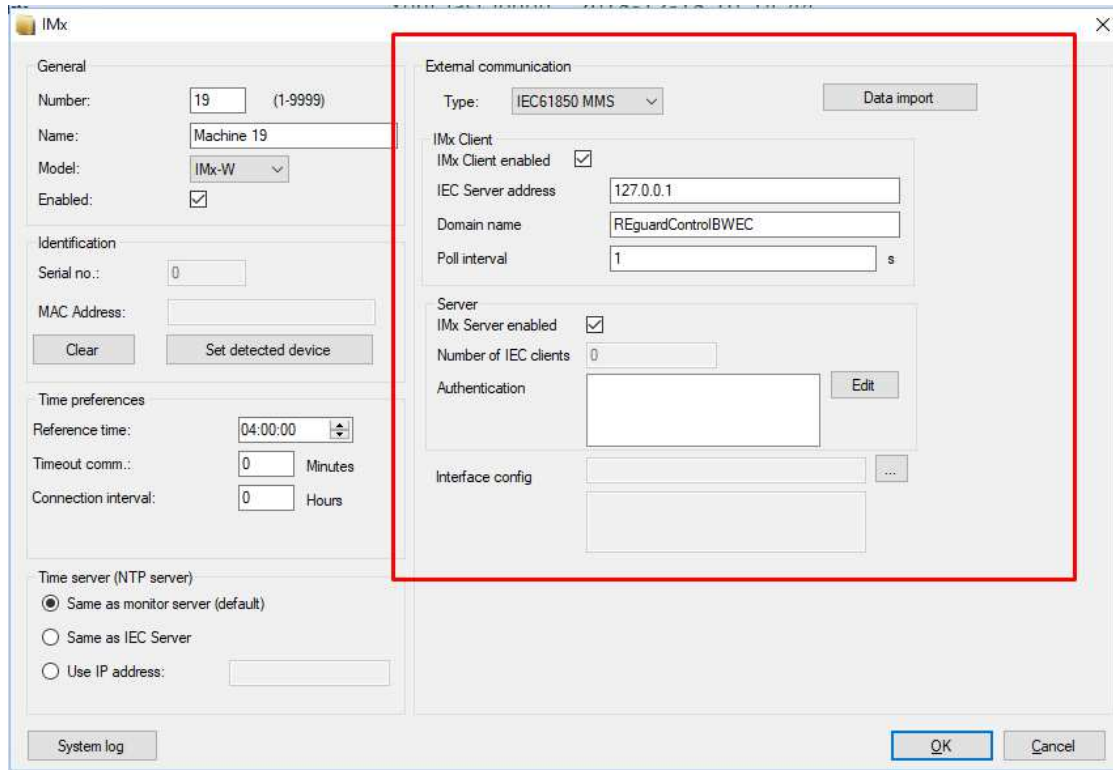

Figure 4 - 15.
Example of Create IMx Screen with IEC61850 MMS Enabled.

- Set up the IMx to communicate as a **Client**, requesting data from the IEC controller server:
 - Select (check) the **IMx Client enabled** checkbox to enable the IMx to communicate with the applicable IEC controller as a client.
 - Enter the IEC controller IP address in the **IEC Server address** text box.
 - Enter the IEC controller **Domain name**.
 - Enter the frequency, in seconds, with which the IMx will ask for data from the IEC controller in the **Poll interval** text box.
- Set up the IMx to communicate as a **Server**, providing data to the IEC controller server:
 - Select (check) the **IMx Server enabled** checkbox to enable the IMx to communicate with the applicable IEC controller as a server.
 - Enter the number of clients (up to three) that will connect to the IMx in the **Number of IEC clients** text box.
 - Click the **Edit** button next to the **Authentication** text box to access a **Password list** dialog, where it is possible to add and manage up to three usernames and passwords for access to the applicable clients.



Figure 4 - 16.
Example of Password List Dialog.

- Click the browse (ellipsis) button next to the **Interface config** text box to locate and attach the appropriate parameters (.iec) file. This special file contains coded parameters that the IMx will require to successfully read and understand data from the server.

Once the IEC is configured, continue with configuration of the appropriate external channels.

- The appropriate license key is required to make any change to the IEC external communication configuration. If the IMx device is already configured for IEC external communication but there is not an appropriate license key, the external communication fields shown in the figure below will be read only.

Configuring External Channels

External channels are IMx channels based on externally sourced data. The external channel setup window applies to all types of IMx devices and all types of external communication so the layout differs depending on what DAD is used and how external communication is configured.

Modbus - Supports 32 external channels. Where the IMx is a Modbus master; this supports data from multiple slaves but no access to these registers is available to connections where the IMx is also a Modbus slave. Makes no distinction between analogue/digital (do not use the same external channel in both types because they cannot be configured differently).

GPS(GPS50M) – A specific configuration supporting the external GPS module available from SKF.

IEC61850 - Supports 32 external analogue channels.

IMx-R and RB06 TSI - Supports both analogue and digital at the same time: 32 analogue and 4 digital channels.

To access the Modbus external communication channels dialog, click the **Data Import** button.

The first example below, shows the external communication channels of an IMx-8 device setup as a Modbus master.

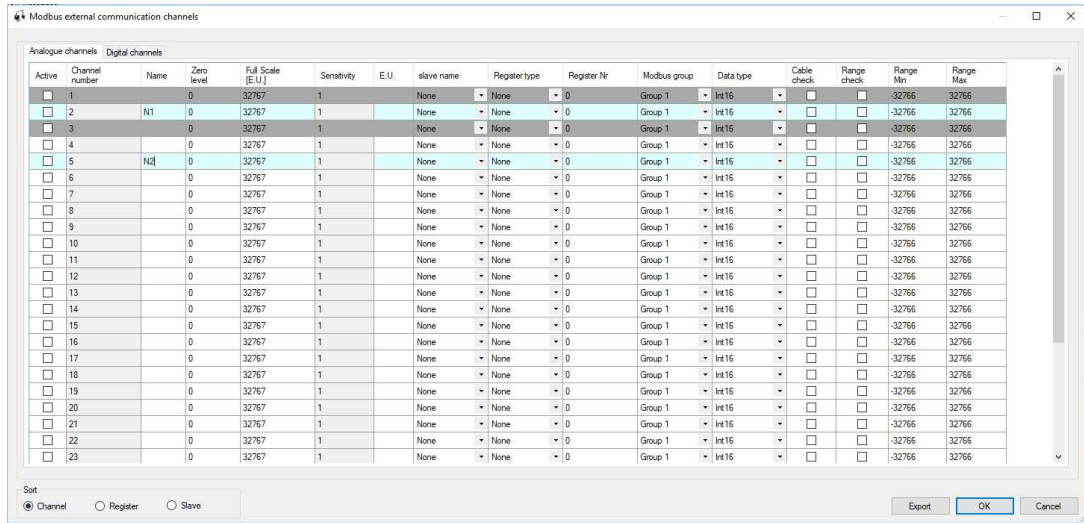

Figure 4 - 17.
 External Channels with Modbus Master Setup.

The Modbus configuration dialog has three sorting buttons, one for sorting by **Channel** number another for sorting by **Register** type and number and one for sorting by **Slave name**. The **Slave name** column has a drop-down control to allow the selection of any of the configured external slave devices.

In addition to **Save** and **Cancel** buttons, **Export** exports the configuration to a CSV file format.

When setting **Full Scale**, the sensitivity of the channel is calculated from range value and full scale value.

$$\text{Maximum of (abs(Range min), abs(Range(max)))/full scale.}$$

In the **Data Type** column, configure Modbus to read int16, int32, Uint16, Uint32 or Float.

- If the data type Float is selected, the Full Scale cell becomes read only and a sensitivity value is entered instead.

When **Cable check** or **Range check** are not enabled with a checkmark, the **Range Min** and **Range Max** are ignored.

Modbus Group can be applied to the Modbus registers. These groups are used to optimise the data transfer and avoid unreadable registers. Up to three groups per slave, each with a maximum span of 125 registers are supported. Make sure to select a different Modbus group if this register range is exceeded, if there are unreadable registers to avoid or if the register type changes. For example:

- Ch1 > Holding > Reg Nr. 101 => Group 1
- Ch13 > Holding > Reg Nr. 201 => Group 1
- Ch26 > Holding > Reg Nr. 409 => Group 2
- Ch27 > Input > Reg Nr. 150 => Group 3

- A group cannot contain both holding and input register types.

In the Analogue channels tab, the channels that are configured as digital have a grey background and cannot be edited. Similarly, in Digital channels tab, the channels that are configured as analogue have a grey background and cannot be edited.

When one row is selected, right click with the mouse to open a context menu. The menu option **Clear row** resets the selected row to its default settings and marks the channels as not modified.

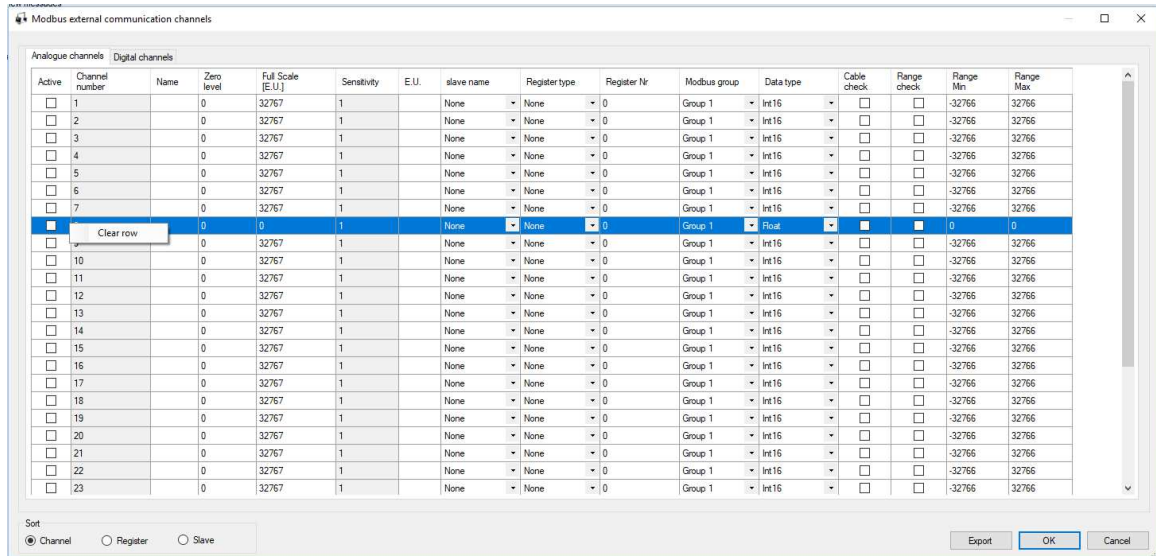

Figure 4 - 18.
Clear Row Option in the Context Menu.

System Configuration Creating IMx/MasCon Devices and Channels

The second example below shows the external communication channels of an IMx-8 device set up as a Modbus slave.

Active	Channel number	Name	Zero level	Full Scale [E.U.]	Sensitivity	E.U.	slave name	Register type	Register Nr	Modbus group	Data type	Cable check	Range check	Range Min	Range Max
<input type="checkbox"/>	1		0	100	327,67	V	None	Holding	1	Group 1	Int16	<input checked="" type="checkbox"/>	<input checked="" type="checkbox"/>	-32766	32766
<input type="checkbox"/>	2		0	32767	1		None	Holding	2	Group 1	Int16	<input checked="" type="checkbox"/>	<input checked="" type="checkbox"/>	-32766	32766
<input type="checkbox"/>	3		0	32767	1		None	Holding	3	Group 1	Int16	<input checked="" type="checkbox"/>	<input checked="" type="checkbox"/>	-32766	32766
<input checked="" type="checkbox"/>	4		0	4965	6,599597	V	None	Holding	4	Group 1	Int16	<input checked="" type="checkbox"/>	<input checked="" type="checkbox"/>	-32766	32766
<input type="checkbox"/>	5		0	32767	1		None	Holding	5	Group 1	Int16	<input checked="" type="checkbox"/>	<input checked="" type="checkbox"/>	-32766	32766
<input type="checkbox"/>	6		0	32767	1		None	Holding	6	Group 1	Int16	<input checked="" type="checkbox"/>	<input checked="" type="checkbox"/>	-32766	32766
<input type="checkbox"/>	7		0	32767	1		None	Holding	7	Group 1	Int16	<input checked="" type="checkbox"/>	<input checked="" type="checkbox"/>	-32766	32766
<input type="checkbox"/>	8		0	32767	1		None	Holding	8	Group 1	Int16	<input checked="" type="checkbox"/>	<input checked="" type="checkbox"/>	-32766	32766
<input type="checkbox"/>	9		0	32767	1		None	Holding	9	Group 1	Int16	<input checked="" type="checkbox"/>	<input checked="" type="checkbox"/>	-32766	32766
<input type="checkbox"/>	10		0	32767	1		None	Holding	10	Group 1	Int16	<input checked="" type="checkbox"/>	<input checked="" type="checkbox"/>	-32766	32766
<input type="checkbox"/>	11		0	32767	1		None	Holding	11	Group 1	Int16	<input checked="" type="checkbox"/>	<input checked="" type="checkbox"/>	-32766	32766
<input type="checkbox"/>	12		0	32767	1		None	Holding	12	Group 1	Int16	<input checked="" type="checkbox"/>	<input checked="" type="checkbox"/>	-32766	32766
<input type="checkbox"/>	13		0	32767	1		None	Holding	13	Group 1	Int16	<input checked="" type="checkbox"/>	<input checked="" type="checkbox"/>	-32766	32766
<input type="checkbox"/>	14		0	32767	1		None	Holding	14	Group 1	Int16	<input checked="" type="checkbox"/>	<input checked="" type="checkbox"/>	-32766	32766
<input type="checkbox"/>	15		0	32767	1		None	Holding	15	Group 1	Int16	<input checked="" type="checkbox"/>	<input checked="" type="checkbox"/>	-32766	32766
<input type="checkbox"/>	16		0	32767	1		None	Holding	16	Group 1	Int16	<input checked="" type="checkbox"/>	<input checked="" type="checkbox"/>	-32766	32766
<input type="checkbox"/>	17		0	32767	1		None	Holding	17	Group 1	Int16	<input checked="" type="checkbox"/>	<input checked="" type="checkbox"/>	-32766	32766
<input type="checkbox"/>	18		0	32767	1		None	Holding	18	Group 1	Int16	<input checked="" type="checkbox"/>	<input checked="" type="checkbox"/>	-32766	32766
<input type="checkbox"/>	19		0	32767	1		None	Holding	19	Group 1	Int16	<input checked="" type="checkbox"/>	<input checked="" type="checkbox"/>	-32766	32766
<input type="checkbox"/>	20		0	32767	1		None	Holding	20	Group 1	Int16	<input checked="" type="checkbox"/>	<input checked="" type="checkbox"/>	-32766	32766
<input type="checkbox"/>	21		0	32767	1		None	Holding	21	Group 1	Int16	<input checked="" type="checkbox"/>	<input checked="" type="checkbox"/>	-32766	32766
<input type="checkbox"/>	22		0	32767	1		None	Holding	22	Group 1	Int16	<input checked="" type="checkbox"/>	<input checked="" type="checkbox"/>	-32766	32766
<input type="checkbox"/>	23		0	32767	1		None	Holding	23	Group 1	Int16	<input checked="" type="checkbox"/>	<input checked="" type="checkbox"/>	-32766	32766

Figure 4 - 19.
External Channels with Modbus Slave Setup.

When Modbus is enabled in slave mode, all fields with a light or dark grey background are not editable.

Note that external communication channels are not available to an IMx in slave mode, if it is also configured as a Modbus master device (sole use of these 32 channels by the connection in master mode).

Also, be aware that it is not allowed to write to IMx registers when the IMx is a slave to multiple masters.

The next example below shows the external communication channels of an IMx-16Plus device set up to communicate with a GPS(GPS50M), slave.

Active	Channel number	Name	Zero level	Full Scale [E.U.]	Sensitivity	E.U.	slave name	Register type	Register Nr	Modbus group	Data type	Cable check	Range check	Range Min	Range Max
<input checked="" type="checkbox"/>	1	Latitude	0	0	1	'	GPS	Holding	101	Group 1	Float	<input type="checkbox"/>	<input type="checkbox"/>	0	0
<input checked="" type="checkbox"/>	2	Longitude	0	0	1	'	GPS	Holding	103	Group 1	Float	<input type="checkbox"/>	<input type="checkbox"/>	0	0
<input checked="" type="checkbox"/>	3	Altitude	0	0	1	m	GPS	Holding	105	Group 1	Float	<input type="checkbox"/>	<input type="checkbox"/>	0	0
<input checked="" type="checkbox"/>	4	UTC	0	0	1		UTC	Holding	107	Group 1	Float	<input type="checkbox"/>	<input type="checkbox"/>	0	0
<input checked="" type="checkbox"/>	5	HDOP	0	0	1	Value	GPS	Holding	2131	Group 2	Float	<input type="checkbox"/>	<input type="checkbox"/>	0	0
<input checked="" type="checkbox"/>	6	VDOP	0	0	1	Value	GPS	Holding	2133	Group 2	Float	<input type="checkbox"/>	<input type="checkbox"/>	0	0
<input checked="" type="checkbox"/>	7	2D/3D Fix	0	2147483647	1	Value	GPS	Holding	2103	Group 2	Int32	<input type="checkbox"/>	<input type="checkbox"/>	-2147483646	2147483646
<input checked="" type="checkbox"/>	8	Velocity	0	0	1	knots	GPS	Holding	2207	Group 3	Float	<input type="checkbox"/>	<input type="checkbox"/>	0	0
<input checked="" type="checkbox"/>	9	Direction	0	0	1	'	GPS	Holding	2209	Group 3	Float	<input type="checkbox"/>	<input type="checkbox"/>	0	0

Figure 4 - 20.
External Channels when external communication **Type** is GPS(GPS50M).

This is a fixed/standard configuration for retrieving GPS position data from the device. When switching from **Type** Modbus to GPS(GPS50M) a warning message will be displayed because any existing Modbus configuration will be lost.

The example below shows the channels when external communication **Type** is set to IEC61850.

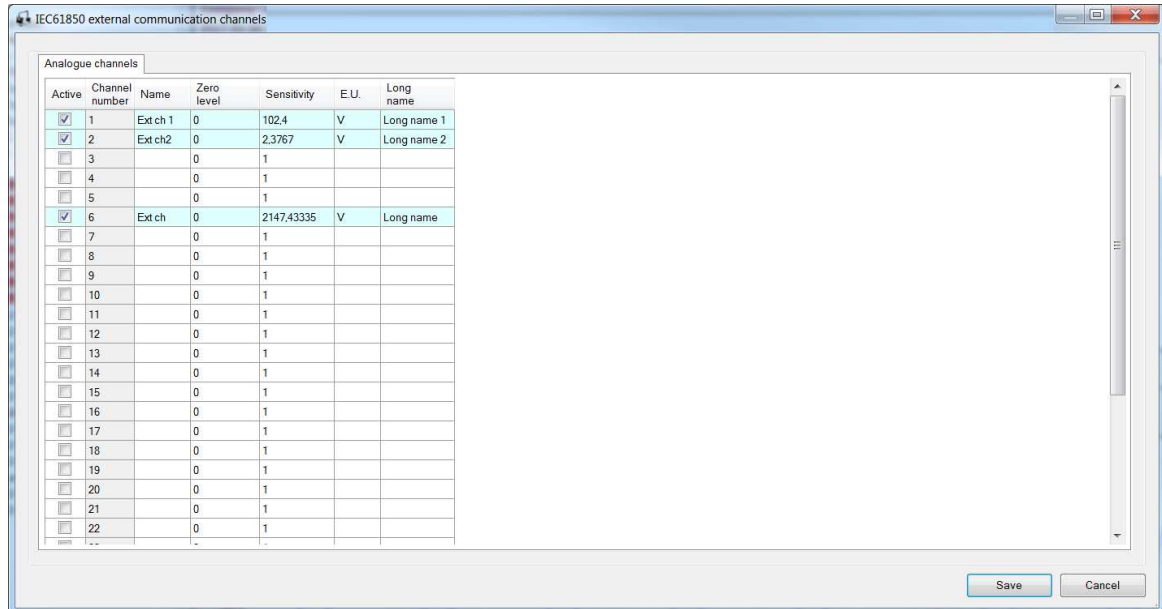

Figure 4 - 21.
External Channels with IEC Setup.

When external communication is set to IEC61850, the column **Long name** is visible. Use this column to configure the name of the IEC data that should be read.

Edit

Edit function allows the settings of an existing device within the selected database, to be changed. The definitions of attributes are the same as in [Create Device](#). All settings except **Number** field can be edited.

The following attribute is available only for Edit function:

Convert to IMx converts an existing MaxCon16 to an IMx device.

- Note that after the conversion, the device type cannot be reverted.

Delete

Delete function allows the deletion of an existing device of the selected database. However, before a device can be deleted, all the attached measurement points and device channels must be deleted first.

Copy

Copy function allows all the settings of an existing device to be copied to a new device. Note, a unique device number for the new device must be selected from the list of system generated numbers.

Synchronize

Synchronize function synchronizes the IMx/MasCon device of the selected database by sending a newly generated, complete setup file from the local database where setup changes are stored to a remote device such as a remote controlled IMx/MasCon16 device. The transmission is sent by the @ptitude Observer Monitor service. If this fails because of an error or a lack of time, then the IMx/MasCon device will be indicated as not synchronized. Not synchronized means that the system is yet to download the newer setup to the device.

After clicking **Synchronize**, Monitor generates a configuration and it checks whether the configuration needs the newer CPU type. If so; a system alarm is sent to Observer and Observer, then displays a communication error stating “Invalid Device Configuration”.

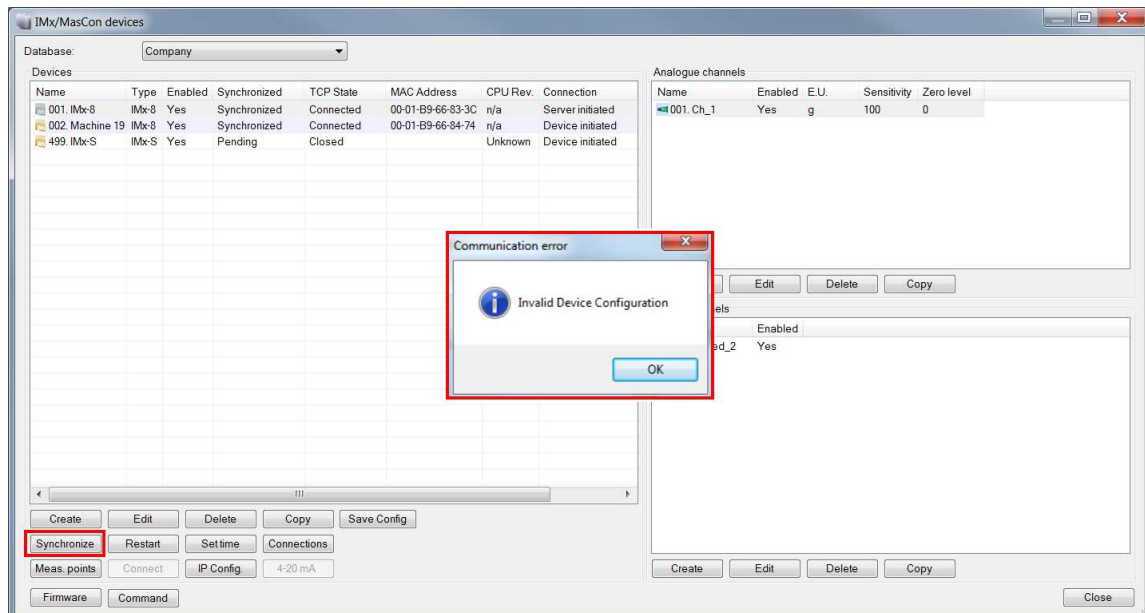

Figure 4 - 22.
Communication Error Displayed When CPU Type is Incorrect.

Restart

Restart function forces the device to perform a self-diagnostics boot-up stage and reinitialize all the channels and setup information.

Set Time

Set time function sets up a time on an IMx/MasCon16 device of the selected database and adjusts any incorrect date and time. Since IMx/MasCon16 devices do not use local computer time, this function is the way to synchronize devices' time to that of the computer from where the function was initiated.

Connections

Connections function produces a log of connection histories of the device. The log can be used to solve intermittent connection problems for an IMx/MasCon device.

There are different types of messages:

- **Error:** indicates that a communication error exists. It can be that the communication between the device and the @ptitude Observer Monitor is not stable or is unreliable.
- **Unknown:** indicates that the @ptitude Observer Monitor service has been closed unexpectedly, for example because of a loss of power to the @ptitude Observer Monitor.
- **Monitor restart:** indicates that the @ptitude Observer Monitor service has been closed normally.
- **Normal:** indicates that the IMx/MasCon device has been restarted normally.

Measurement Points

The Measurement points function provides a list of all measurement points available on the selected device and allows their enabled status to be set. This is an especially useful function for portable systems: to be able to change the status of measurement points using the same channels.

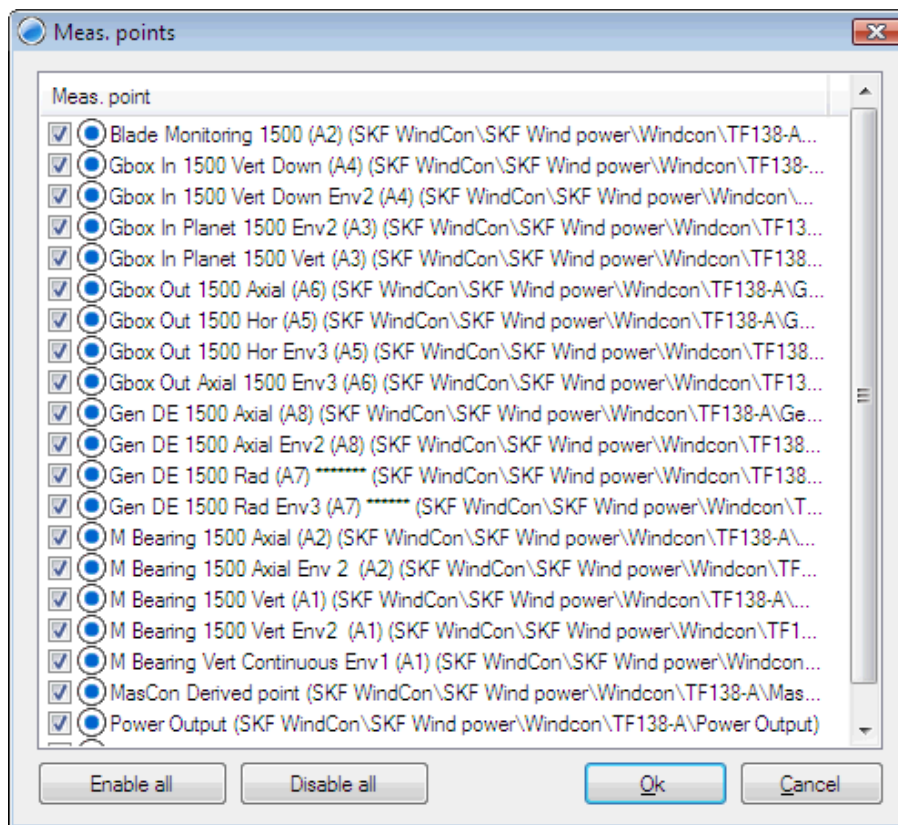

Figure 4 - 23.
Example of Measurement Points Status.

Enable or disable an individual measurement point by checking or un-checking each box or change the status of all the measurement points at once by using the **Enable all** or **Disable all** buttons.

- Note that each type of device has individual limitations for the number of active points and the number of active vibration

points. For more details see the manual for the specific device type.

Connect

Connect function connects an IMx/MasCon16 device to the @ptitude Observer Monitor for a specified time (in minutes). The "Connect" function can be used when devices have been configured to only connect once a day to the Monitor service (by configuring the "Connection Interval" parameter). This can be useful when changing the configuration or checking vibration data before the next scheduled connection time of the device.

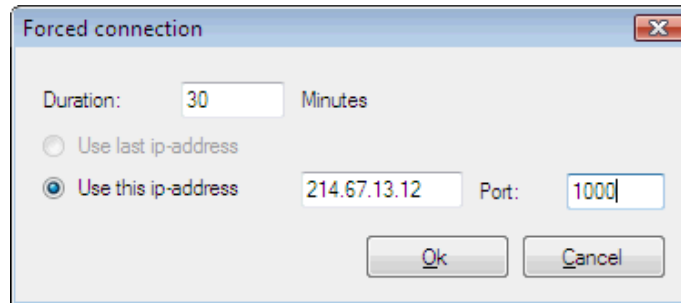

Figure 4 - 24.
Example of Forced Connection.

To communicate with the device between scheduled connections, the connection must be established manually from the server side through @ptitude Observer.

IMx/MasCon16 devices initiate communication to @ptitude Observer Monitor on TCP port 1000 which is the default port. However, do not confuse this with the @ptitude Observer Monitor port (configured through Observer On-line Device Configurator).

For example, use port forwarding to access devices behind a router;

- 11.22.33.44 port 1001 ---> 10.0.0.101 port 1000 for IMx #1
- 11.22.33.44 port 1002 ---> 10.0.0.102 port 1000 for IMx #2
- 11.22.33.44 port 1003 ---> 10.0.0.103 port 1000 for IMx #3

IP Configuration

IP Config. function sends a network configuration file to the selected IMx/MasCon16 device. To create an IP configuration that can be sent to a DAD (data acquisition device), the tool called On-line Device Configurator should be used. It is available in the Observer installation package and can be started from the start menu if it is installed. For more information, refer to "On-line Device Configurator User Manual".

4-20 mA

4-20 mA output can be configured for IMx-T. Channels can be initiated or edited with corresponding values of 4 to 20 mA along with an existing measurement point.

- More information can be found in "IMx-T User Manual".

Firmware

Firmware function opens the firmware interface for the database where it is possible to add and update firmware for the different types of data acquisition devices available in @ptitude Observer such as IMx, MasCon16 and MasCon48.

The firmware is automatically sent to the DAD when the DAD connects to the @ptitude Observer Monitor service next time. This means that it is not necessary to go through every DAD and upgrade it manually. To force all DAD to upgrade the firmware immediately, simply restart the @ptitude Observer Monitor service and force a restart of DAD by clicking on **Restart** as described in [Restart](#) in Creating IMx/MasCon Devices and Channels.

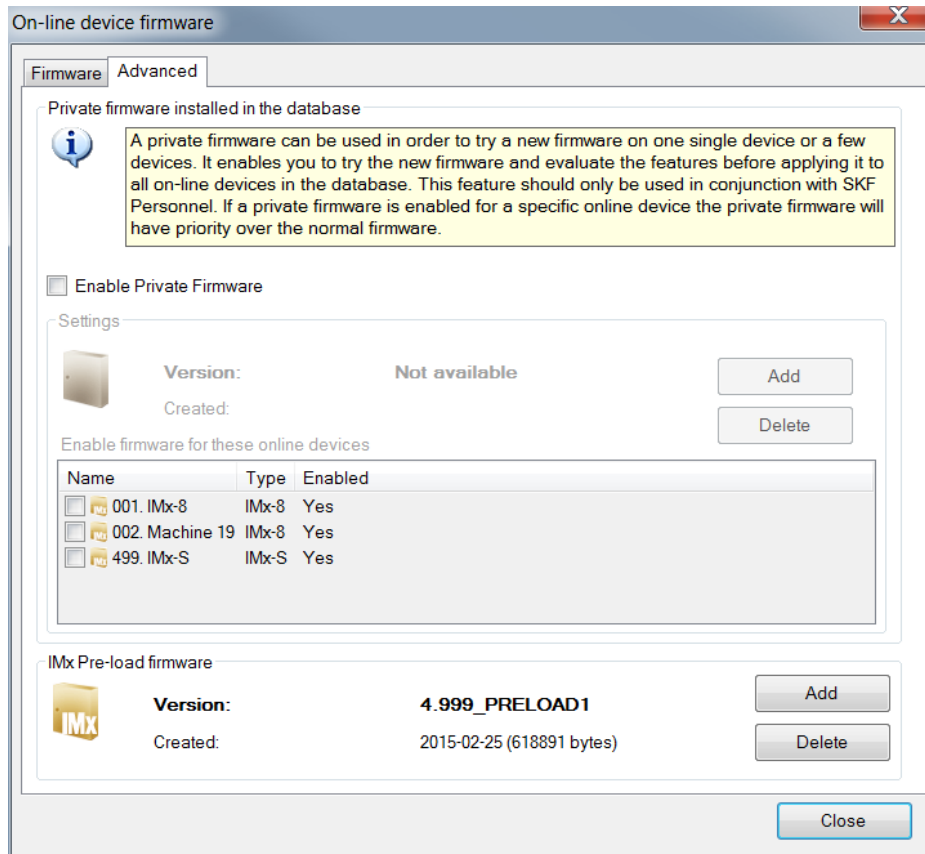

Figure 4 - 25.
 Example of Private Firmware.

Private firmware can be used to try a new firmware on a single device or a few devices. It is mostly used to try out new firmware progressively before applying the firmware across all devices or to try features designed for a specific application.

- Private firmware overrides normal firmware.

To utilise this interface, **Enable Private Firmware** box must be checked. Once the box is checked, private firmware settings can be added or deleted for the selected online devices.

Command

This button activates a command window that provides an interface to send commands to an IMx device. These commands can, for example, be used for viewing the network configuration of a device, (getcfg sys) or the device MAC address (get hw/macaddr).

When the command window is first opened, a help text is displayed that explains all the available commands and their usage. The figure below shows an example of that text:

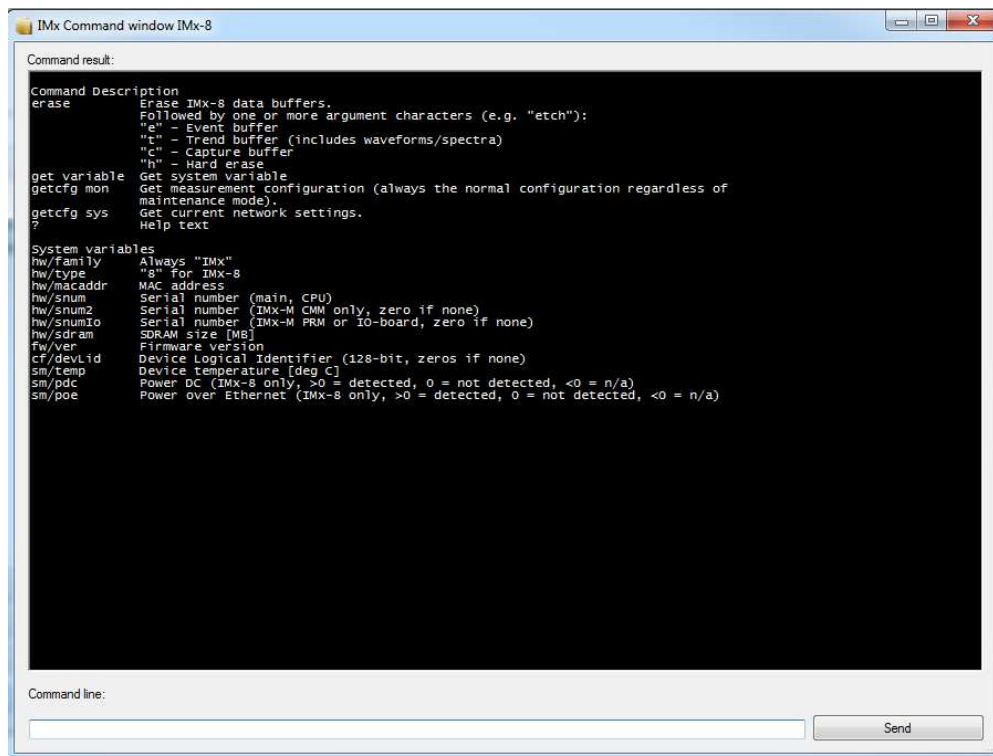

Figure 4 - 26.
Example of the Command window, Help text.

Use the command line area at the bottom of the window to type a command and the adjacent button to send. When a valid command is sent, it appears in the command window in bold and yellow with a leading time-date stamp. The response from the device will follow.

The command window is resizable and (when it extends past the extent of the window), scrollable. Information can be copied directly from the window. Note that the command functionality is only available for IMx devices and some commands are device specific, for example to an IMx-8, refer initial window help text.

Analogue Channels

Analogue channels interface provides a list of all the initiated analogue channels of the selected device along with their settings. It also allows a user to initiate new analogue channels and edit, copy and delete any existing analogue channel from the list.

A channel is equal to a sensor input. To be able to initiate or edit a channel, the device to which the channel will belong must be created and configured first.

To create an Analogue Channel:

- Select a device from the list of IMx/MasCon devices and then click **Create** below the **Analogue Channels** list.

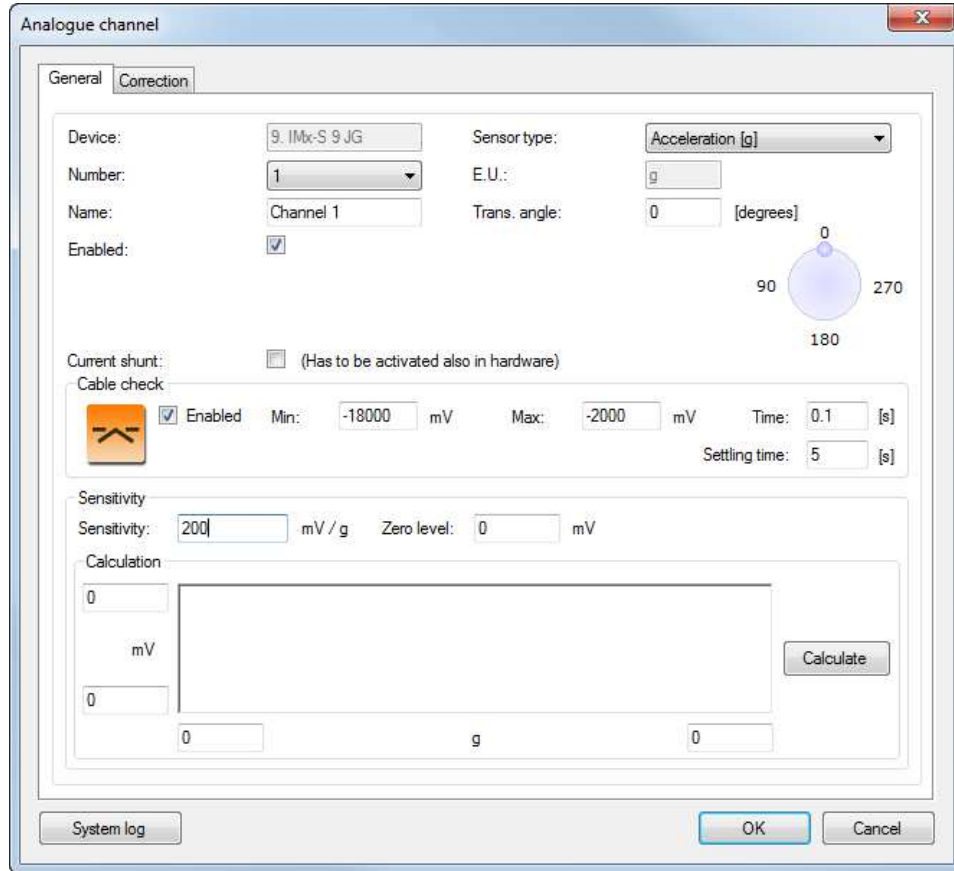

Figure 4 - 27.
Example of Create Analogue Channel Screen.

General Tab

Device is the name of the selected device (not editable).

Number is a unique number for the physical input channel on the device being configured.

Name of the channel can be used as a reference by the software.

Enabled indicates the status of the channel whether it is enabled or disabled.

IEC Long Name is for the channel's data source reference excluding domain name for IEC-enabled devices.

Isolated is used for external signals such as measuring process parameters for MasCon16 device's channels 15 and 16.

ICP Current feed indicates whether to use the IMx device to power the probe or not (normally on accelerometers only and applies to IMx-W, IMx-T, IMx-8, IMx-16Plus and IMx-Rail). For MasCon48 devices, this is achieved by DIP switches on each channel on the vibration/analogue card.

Sensor type is a sensor signal type which can be selected from the drop-down list.

- The inclusion of some sensor types in the drop-down list is conditional on a specific device type and even, device channel. For example, sensor types PT1000 (C) and PT1000 (F) are only available for channels 9 to 16 of an IMx-16Plus (or IMx-Rail).

E.U. (Engineering Unit) is a measurement unit which can be set only if sensor signal is set to Other, for example, a pressure sensor.

Trans. angle is the angle of the sensor mounted on a device, relative to twelve o'clock. A consistent convention should be adopted, for example 'as viewed from driving to driven machine'.

Current shunt is available for IMx devices where a shunt resistor has been added to the channel input. If a resistor has been added or enabled, check this field.

- For IMx-W device's channel 15 and 16, IMx-T and IMx-S this is achieved by appropriate DIP switch setting. For IMx-8, IMx-16Plus and IMx-Rail an external 250-ohm resistor must be fitted.

Cable check will raise a system alarm from a cable fault if the signal goes outside of the range.

Enabled: Check the box to allow the system to perform a cable check on the channel before a measurement is taken.

Min: The minimum output range of the sensor.

Max: The maximum output range of the sensor.

Time: The duration of the cable check measurement.

Settling time: Upon detecting a sensor bias output voltage (BOV) out of range and entering a cable fault alarm status, the duration for which the IMx will remain in this status once sensor power is restored. A configured Settling time can prevent false alarms in case the sensor's actual settling time extends beyond the measurement time and alarm hysteresis. The Settling time feature also helps IMx ignore drifting signals from broken sensors that may erroneously enter the proper BOV range.

- The Settling time value must be between “0” and “60” seconds. The default is 1 second.

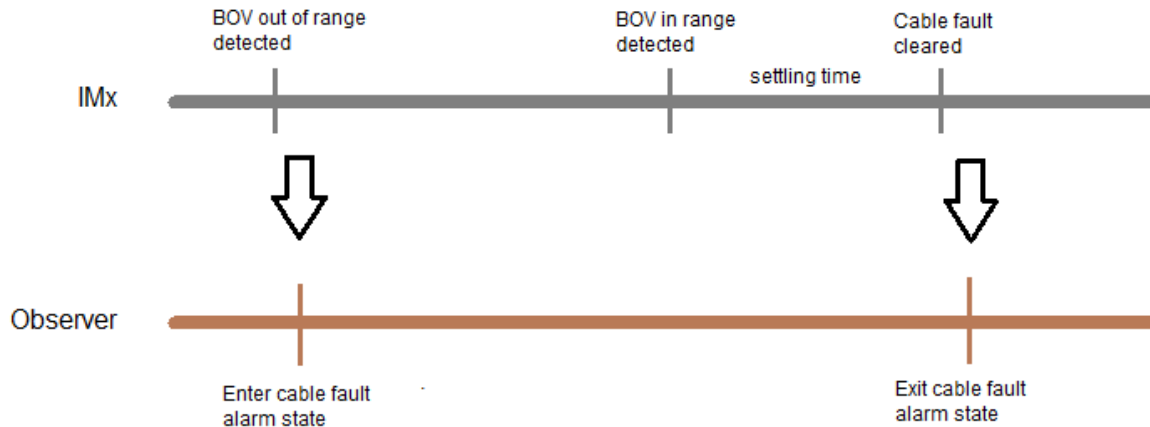

Figure 4 - 28.
Settling Time Diagram.

Sensitivity and Zero level are properties of the sensor which also can be calculated by filling in the lower part of the screen and pressing the **Calculate** button.

Sensitivity: Specifies the volt or amp ratio to the measurement unit.

Zero level: Which value in volt or amp should be equal to zero in the measurement unit.

Correction Tab

When using eddy current (displacement) probes there is an option to correct or compensate for shaft runout as follows:

Frequency: Four frequencies at which corrections are made.

Phase: Phase value for each frequency.

Amplitude: Amplitude for each frequency.

This function is used mostly for MasCon48 turbine monitoring. Refer also to [Configuring Runout Compensation](#).

To edit an Analogue Channel:

- Select a device from the list of IMx/MasCon devices to get the list of all the corresponding analogue channels.
- Select a channel to edit, then click **Edit**.

All the fields in edit mode are the same as in **Initiating an Analogue Channel**, described above.

- Any setting except **MasCon**, **Number**, **Sensor type** and **E.U.** attributes, may be edited.

To delete an Analogue Channel:

- Select a device from the list of IMx/MasCon devices to get the list of all the corresponding analogue channels.
- Select a channel to delete and then click **Delete**.
 - Note that a channel cannot be deleted if it is in use by one or more measurement points.

To copy an Analogue Channel:

- First select a device from the list of IMx/MasCon devices to get the list of all the corresponding analogue channels.
- Select a channel to copy to a new channel, then click **Copy**.
- Choose a channel number for the new channel from the drop-down list, then click **Ok**.

Digital Channels

Digital channels interface provides a list of all the configured digital channels of the selected device along with their settings. It also allows the user to initiate new digital channels and edit, copy and delete any existing digital channel from the list.

To create a Digital Channel:

- Select a device from the list of IMx/MasCon devices and then click **Create** in the digital channels window.

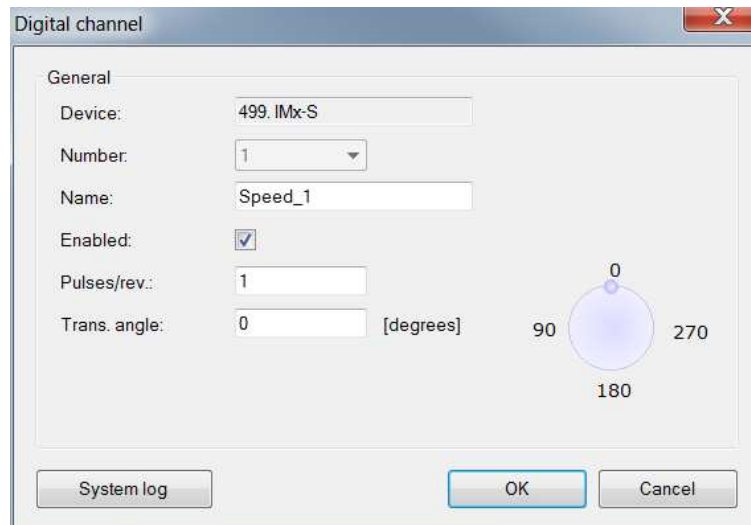

Figure 4 - 29.
Example of Initiate a Digital Channel.

MasCon is the name of the selected IMx/MasCon device (not editable).

Number is a unique number for the physical input channel on the device being configured.

Name is the name of the channel which the software can use as a reference.

Enabled indicates the status of the channel whether it is enabled or disabled. Enabled status activates the channel for measurement points.

Pulses/rev. is the number of pulses this sensor receives per shaft revolution.

Trans. angle is the angle of the sensor mounted, relative to twelve o'clock. A consistent convention should be adopted, for example 'as viewed from driving to driven machine'.

Sensor feed indicates whether to supply sensor power or not.

To edit a Digital Channel:

- First select a device from the list of IMx/MasCon devices to get the list of all the corresponding digital channels.
- Select a channel to edit and then click **Edit**.

All the fields in edit mode are the same as in **Initiating a Digital Channel**, described above.

- Any setting except **MasCon** and **Number** attributes, can be edited.

To delete a Digital Channel:

- First select a device from the list of IMx/MasCon devices to get the list of all the corresponding digital channels.
- Select a channel to delete, then click **Delete**.
 - Note that a channel cannot be deleted if it is in use by measurement point(s).

To copy a Digital Channel:

- Select a device from the list of IMx/MasCon devices to get the list of all the corresponding digital channels.
- Select an existing channel to copy to a new channel, then click **Copy**.
- Choose a channel number for the new channel from the drop-down list, then click **Ok**.

Machine Properties

Setting up machine data can be done at the machine properties screen. This information is only text based and is not used by analysis tools in @ptitude Observer. However, this information can be included in reports and other printouts.

To get to machine properties screen, perform one of the following options:

- Create a machine from scratch. Refer to [Machine](#) under Building a Hierarchy View in System Configuration.
- Click the right mouse button on a machine in the hierarchy view, then select **Properties**.
- Select a machine in the hierarchy view first, click **Edit** on the toolbar, then select **Properties**.
- Select a machine in the hierarchy view first, then click  **Properties** icon on the toolbar.

General Tab

The screenshot shows a software dialog box titled "Machine properties". It has several tabs: "General", "Extended Information", "Diagnosis", "Protean Diagnoses", "Attachments", "Advanced", and "*Machine Parameters". The "General" tab is selected. Inside the dialog, there is a "Settings" section with a gear icon. The fields are: "Name:" with the value "Motor 167-A"; "Description:" which is empty; "Machine code:" with the value "125000"; and "ISO class:" with a dropdown menu showing "II". At the bottom right of the dialog are "OK" and "Cancel" buttons.

Figure 4 - 30.
Example of General Machine Properties.

- Enter **Name**, **Description**, **Machine code** and **ISO** (International Organization for Standardization) **class**.
 - The ISO classes are based on SS-ISO 2372 (Vibration and shock - Basis for specifying evaluation of vibration).

Extended Information Tab

The screenshot shows a 'Machine properties' dialog box with the 'Extended Information' tab selected. The dialog contains the following fields:

	Driving unit:	Driven unit:	Transmission:
Manufacture:	LM,3 Bladed upwind	ABB	Flender AG
Type:	44m	Asuc 600/120	3-Stage planetary
Serial no.:		M2BG 1014	Peak 4280
Coupling:	Flange		
Power:	600kW		
Gear:			
Contact:	<None>		

Buttons: OK, Cancel

Figure 4 - 31.
Example of Extended Machine Properties.

- Enter **Manufacture** information, type and serial number of each driving device, driven device and transmission.
- Enter **Coupling** information of each driving device and driven device.
- Enter **Power** information on driving device.
- Enter **Gear** information on transmission.
- **Contact** can be used to set a contact or receiver for this particular machine. The contact can be used for general information, who to contact when there is a problem with the machine. It can also be used in [Event Case](#) reports.

The contact information is selected from the receiver library. For more information refer to [Receivers](#) under Libraries within Database menu item.

Diagnosis Tab

The Diagnosis tab enables the assignment of any diagnosis to the selected machine. Diagnoses are attached to machines by pre-defined diagnosis rules. To find out how to create diagnosis rules, refer to [Diagnosis Rules](#) under Database in Menu Items.

Each machine diagnosis that has been attached to a machine uses one or more measurement points as data input.

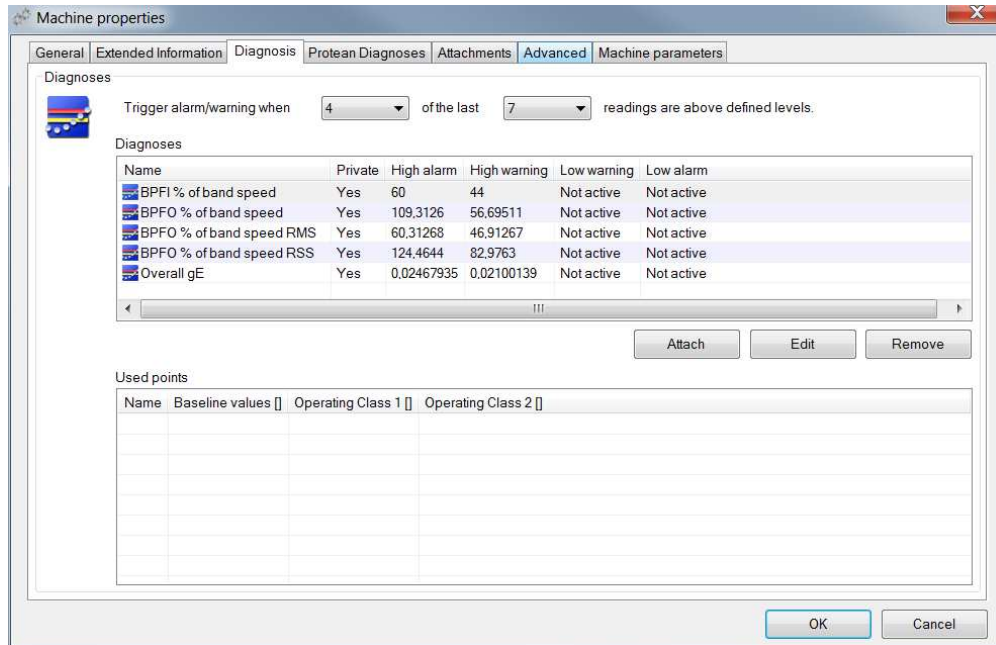

Figure 4 - 32.
 Example of Diagnosis Settings, 4 of the Last 7.

Trigger alarm/warning... configures the alarm hysteresis values used for calculating and triggering an alarm/warning. The method is to set the “Trigger alarm/warning when n (1 to 30) of the last n (1 to 30) readings are above defined levels.”

For example: If the setting is 4 out of 7 (the default values), then at least 4 measurements out of 7 must be over warning/alarm level before the alarm is set. When alarm is acknowledged, the alarm status is cleared. If the next measurement fulfils the configuration settings again, a new warning/alarm is generated.

Name identifies each diagnosis.

Private Privately attached diagnoses do not have a link to any diagnosis rules.

High alarm / High warning / Low warning / Low alarm are the alarm/warning level set in the diagnosis rules when configuring a diagnosis. Refer to [Diagnosis Rules](#) under Database in Menu Items

Edit edits the settings of the selected diagnosis. Refer to [Diagnosis Rules](#) under Database in Menu Items section for the description of settings.

Remove deletes the selected diagnosis from the list of diagnoses.

Attach attaches a diagnosis from a list of diagnoses.

Only one MGP (multiple gating point) can be added to any diagnoses set. If adding a second MGP is attempted, the following Input Error message displays. The message identifies the problem, one diagnosis at a time.

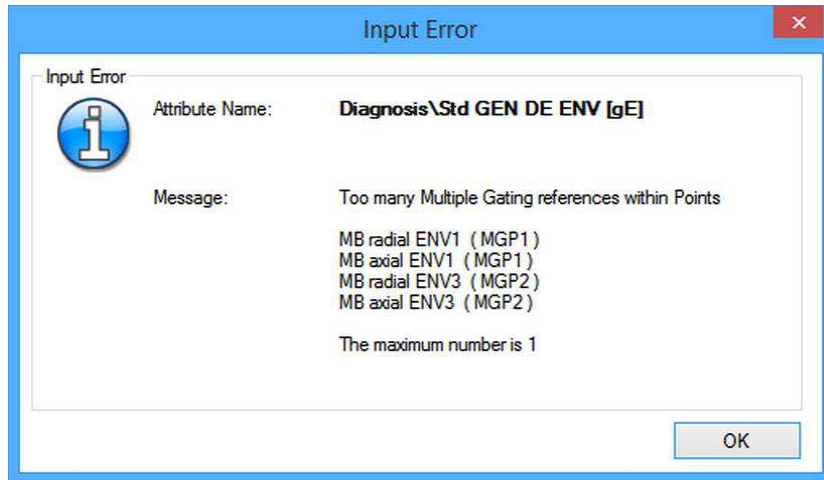

Figure 4 - 33.
Diagnosis Input Error, Too Many Multiple Gating References.

Protean Diagnoses Tab

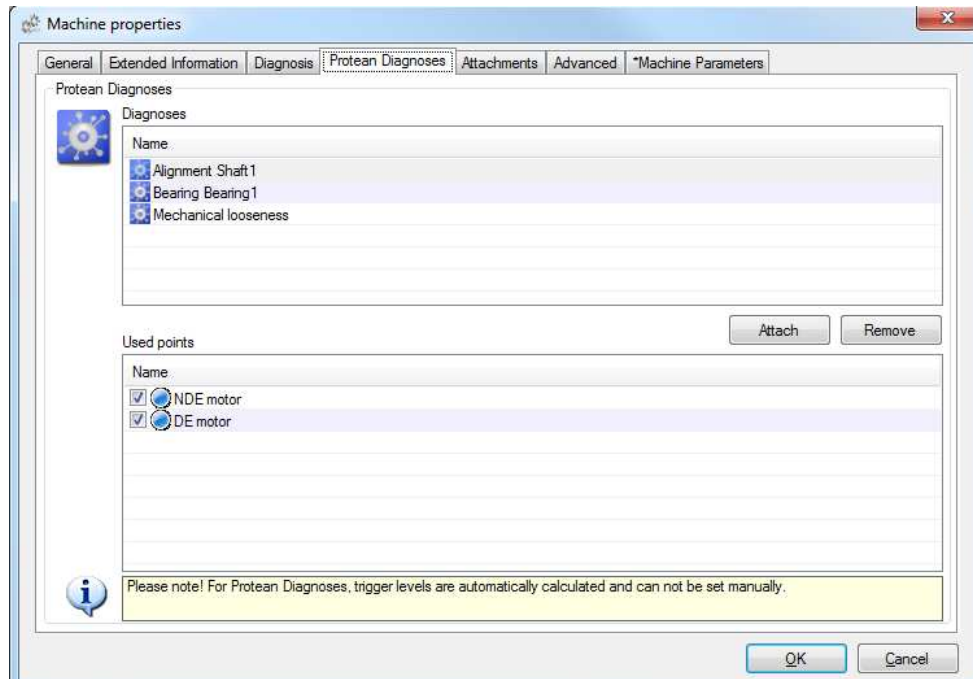

Figure 4 - 34.
Example of Protean Diagnoses settings.

The Protean Diagnoses tab is where predefined, SKF validated, Protean diagnoses can be applied or attached to the selected machine. These diagnoses have a self-learning algorithm that tracks both improvement and deterioration in machine condition and generates an alarm if the machine's health has worsened.

Name identifies each Protean diagnosis.

Remove deletes the selected Protean diagnosis from the machine

Attach attaches a Protean diagnosis from a list of available Protean diagnoses

Each Protean diagnosis that has been attached to a machine uses one or more measurement points as data input, (Used points).

Attachments Tab

Attachments are simply files that can be attached and stored with the selected machine. An attachment can be a .PDF file, Word report or even an MP3 file.

Advanced Tab

Conditional activation can be used to activate or deactivate measurements on the machine depending on a conditional input. The type of conditional input is an OPC Data tagging measurement point. This is particularly useful in test-bench monitoring where machine individuals and/or machine types (that is, gearbox individuals or gearbox types) needs to be tracked in a test-bench environment.

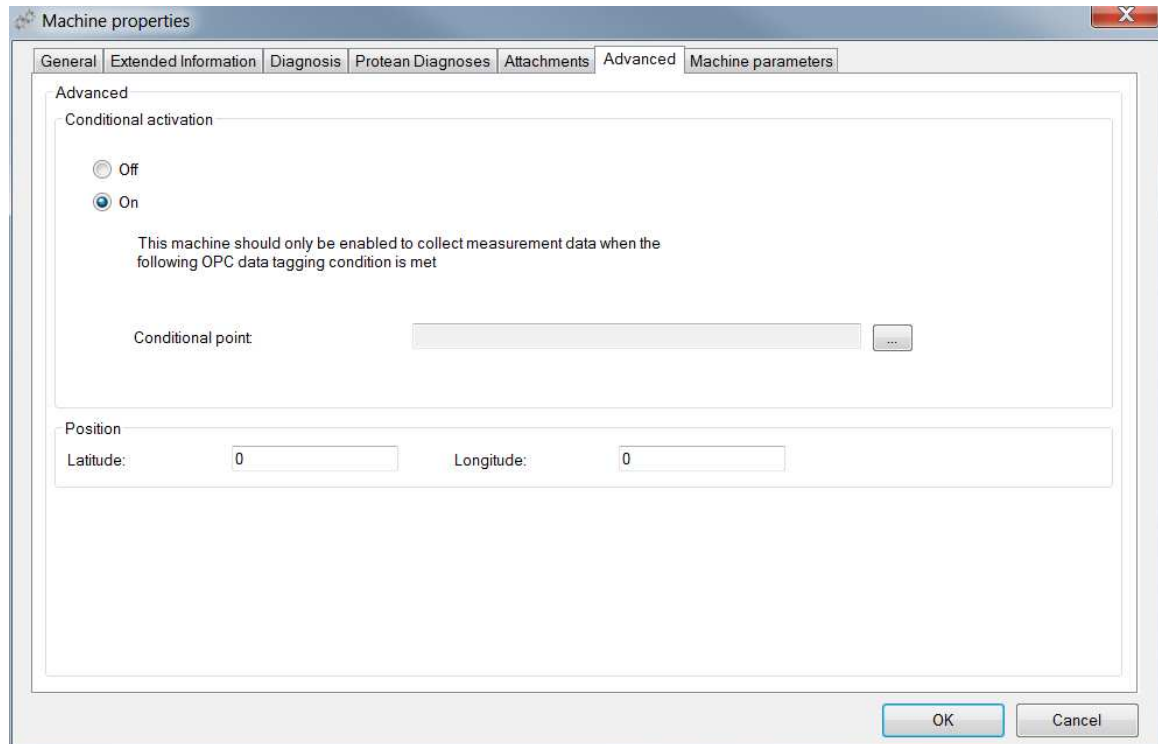

Figure 4 - 35.
Example of Advanced Settings.

To use the conditional activation, an OPC data tagging measurement point needs to be created and collect data from a specific OPC tag from an OPC Server.

When conditional activation is used on a machine and the tag value changes, it can take up to 30 seconds until the machine has been activated or deactivated.

Machine Parameters Tab

Machine Parameters are machine data that can be captured when using the IMx data acquisition device. The parameter data will be stored together with each dynamic measurement (FFT, Time waveform data) that is captured by the IMx.

For each IMx, up to 29 points can be used as machine parameters. These must be process parameter type points, not vibration points. They are selected by using a list in the **Machine Parameters** configuration window. They can be ordered in a user-defined list.

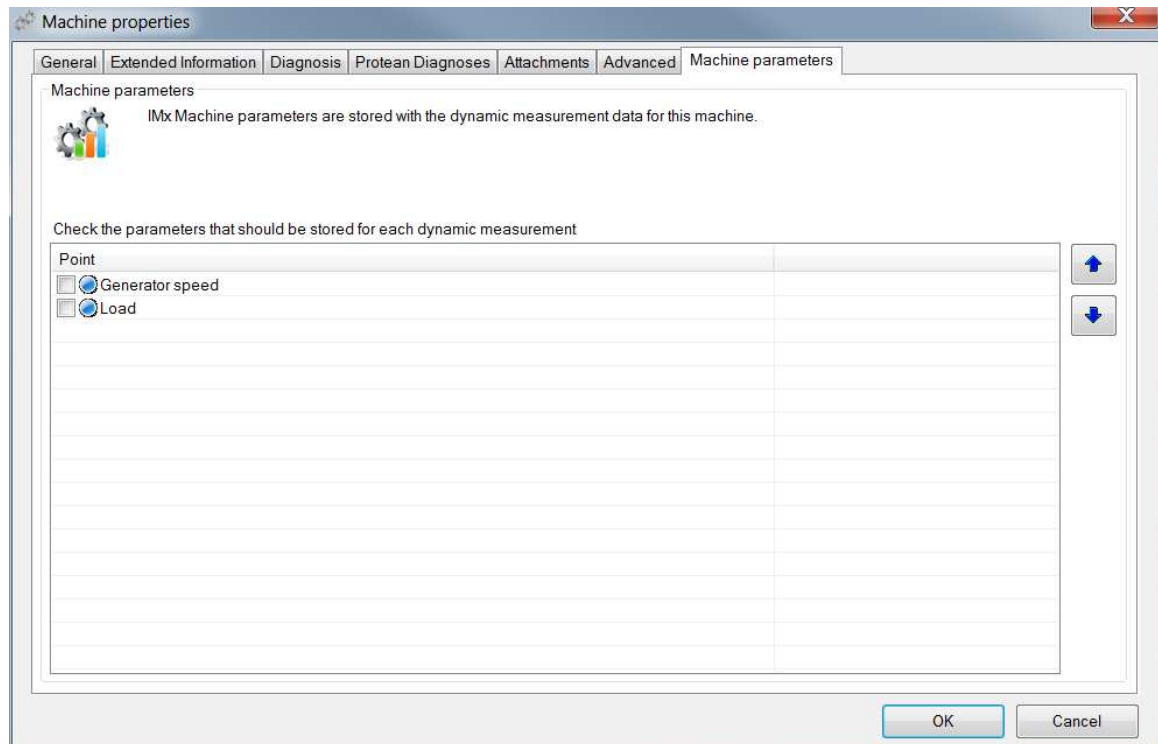

Figure 4 - 36.
Example of Machine Parameters Settings.

All machine parameters are:

- Displayed in the Measurement Date window (for each stored spectra/time waveform).
- Displayable in a trend plot like the existing three simultaneous parameters.
- Displayed in a separate list for the current cursor position in the trend plot (because of the large number of parameters, they cannot be displayed in the legend of each trend when displaying multiple vibration points in the same window).
- Selectable as the x-axis in a trend plot.
- Selectable for filtering in the buffer settings, one parameter at a time.

Creating OPC Server and OPC Channels

OPC stands for object linking and embedding (OLE) for process control. It is an open, flexible and plug-and-play software communication standard for modular software inter-operability in the automation industry. OPC is a specification that has been developed by a team of more than 120 different companies to produce an efficient specification for data/information standardisation.

OPC server enables software, such as @ptitude Observer, to route its data to OPC server. In return, OPC server stores and shares data from all the OPC clients.

Generally, there are two different generations of OPC; OPC (referred to as Standard OPC) and OPC UA.

There are two ways of working with OPC in conjunction with SKF @ptitude Observer.

- Using the [Internal Built-in OPC Server](#). In @ptitude Observer Monitoring Suite, there is a built-in OPC UA Server in the monitor service component. It can, if enabled, automatically publish all data that @ptitude Observer system captures.
- Using [External OPC Servers](#)

To be able to use OPC servers in @ptitude Observer, the user must set up a configuration for the available OPC servers in the @ptitude Observer, so that the @ptitude Observer Monitor service can recognize the OPC servers.

Not only can the @ptitude Observer Monitor handle IMx/MasCon devices, but it can also be the logical data gatherer/distributor for OPC. Therefore, it is not necessary to have the @ptitude Observer running to use OPC. However, it is necessary to set up the OPC servers and OPC channels in @ptitude Observer whilst the @ptitude Observer Monitor is connected to @ptitude Observer.

The following steps are an overview of the procedure using external OPC servers:

1. Install the OPC server and set up tags correctly according to the OPC manual.
2. In @ptitude Observer, create a connection to the OPC server by following: Adding an OPC Server, below.
3. In @ptitude Observer, create OPC channels to the OPC server created in step 2 by adding OPC channels as shown in Creating OPC Channels, below.

Warning: When using DBCS (double byte character set) operating systems, both the OPC server and the @ptitude Observer Monitor computer must use DBCS. DBCS is the character set used by Korean, Chinese, Japanese Windows, etc.

Internal OPC Server

To configure the built-in OPC Server in Observer:

- Click **On-line** on the toolbar, then select **OPC Servers** and select to configure **Internal OPC Server**.

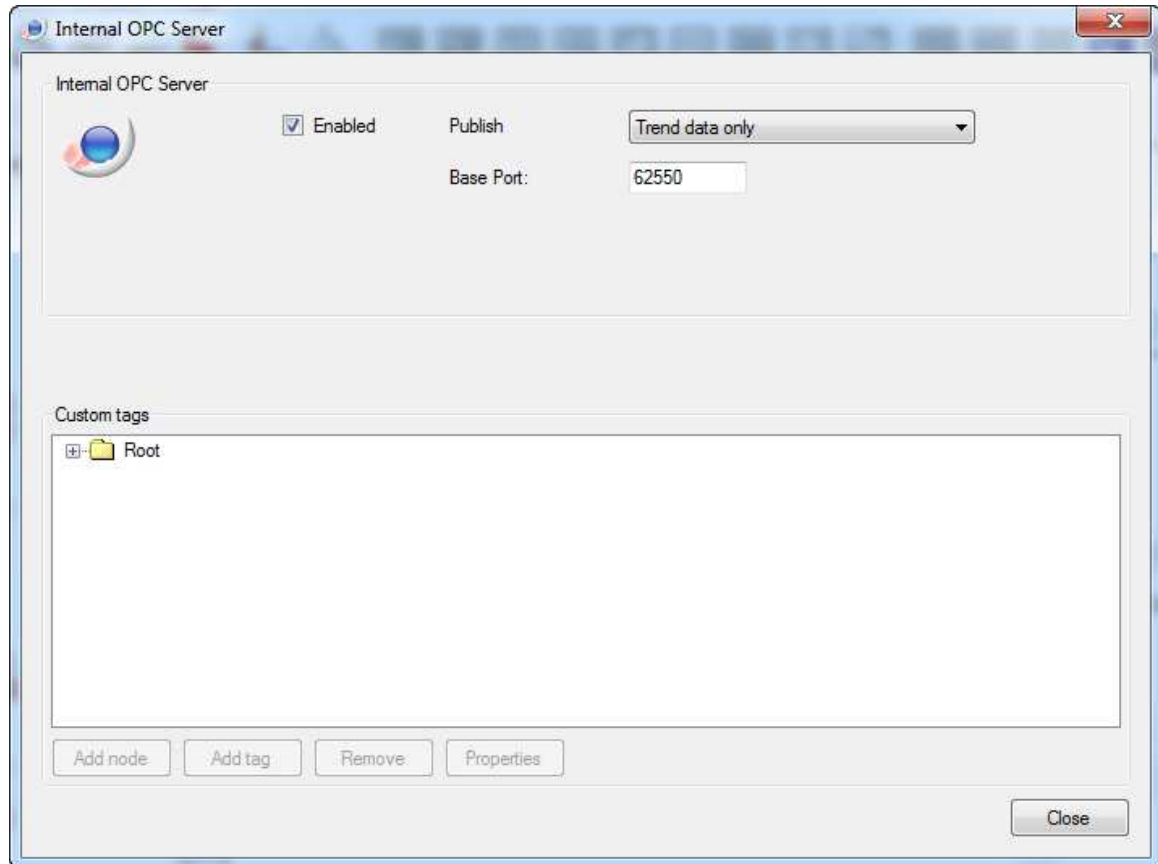

Figure 4 - 37.
Example of Internal OPC Server.

When enabled, the Internal OPC Server will automatically publish the latest measurement for all measurement points that have been captured with the @ptitude Observer system, in addition it is also possible to configure custom tags that can be used. The custom tags can be used by other OPC Clients to communicate data to and from the server but the Observer system will not modify or use the data of these tags.

Enabled indicates the status of the OPC server whether it is enabled or disabled.

Publish selects which type of data that should be published. The option is to publish trend data or trend data and dynamic data. Dynamic data is FFT, Time waveform etc.

Base port defines the base communication port for the internal OPC Server.

The default setting is 62 550. If it is set to the default it will use the base port and the base port plus 1 when the Internal OPC Server starts. Which means that the Internal OPC Server will communicate on port 62 550 and 62 551.

Usually the base port does not need to be changed unless (on the same computer) ports 62 550 or 62 551 are in use by another application or there are multiple monitor services with the OPC Server enabled.

Add node adds a folder to the custom tag hierarchy.

Add tag adds a custom tag to the custom tag hierarchy.

Remove removes the custom selected tag or the selected folder.

Properties brings up the configuration for the custom selected tag or the selected folder

External OPC Servers

To configure external OPC Servers in Observer:

- Click **On-line** on the toolbar, then select **OPC Servers** and select to configure **External OPC Servers**.

To add an OPC Server:

- Click **Add** in the OPC Servers window.

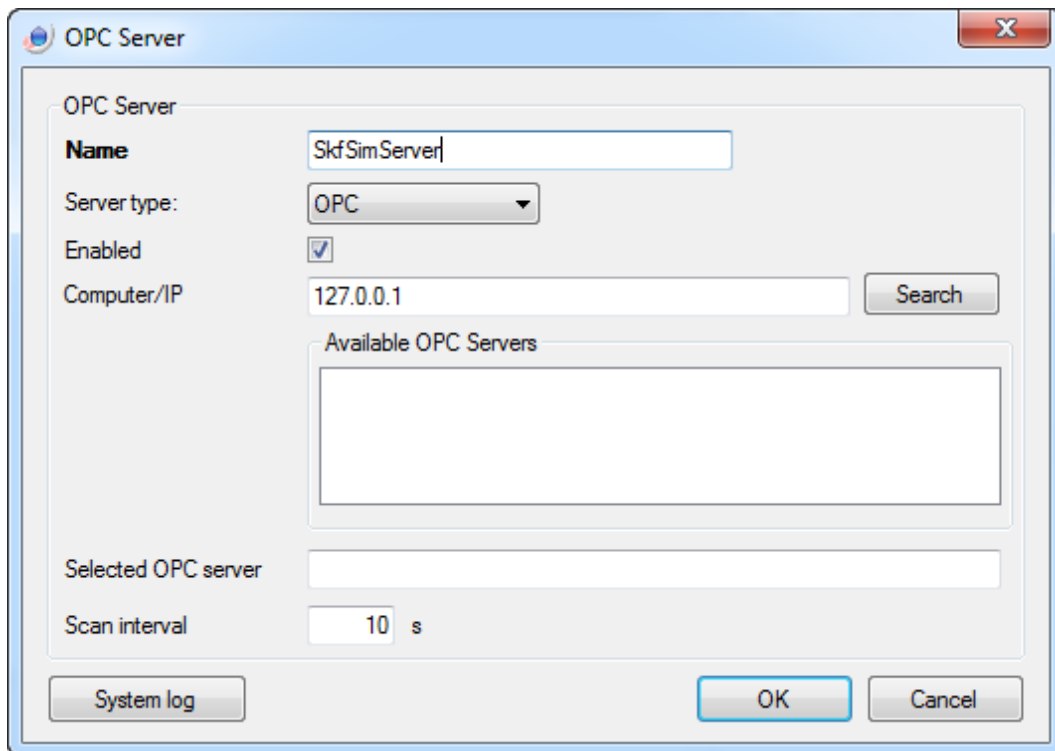

Figure 4 - 38.
Example of Add an OPC Server.

Name is the name for this OPC server registration.

Server type specifies whether this server is an OPC or OPC UA server.

Enabled indicates the status of the OPC server whether it is enabled or disabled.

Computer/IP is the computer name or IP number for which the OPC server is located.

Search returns a list of the (available) OPC servers at the specified IP address.

Available OPC Servers lists the OPC Servers found when clicking the "Search" button.

Selected OPC server is the pre-defined name of the OPC server being used. This is not editable.

Scan interval is the scan time interval in seconds. The @ptitude Observer Monitor uses it to scan the OPC server for current values. Default is 10 seconds which means that the @ptitude Observer Monitor checks for the current values of the OPC server every ten seconds.

System log is a configuration log containing all the setup activities which can be useful when investigating or tracking changes made during the setup.

To edit an OPC Server:

- Click **Edit** in the OPC servers window. The settings available for editing an OPC server are the same as in Adding an OPC Server from above.

To remove an OPC Server:

- Select an OPC server from the list of OPC servers
- Click **Remove** in the OPC servers window to remove the OPC server from the list.

To create OPC Channels:

- Select an OPC server to use, from the list of OPC servers.
- Click **Add** in OPC channels window.

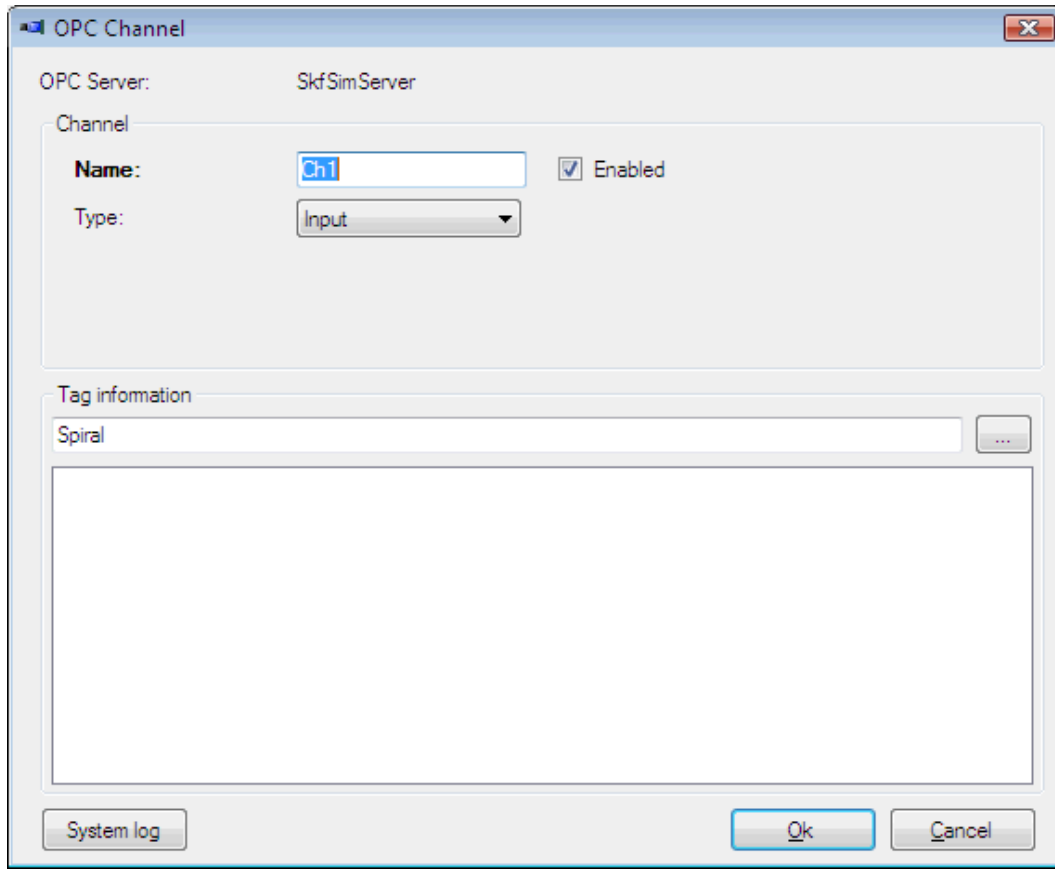

Figure 4 - 39.
Example of Create an OPC Channel.

OPC Server is the name of the OPC server selected in the previous screen. This value is not editable.

Channel name is a name for this OPC channel.

Enabled indicates the status of the channel whether it is enabled or disabled.

Type

Input: a channel that sends data from an OPC server to @ptitude Observer.

Output: a channel that sends data from the @ptitude Observer to an OPC server and subsequently to another system.

Source specifies which measurement point to retrieve data values from @ptitude Observer and send data to the OPC server. It is available only when the type is set to Output.

Data type is available only when the type is set to Output.

Overall: sends the overall value to the OPC tag on the OPC server.

Status: (advanced) sends the bitwise internal status of the measurement point to the OPC tag on the OPC server.

Tag selects the unique tag name to be used. Note that tags must be created in the OPC server itself. For further information on how to create tags, refer to the OPC server manual.

Once OPC input channels have been created, the next step is to create OPC measurement points for them. To do this, refer to [Setting up Measurement Points and Alarms](#) in System Configuration.

The most common problem when troubleshooting connections to OPC servers is the security. OPC makes use of DCOM which can be quite difficult to configure for those unfamiliar with it. Request assistance from IT-personnel when setting up the OPC configuration.















OPC Server Status Tag Value







Each OPC server status tag displays its status icon along with its numeric value.

When multiple states exist on a measurement point at the same time, the icon of the most priority will be displayed. The priority list of status for measurement points is listed in [Priority List of Status](#) under Tree View in System Operation chapter.

As an example, if Vector Alarm and Trend Alarms are active at the same time,

then the Alarm icon, , will be showing along with the numeric value of **8449**.
 $8449 = 1 \text{ (Ok)} + 256 \text{ (Trend Alarm)} + 8192 \text{ (Vector Alarm)}$

Icon	Numeric Value	Description
	0	Unknown. Refer to Unknown in Status in the Hierarchy View section
	1	Ok. Refer to Ok in Status in the Hierarchy View section
	2	Not measured. Refer to Not measured in Status in the Hierarchy View section
	4	Protean decrease. Refer to Protean in Status in the Hierarchy View section
	8	Protean increase. Refer to Protean in Status in the Hierarchy View section
	64	Low Warning active. Refer to Warning in Status in the Hierarchy View section
	128	High Warning active. Refer to Warning in Status in the Hierarchy View section
	256	High Alarm active. Refer to Alarm in Status in the Hierarchy View section
	512	Low Alarm active. Refer to Alarm in Status in the Hierarchy View section
	1024	Outside measurement range. Refer to Outside active range in Status in the Hierarchy View section
	2048	Cable fault. Refer to Cable fault in Status in the Hierarchy View section
	4096	Not active. Refer to Not active in Status in the Hierarchy View section
	8192	Vector Alarm active. Refer to Alarm in Status in the Hierarchy View section
	16384	Vector Warning active. Refer to Warning in Status in the Hierarchy View section

Icon	Numeric Value	Description
	262133	Pre/Post data capture in progress
	1048576	Trip in progress
	8388608	Relation Alarm active. Refer to Alarm in Status in the Hierarchy View section
	33554432	Diagnosis warning. Refer to Diagnosis warning in Status in the Hierarchy View section
	67108864	Diagnosis alarm. Refer to Diagnosis alarm in Status in the Hierarchy View section
	134217728	No Trend Alarm levels set. Refer to No alarm levels set in Status in the Hierarchy View section
	268435456	Outside active range unstable. Refer to Outside active range unstable in Status in the Hierarchy View section
	536870912	Transient. Refer to Transient in Status in the Hierarchy View section
	1073741824	Outside active range. Refer to Outside active range in Status in the Hierarchy View section

Setting up Measurement Points and Alarms

A user can add new measurement points and edit or delete existing measurement points on machines and sub machines.

To add a measurement point:

- First, select a machine or a sub machine to which a measurement point is to be added in the hierarchy view.
- Click on the right mouse button, select **Add**, then select **Meas. point**.

To edit a measurement point:

- First select a measurement point to be edited in the hierarchy view.
- Perform one of the following options.
 - Click on the right mouse button and then select **Properties**.
 - Double click on the measurement point.
 - Click on **Edit** on the toolbar and then select **Properties**.
 - Click on  Properties icon on the toolbar.

To delete a measurement point:

- First, select a measurement point to be deleted from the hierarchy view.
- Click on the right mouse button, then select **Delete**.
 - If the point being deleted is referenced by a Multiple Gating Point, the system will remove that reference.

It is also possible to use one of the following wizards to help with the add and edit, measurement point processes:

Machine copy wizard. Refer to [Machine Copy Wizard](#) in System Configuration.

Multiple point update wizard. Refer to [Multiple Point Update Wizard](#) in System Configuration.

Measurement Points

Different types of measurement points are available depending on the selected device. The following figure is an example of measurement points available for an IMx device in @ptitude Observer.

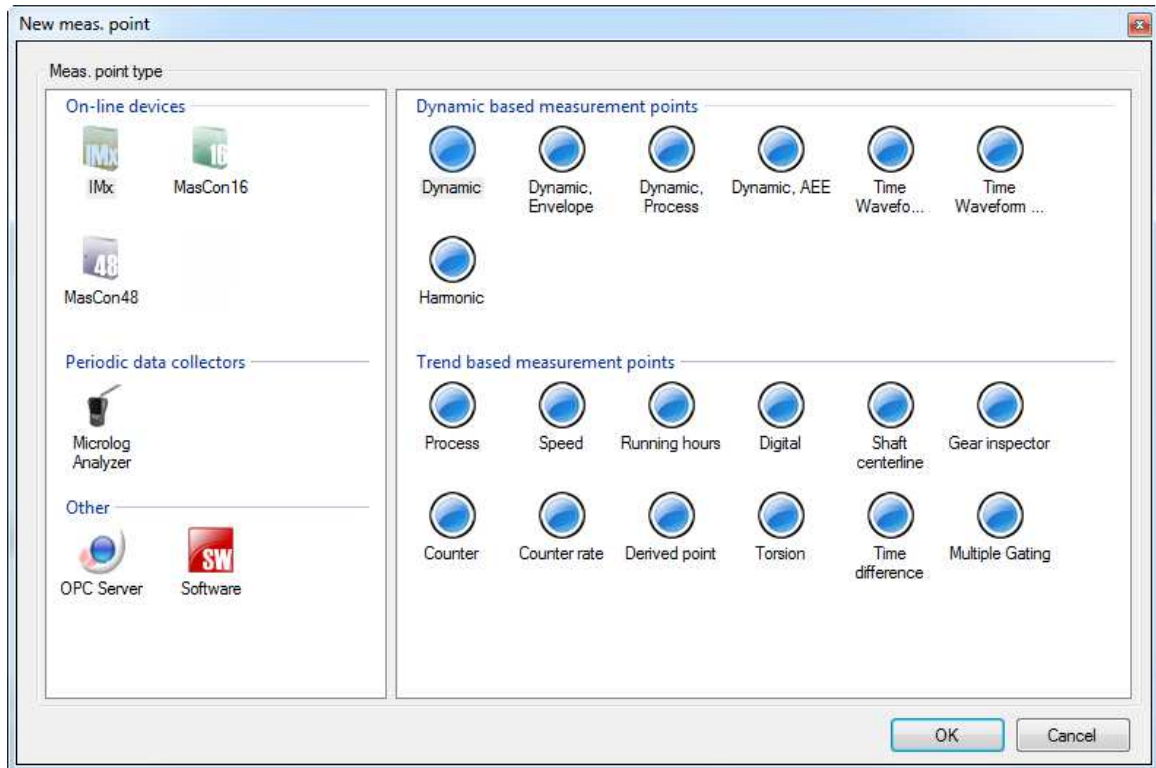

Figure 4 - 40.
Example of New Measurement Point Types.

Dynamic based measurement points – Select one of the following measurement point types to create a measurement point that will ultimately produce spectrum and/or time waveform graphs.

Dynamic is a measurement of a dynamic signal such as vibration sensors, AC current or any other dynamic signal that could change at a frequency faster than 0,1 Hz.

Dynamic, Envelope is a measurement of repetitive frequencies. It is used to detect and monitor repetitive frequencies, such as bearing failure detection and monitoring.

Dynamic, Process is similar to a Dynamic measurement point, but instead of a vibration signal, it uses an analogue sensor for the measurement. For example, it can be used for motor current analysis.

Dynamic, AEE is a measurement of an acoustic emission signal.

Time Waveform Analysis is a measurement of the time waveform and applies algorithms such as crest factor, kurtosis and skewness to detect failures.

Time Waveform Analysis, AEE is same as Time Waveform Analysis but used for acoustic emission signal.

Harmonic is a measurement of a dynamic signal with vibration sensors or Eddy Current Probes such as vibration monitoring on turbines.

SEE[®] (spectral emitted energy) is designed especially for measuring high frequencies for Microlog CMVA series only. It requires a special sensor kit.

Trend based measurement points – Select one of the following measurement point types to create a measurement point that will ultimately produce trend graphs.

Process is a measurement of a static/process signal such as load sensors, temperature sensors, pressure, flow or any other static signal.

Speed is a measurement of the rotational speed of a shaft. It is used to measure rotational speed of a shaft with a speed sensor.

Running hours is a measurement point for IMx/MasCon devices. It provides an effective usage for Observer's [Maintenance Planner](#) feature. It keeps track of running hours of a machine.

Digital is a measurement of an input that reacts like a digital signal for IMx/MasCon48 devices. This means that the input signal basically has only two states: a digital 1 and a digital 0 or relay closed and relay opened. A digital measurement point can be used to control when to take trend vibration data and when to take spectrum data.

Shaft centerline is a measurement that uses information from two radial displacement sensors located in the same axial position 60 to 120 degrees from each other in IMx devices.

Gear inspector is useful when analysing impact energy as a function of shaft/gear revolutions in wind turbines.

Counter is a measurement that counts digital pulse changes which produces a value with the total amount of digital value changes. It can be reset and the value will start from zero again. It is currently available for IMx/MasCon16 devices only.

Counter rate creates a new measurement that counts pulses per second, minute, hour, day or week on a digital channel. This measurement point can be used to measure a particle counter.

Derived point is a calculation measurement point which does not use any sensor in IMx/MasCon16 devices. Instead, it takes other measurement points to calculate the result to trend.

Torsion is a measurement of the torsion of a shaft using two digital channels for IMx/MasCon48 devices.

Time difference is a measurement of the time difference between two digital pulses of IMx/MasCon48 devices.

Multiple Gating, Process is a measurement that references values from up to five other points and then performs a logical evaluation on the current measurements to determine if the IMx should take measurements. Each reference point has two distinct gating conditions, Operating Class 1 or Operating Class 2, with the point output determined by which set of the two gating conditions is set to TRUE. These reference measurements can include process, speed and digital measurements.

HFD (High Frequency Domain) is a type of vibration measurement like an envelope measurement. It produces only an overall value and is used only for the Microlog Analyzer.

OPC is a measurement that is used when the system requires data from an external system with the help of an OPC Server.

- Before starting the configuration of an OPC measurement point, make sure to complete the setup for OPC server and OPC channels. If not, refer to Creating OPC Server and OPC Channels in System Configuration.

Data tagging is used to track down material related or characteristic related data. Measurements can be marked with a specific tag such as paper quality, motor brand, revision number or any other property of a machine. Data can be tagged manually with Software data tagging point or automatically by OPC data tagging points.

Speed from spectra is a manual speed measurement point with static value.

Derived is a general measurement point that is also called @ptitude Observer derived measurement point. A derived measurement is a calculation point that uses other measurement points to calculate what to trend. For example, it could be used to trend the sum of all vibrations of a machine or the average efficiency of four different turbines. The @ptitude Observer derived measurement can take data from IMx/MasCon and OPC measurement points. The measurement value is calculated in the @ptitude Observer Monitor every 10 seconds.

General Tab

On the **General** tab, the general attributes required to create various measurement points can be configured. Different settings are available for different device types and different attributes are available for different measurement point types. The following is an example of the **General** tab as it appears for an IMx dynamic vibration measurement point.

System Configuration Setting up Measurement Points and Alarms

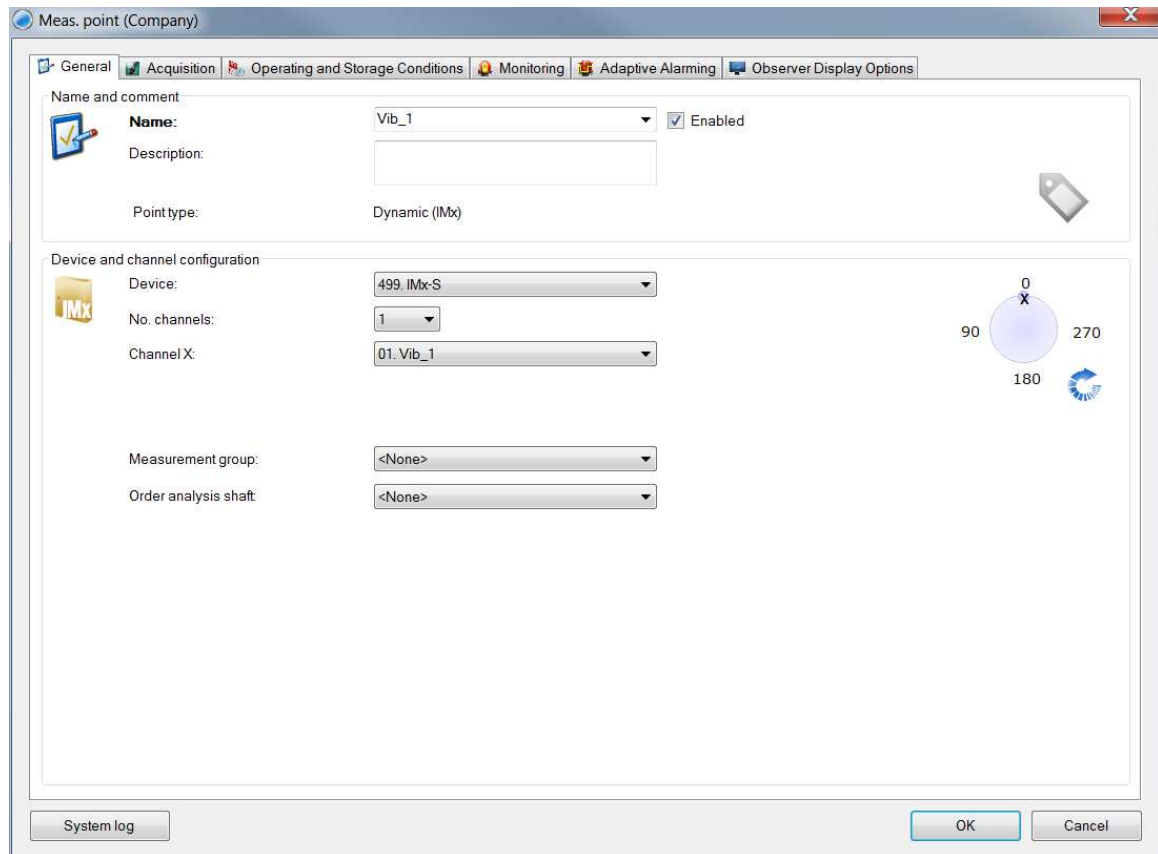

Figure 4 - 41.
Example of Dynamic Measurement Point General Settings.

The **General** tab can contain any of the following elements, depending on the device type and measurement point type being configured:

Name and comment area

Name is a short description of the measurement point. All names are saved and can be used by other measurement points if desired.

Enabled indicates the status of the measurement point whether it is enabled or disabled.

- The maximum active measurement points per 16 channel device is 100 points.
- The maximum active vibration measurement points per 16 channel device is 80 points.

Description is any additional comments for the current measurement point.

Point Type is the measurement point selected along with the device type.

MPA code is for Microlog Analyzer USB and 1-channel communication only. It is used to group measurement points together.

Sensor type is for Microlog Analyzer only. It can be accelerometer, displacement probe or velocity sensor. Note that once the sensor type has been set, it cannot be changed.

No. of directions is for Microlog Analyzer only.

- Use TriAx sensor allows the use of a tri-axial sensor when measuring single axis measurement points. Select which axis to use for the point.

Orientation is a suitable sensor orientation.

Meas. interval is for Microlog Analyzer only. It is the measurement interval that the point should be measured by personnel. If this time is exceeded the system will generate an alarm.

Evaluation time tells the tolerance time when calculating a value depending on parameters. An evaluation time of 5 minutes means that the parameter values collected from IMx/MasCon or OPC should be maximum 5 minutes old.

Device and channel configuration area

Device is an IMx/MasCon device in which the measurement point can be set up.

MasCon/IMx unit (for Multiple Gating Points only) is the MasCon/IMx unit a Multiple Gating Point will reference.

No. channels is used by the selected measurement point, for example, for vibration, envelope, harmonic, process FFT, process and speed measurement points.

- Multiple Gating Points (related to Dynamic and Dynamic Envelope points only), cannot be used with multiple channel points.

Channel (Channel X / Channel Y / Channel 1) is the channel in which the measurement point should be performed. Multiple channels can be selected. However, for shaft centerline, torsion and time difference measurement points, two different channels must be selected. Note that speed channels must be configured in IMx/MasCon units before they can be selected here.

Trigg channel is the trigger channel which can be used for phase measurement and torsion measurement points. A channel having more than one pulse per revolution cannot be used. Note that a trigger channel must be selected for condition monitoring on turbines.

Measurement group is a logical grouping of measurement points that should collect data at the same time and synchronously on a specific IMx/MasCon device. Setting up measurement groups is described in [Measurement Groups](#) under Database in Menu Items

Order analysis shaft is the shaft on the machine that should be used for order analysis in the spectrum, history and 3D plot.

Rotation direction indicates the rotational direction for vibration measurement points, clockwise, counter-clockwise or both.

Cable check is an alternate source for the cable check since the channel of this measurement point does not have the option to verify a status of the bias.

OPC Server and channel settings area (for OPC measurement points only)

Note that to send data from @ptitude Observer to an OPC server, a setup of an OPC measurement point is not required. Instead, this is completed through OPC channel setup.

OPC server is a pre-configured OPC server to be used for this measurement point.

OPC channel is the channel to connect to.

DAD is required for OPC server.

Channel is a channel to be connected.

Data tagging group allows a data tagging group to be selected from the drop-down list. Data tagging groups are created through the [Data tagging group](#) interface under Library\Database in Menu Items.

Source area (for Software, Data tagging measurement points only)

Data tagging group allows a data tagging group to be selected from the drop-down list. Data tagging groups are created through the [Data tagging group](#) interface under Library\Database in Menu Items.

System log is a configuration log of all the changes made to the measurement point.

Acquisition Tab

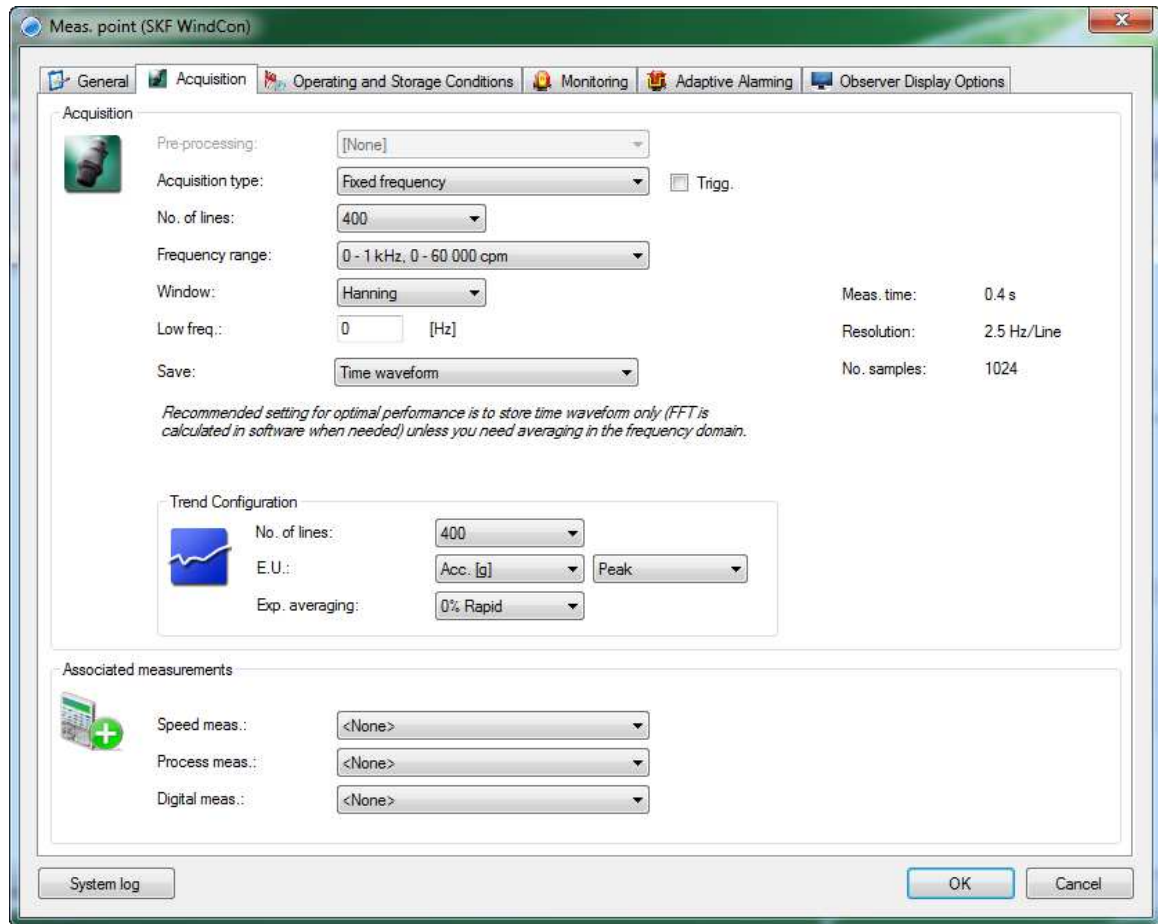

Figure 4 - 42.
Example of Dynamic Measurement Point Acquisition Settings.

The **Acquisition** tab can contain any of the following elements:

Acquisition area

Pre-processing is a pre-processing type, such as Envelope.

Acquisition type can be Fixed frequency or Order Tracking.

Fixed frequency: Sets acquisition to take the point's measurements on a fixed frequency machine.

Order Tracking: Sets acquisition to utilise order tracking while taking the point's measurements on a variable frequency machine. When selected, information appears on the right of the screen indicating the order analysis shaft, as selected on the **General** tab and its order of running speed, as determined from the gear ratios calculated in the Machine Parts view.

Trigg indicates if the selected speed measurement should be used as the trigger for the measurement point. If trigger is set, then the phase information will be available for the measurement.

- 'Trigg' will be automatically set if Acquisition Type is set to Order Tracking.

No. of lines is the number of lines needed to construct the FFT (Fast Fourier Transform).

Frequency range is the maximum frequency for the FFT or time waveform. Select a frequency range from the drop-down list or choose Custom option to enter the end frequency in Hz. The end frequency can be between 5 and 40 000 Hz in integer numbers only.

Window is the window type for the FFT which can be Hanning or Uniform.

Low freq is the low frequency cut-off which can be used as a filter to limit unwanted peaks or "ski slopes" at the start of the FFT. For example, setting this value to 5 will zero out all values between 0 and 5 Hz in the FFT.

Save determines which format of the captured data should be stored in the system. Storing time waveform only is the recommended setting. Observer will on the fly calculate and display the FFT based on the time waveform when clicking the spectra button.

Meas. time describes the current measurement time calculated with the currently selected number of lines and frequency range.

Resolution describes the current resolution calculated with the currently selected frequency range and number of lines.

No. samples is the number of samples needed to construct the time waveform.

Shaft 1 shows the calculated orders of running speed compared to the designated order analysis shaft.

Sampling revolutions indicate how many revolutions the trend value should be based on for shaft centerline measurements only.

Max time is the time allowed for measuring a trend value for shaft centerline measurements only. If it takes longer time than the specified time to measure the desired sampling revolutions, the trend value will still be calculated and stored.

Formula area

Parameters are used by the formula for derived point measurements. There are two types of parameters, Constant and Trend.

Constant: this value never changes. It can be custom created here by assigning parameter's name, setting the type to Constant and assigning any numeric value.

Trend: another measurement point value in the system. It can also be custom created here by assigning a name, setting the type to Trend and selecting a measurement point from the system as the source. The source selected here must be from the same IMx/MasCon device.

Formula is the calculation formula using the assigned parameters from above for derived point measurement. The normal calculation methods [+ , - , * , / , ^ , (,)] and mathematical functions are available to build a formula.

Check verifies if @ptitude Observer and @ptitude Observer Monitor can understand the formula entered. An automatic verification is performed, on clicking **Ok** as well.

Trend Configuration area

No. of lines is the number of lines needed to construct the FFT (Fast Fourier Transform).

E.U. (Engineering Unit) is the engineering unit in which this measurement is to be displayed. If the scale factor is set to 1, then E.U. will be set to degrees. However, if the measurement point is a counter rate, this acts as a user editable text field. See **Time Unit**, below.

Scale factor is used to set a different scale factor than the engineering unit (E.U.) of degrees. The default is 1.

Time unit is available for counter rate measurement points only. It can be pulses of seconds, minutes, hours, days or weeks. Note that for counter rate measurement points, **E.U.** is a user entered text that will be displayed on graph only. Which means that it will not affect the measurement at all. The text should reflect the selected time unit, for example if time unit is selected as Seconds, E.U. should be changed to Pulses/second.

Resettable sets whether the measurement point's value can be set to zero or not. It is available for count measurement points only.

Unit is the unit on which the trend measurement should be performed.

Scaling defines how the trend values should be calculated and stored in the database.

Counter type sets the calculation method that should be used for this counter measurement point.

Pulses: The value collected is added to the previous value. This is a normal counter.

Stops: Each time a value is collected, the previous value is incremented by one (1).

Pulses between stops: The value collected is the value used. This can be used, for example measuring the distance between two train stations if an IMx has been fitted on a train.

Exp. averaging (exponential averaging) is a setting to perform an automatic trend curve smoothing or to stop the system from giving alarms when intermittent disturbances occur. The function applies the following formula:

$$\text{new calculated} = \text{measured} * (1 - \text{exp value}) + \text{last calculated} * \text{exp value}$$

Compensate for speed is available for "running hours" measurement points only. It compensates the running speed of a machine by comparing the active speed of the machine against a nominal speed of the machine. The **Nominal speed** of the machine is entered by the user.

For example, if the active speed of the machine is 1 000 cpm and the nominal speed is set to 2 000 cpm, then after the machine has been run for two hours, because of the difference between the active speed and the nominal speed, the running hours value will be one hour instead of two hours.

Compensate for load is available for "Running hours" measurement points only. It enables a compensation for the active load or any other process signal compared to a **Nominal load** value entered by the user. Compensate for load works the same way as Compensate for speed.

Spectra source is the measurement point where that maximum amplitude is being searched to get the speed reading.

Min. speed / Max. speed is the start and stop search range of the spectra source.

Machine part can be a gear or a shaft that helps to get more precise speed reading by using its fault frequency.

Speed is the running speed in rpm (revolution per minute).

Deviation is the percentage the speed can vary during the measurement of the machine. This is used in the diagnosis calculation when obtaining the fault frequencies. It sets the search range of frequencies for the diagnosis calculation.

Deviation time tells the tolerance time when calculating a value depending on parameters. A deviation time of 5 minutes means that the parameter values collected from IMx/MasCon or OPC should be a maximum of 5 minutes old.

Associated Measurements area

Speed meas. is a speed measurement point to which the currently selected measurement point should be connected/linked. The selected speed measurement point will be taken with the current measurement point's data.

- If 'Trigg' has been checked (manually or because of order tracking), speed channels from Modbus (external channels) will be unavailable for selection as an actual tachometer signal (pulse train) is required.

Speed controlled sampling indicates whether to use speed controlled sampling or not. If it is checked, then all the samples during one revolution of the shaft will be used to calculate the average position of the shaft. If unchecked, then the samples during 0,1 second will be used to calculate the average position of the shaft. It is used to get a better reading of the shaft position. Therefore, for measuring the shaft position it is strongly recommended to enable this field.

Process meas. is a process measurement point to which the current measurement point should be connected/linked. The selected process measurement point will be taken with the current measurement point's data.

Digital meas. is a digital or Multiple Gating measurement point to which the current measurement point should be connected/linked. The selected digital or Multiple Gating measurement point will be taken with the current measurement point's data.

If the current measurement point is a Dynamic or Dynamic Envelope point, then all Multiple Gating Points assigned to the same IMx as the current point appear in the **Digital meas.** drop-down list.

- To successfully set up the current measurement point to be referenced by a Multiple Gating Point, the **No. channels** value on the **General** tab must equal **1**.

Settings area (for Microlog Analyzer only)

E.U. is the engineering unit in which this measurement is to be displayed.

Scaling is used to change the display scaling (detection) of the measurement.

Pulses/rev. is the number of pulses the device receives per shaft revolution.

Full scale is used to scale the values.

Full scale, Env. is used to scale the values for Envelope.

Full scale, Veloc. is used to scale the values for Velocity.

Full scale, Temp. is used to scale the values for Temperature.

Zero level is the value that should be equal to zero in the measurement unit.

Sensitivity specifies the sensor sensitivity.

Envelope filter is a pre-processing type such as Envelope, for example.

ICP current feed indicates whether the sensor is to be powered or not.

Frequency type can be Fixed freq. range or Order tracking.

No. of lines is for the FFT taken for extracting trend values.

Save specifies what kind of data that should be collected and stored. Choose between FFT, Time waveform or both. Data called FFT and Phase are also available for order tracking.

Window can be Uniform, Hanning or Flattop.

Speed sets a static speed value that will be stored with the measurement.

End freq. is the highest frequency that should be measured.

Low freq. is the lowest frequency that should be measured.

No. of averages is the number of measurements the Microlog Analyzer should measure to get the average reading by combining all measurements. However, this number is ignored if the averaging is Off.

Averaging is a type of averaging method which the system should perform on the data before it is stored to the database.

Speed meas. point selects a speed measurement point whose value will be measured and stored as the speed for this measurement point. This overrides the static speed setting.

Order analysis shaft is the shaft on the machine that should be used for order analysis in the spectrum, history and 3D plot.

General Settings area (for Multiple Gating Points only)

Use – Select whether the MGP will base its evaluation on one or two operating classifications (classes). When Both Classes is selected, two different gate ranges can be set for each of the five reference points (on the **Class 1 gating** and **Class 2 gating** sub-tabs). When Single Class is selected, a single gate range can be set for each of the five reference points (on the **Class 1 gating** sub-tab).

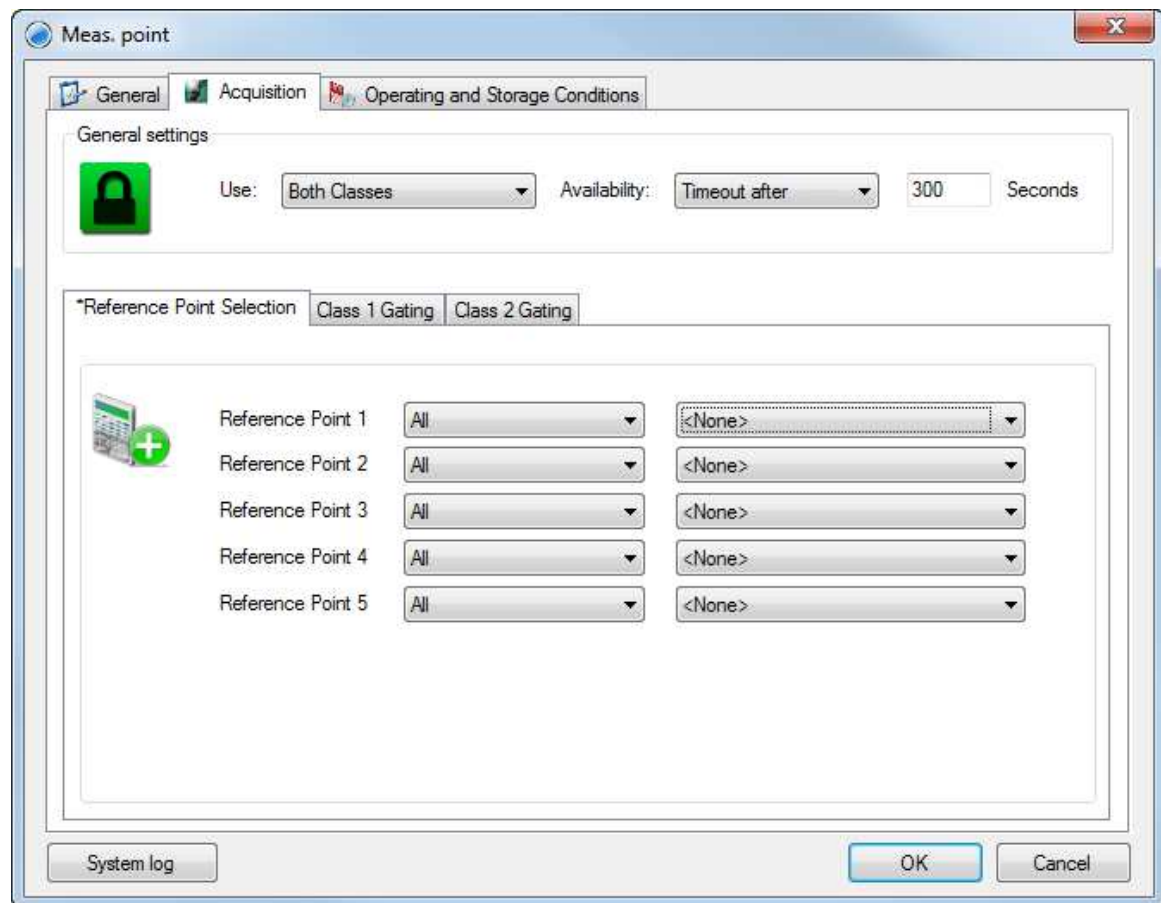

Figure 4 - 43.
Example of Multiple Gating Point, Reference Point Selection.

Availability – Select if and how gating should be suspended if one of the required reference points becomes unavailable:

Timeout after: Select to have the system suspend gating until a specified time period has elapsed. Enter that period (in seconds). The default is 300 seconds.

Timeout disabled: Select to have the system continue gating.

On next evaluation: Select to have the system suspend gating until the next measurement.

Reference Point Selection sub-tab (for Multiple Gating Points only)

Reference Point 1 through **5**: Select up to five points from the selected IMx unit for the Multiple Gating Point to reference.

From each left drop-down list button, select a point type to reference from the IMx: All, Process, Digital or Speed

From the right drop-down list button in the same row, select a measurement point to reference from the IMx. Options in this drop-down are filtered based on the target point type selected.

Class 1 gating and **Class 2 gating** sub-tabs (for Multiple Gating Points only) are enabled for each operating classification set up on the Options dialog's Data tab (one or two classes only).

Settling Time – Enter the number of seconds, upon entering a cable fault alarm status, for which Observer will remain in this status once sensor power is restored, given the applicable operating class. The class's gating output is enabled only when all required conditions have been met for this period. The default is 1 second.

Reference Point 1 through **5** sub-tabs display the measurements selected (on the Reference Point Selection sub-tab) for each reference point. These sub-tabs are enabled for assigned reference points only.

Absolute condition: The gating parameter range. Select (check) the **Min** checkbox and then enter a value to set a minimum **Absolute condition**. Select (check) the **Max** checkbox and then enter a value to set a maximum **Absolute condition**.

Delta condition: The accepted range, during measurement, of gating parameter change. Use this setting to force the system to take data when the operating mode of the machine is stable, thus ensuring capture of accurate and trustworthy data. Select (check) the **Min** checkbox and then enter a value to set a minimum **Delta condition** (permitted change). Select (check) the **Max** checkbox and then enter a value to set a maximum **Delta condition** (permitted change).

Period: Amount of time, in seconds (up to 60), for which the system must check the **Delta Condition** thresholds.

<p>Important - One or more of the reference point gating ranges (conditions) must be different between two classes.</p>
--

System log is a configuration log of all the changes made to the measurement point.

Operating and Storage Conditions Tab

On the **Operating and Storage Conditions** tab, the user can configure when the measurement should be taken.

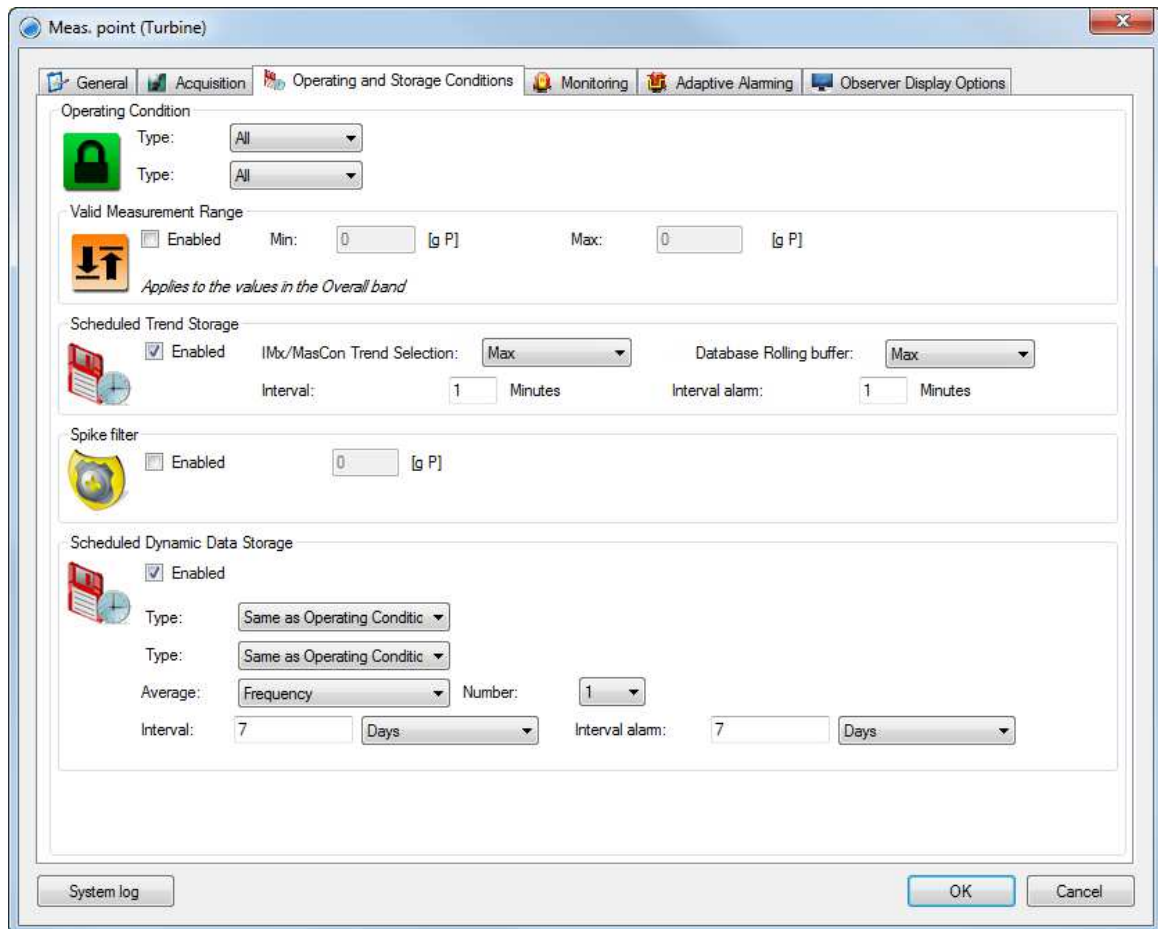

Figure 4 - 44.
Example of Dynamic Measurement Point Operating and Storage Condition Settings.

The **Operating and Storage Conditions** tab can contain any of the following elements:

Operating Conditions area

Operating condition is calculated with the help of the measurement points specified in the [Associated Measurements](#) of the **Acquisition** tab settings. For example, if speed is selected as an active range type, a speed measurement point must be selected in the Associated measurements section as well.

Important - The specified conditions must be met for the measurement point to collect and store data in the database. The assigned conditions must be met before the system raises any alarms. If both conditions are specified, both conditions must be met before the system raises any alarms.

Type is the type of gating which can be set to one of the following values:

All: means that the active range check is disabled. In other words, the active range that the measurement point is using is all values.

Speed: means that the active range check is determined by the speed measurement point readings selected in the [Associated Measurements](#) of the **Acquisition** tab settings.

Process: means that the active range check is determined by the process measurement point readings selected in the [Associated Measurements](#) of the **Acquisition** tab settings.

Digital: means that the active range check is determined by the digital measurement point readings selected in the [Associated Measurements](#) of the **Acquisition** tab settings.

Condition is the gating parameter range with minimum and maximum values.

- (For Dynamic and Dynamic Envelope points only) If the **Type** selected is Digital and the **Digital Measurement** selected on the **Acquisition** tab is a Multiple Gating Point, then this drop-down list box will allow the user to select one or both of the operating classes established for that Multiple Gating Point. Once one or both of the operating classes have been selected, the **Enable class dependent alarms** checkbox on the **Monitoring** tab becomes enabled but remains deselected (unchecked) by default.

Max allowed delta is the maximum accepted change of the gating parameter during the measurement. Use this setting to force the system to take data when the operating mode of the machine is stable which may be the only way to capture the accurate and trustworthy data.

This is an important setting when performing a process measurement point on variable speed machines. This is not important for a speed measurement point. It depends on the application. For example, for measuring bearing temperature, this function can be deactivated by setting it to 0.

Valid Measurement Range area

The system can be forced to take data only when the amplitude reading is at a certain level, by assigning a minimum and a maximum value of the measurement range. If the measured value is outside the measurement range, then the system alarm will be generated instead of an alarm on the measurement point.

System alarms are displayed in the system view or system alarm window from the icon bar, instead of in the alarm list. For example, if the range is set to 0 to 300 °C and the temperature sensor output is above 300 °C, then this value will be treated as an unrealistic value and the IMx/MasCon system will generate a system alarm in the system alarm list instead of in the alarm list. The cause of this alarm could be a bad earth connection or surrounding interference that disturbs the output signal from the sensor.

Enabled is the status of this measurement range, enabled or disabled.

Min. is the minimum value of the measurement range.

Max. is the maximum value of the measurement range.

Scheduled Trend Storage area

Enabled box allows the Scheduled Trend Storage function to be enabled or disabled.

IMx/MasCon Trend Selection defines which measured values to keep during the storage **Interval** (as the device is constantly measuring during the time period set for the interval).

Max: Keeps the maximum value for the entire storage interval period.

Min: Keeps the minimum value for the entire storage interval period.

First: Keeps the first value measured in the storage interval period.

Database Rolling buffer determines which trend value to keep as data is being thinned out by the rolling buffer feature in the monitor service.

Max: Keeps the maximum value for the time period.

Min: Keeps the minimum value for the time period.

First: Keeps the first value for the time period.

Interval is the desired interval for data capturing which depends on the application.

The selection made here affects how fast data should be moved from short term buffers to long term buffers in the database.

There are four different buffers in the @ptitude Observer database, a minute buffer, an hour buffer, a day buffer and a week buffer.

In each buffer 3 000 values can be stored as default. For example, if the measurement interval is set to 1 minute, the length of the minute buffer will be 3 000 minutes (50 hours). As more data comes in, values are moved to the hour buffer. For a specific hour, all values in the minute buffer are analysed and the system will move one of the values during this time period to the hour buffer. This logic works similarly for the hour to day buffer and so on. The default of 3 000 values for each buffer can be configured in the @ptitude Observer Monitor service.

The type of the value to be moved from one buffer to the next is determined by the **Database Rolling buffer** field in the Scheduled Trend Storage, above.

Interval alarm is the desired interval for data capturing when the level is in warning or alarm condition.

Exception based storage settings are only shown for trend based measurement points.

Save (Delta) checkbox – Select (check) to set the system to capture and store measurement trend data whenever there is a change in condition.

- To disable interval based trend storage, enter a zero in the **Interval** text box.

Spike filter area

Enabled box allows the Spike filter function, to be enabled or disabled.

The spike filter is useful to avoid alarming on high peak readings that could be picked up by the sensors caused by other sources rather than the machine itself. These measurements are not the ones that should raise alarms and should not be stored in the database either. For example, setting this value to 20 m/s² will set the system to ignore any measurements above this level completely. However, when the system detects high peak reading,

the measurement will display the status of "Outside measurement range"



, indicating that the values coming from this measurement point are outside of the acceptance range.

Scheduled Dynamic Data Storage area

Enabled box allows the Scheduled Dynamic Data Storage function to be enabled or disabled.

Dynamic Data Storage is calculated with the help of the measurement points specified in the [Associated Measurements](#) of the **Acquisition** tab settings. For example, if speed is selected as an active range type, a speed measurement point must be selected in the Associated measurements section as well.

Important - The following specified conditions must be met for the measurement point to collect and store data in the database. The assigned conditions must be met before the system raises any alarms.

Type is the type of gating which can be set to one of the following values:

Same as Operating Condition: configures the dynamic data storage range to be same as the Operating Condition range.

Speed: means that the dynamic data storage range check is determined by the speed measurement point readings selected in the [Associated Measurements](#) of the **Acquisition** tab settings.

Process: means that the dynamic data storage range check is determined by the process measurement point readings selected in the [Associated Measurements](#) of the **Acquisition** tab settings.

Digital: means that the dynamic data storage range check is determined by the digital measurement point readings selected in the [Associated Measurements](#) of the **Acquisition** tab settings.

- (For Dynamic and Dynamic Envelope points only) If the **Digital measurement** point selected in the Associated measurements section of the Acquisition tab is a Multiple Gating Point, these **Type** menus will not contain a Digital option. Multiple gating is only performed on overall (static), process, speed or digital measurements and it cannot affect gating of dynamic measurements.

Condition is the gating parameter range with minimum and maximum values.

Max allowed delta is maximum accepted change of the gating parameter during the measurement. Use this setting to force the system to take data when the operating mode of the machine is stable which may be the only way to capture the accurate and trustworthy data.

This is an important setting when performing a process measurement point on variable speed machines. This is not important for a speed measurement point.

It depends on the application. For example, for measuring bearing temperature, this function can be deactivated by setting it to 0.

Average is a type of averaging which the system should perform on the data before it is stored to the database.

For example, for FFT selecting frequency for the average and 4 for the number, the MasCon/WindCon device will take 4 FFT's, average them and store the averaged FFT in the database. If average is selected as time synchronous, the device will filter out vibrations that are not synchronous to the speed of the shaft where vibration data is taken. Note that the trigger speed measurement indication, **Trigg.** must be set in the [Associated Measurements](#) of the **Acquisition** tab settings.

Number is the number of averages that should be taken for the specified average type selected from the above.

Interval is the desired interval for data capturing. It depends on the application.

Interval alarm is the desired interval for data capturing when the level is in warning or alarm condition.

System log is a configuration log of all the changes made to the measurement point.

Shaft Properties Tab

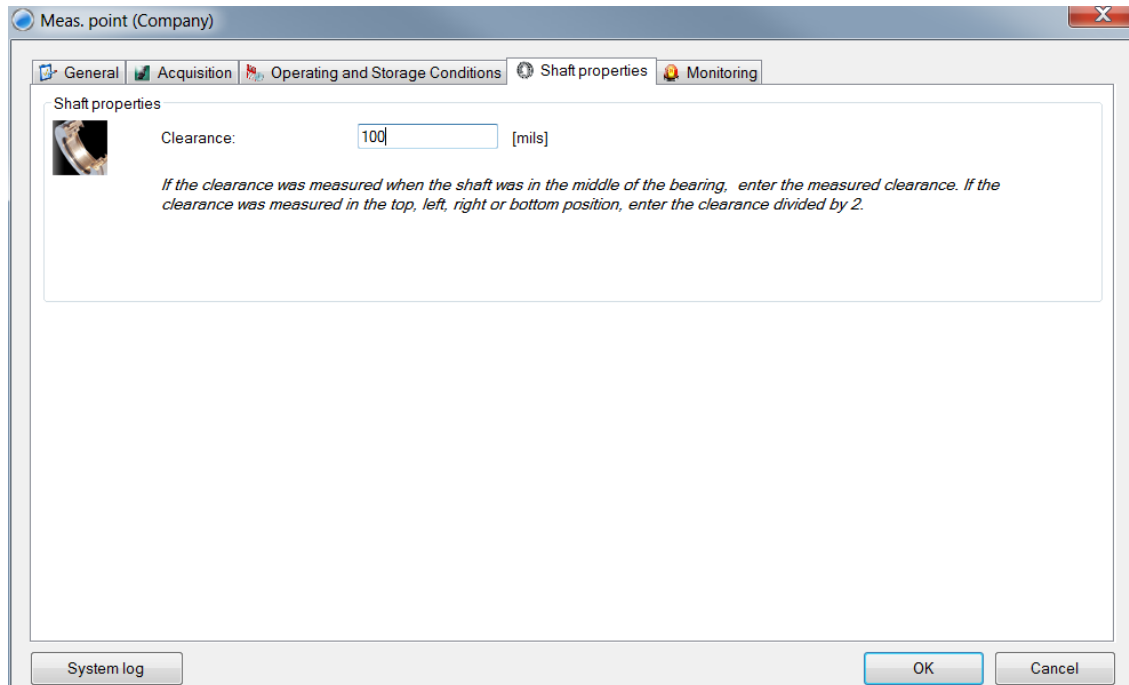

Figure 4 - 45.
Example of Shaft Centerline Measurement Point Shaft Properties Settings.

Shaft properties area

Clearance is the total bearing clearance divided by 2. If the clearance was measured when the shaft was in the middle of the bearing, the measured clearance should be entered. If the clearance was measured when the shaft was in the top, left, right or bottom position, the measured clearance divided by 2 should be entered.

System log is a configuration log of all the changes made to the measurement point.

Monitoring Tab

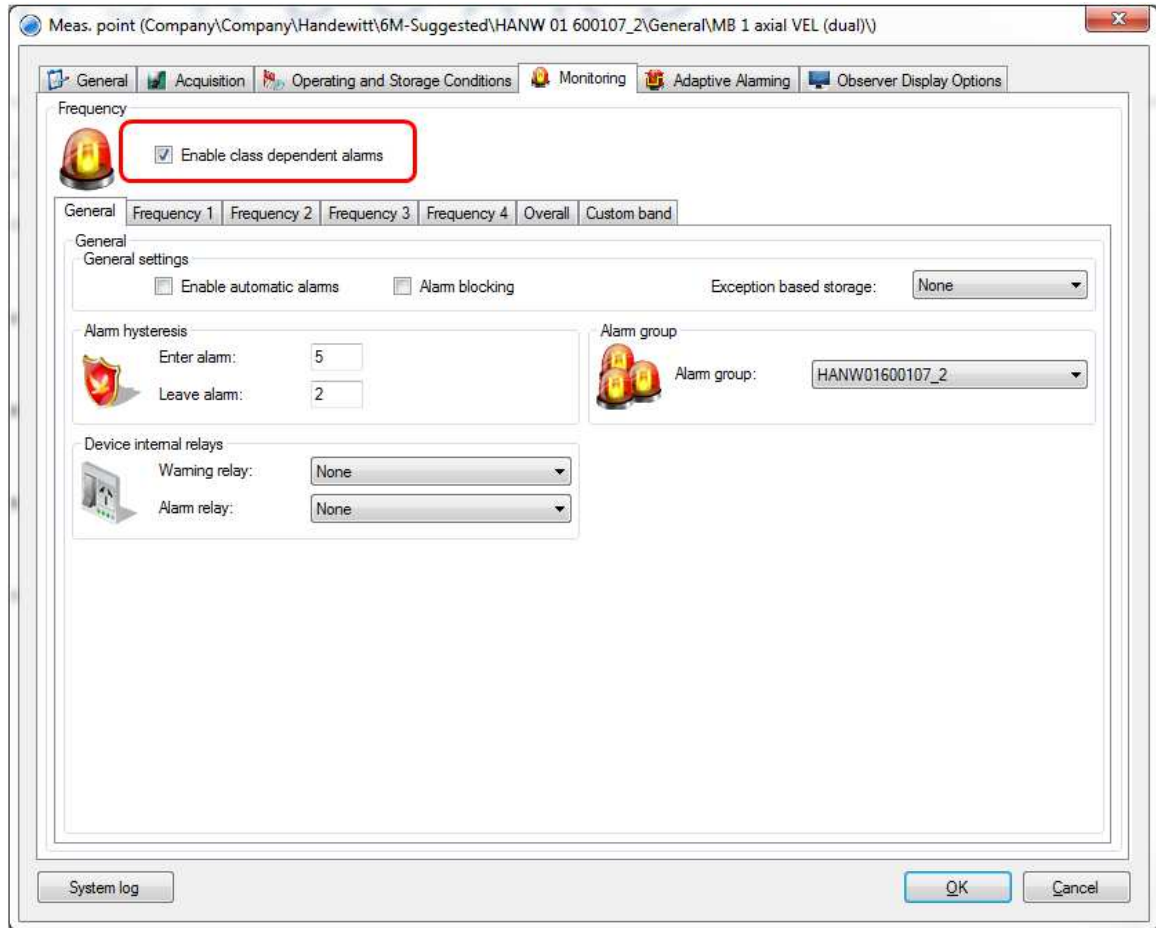

Figure 4 - 46.
Example of Dynamic Measurement Point Monitoring Settings.

Frequency area

Enable class dependent alarms box (for Dynamic and Dynamic Envelope points only), when selected (checked), enables extra alarms dependent on the two Multiple Gating Point operating classes and disables other alarms. If disabled, alarms and diagnoses are calculated for all classes.

When a Multiple Gating Point has been selected as the digital gating Condition on the Operating and Storage Conditions tab, this box become enabled but remains deselected (unchecked) by default.

When this checkbox is selected (checked), the system performs the following actions:

- Disables the Adaptive Alarming area on the **Adaptive Alarming** tab.
- Displays two alarm levels on each of the **Monitoring** tab's **Frequency #** sub-tabs and **Overall** sub-tab corresponding to the two Multiple Gating Point operating classes.
- Disables the **Level ctrl** checkbox on each of the **Monitoring** tab's **Frequency #** sub-tabs and **Overall** sub-tab.

- Hides the **Store delta** text box on each of the **Monitoring** tab's **Frequency #** sub-tabs and **Overall** sub-tab.
- Disables the **Monitoring** tab's **Custom Bands** sub-tab.

General sub-tab, **General settings** area

Enable automatic alarms checkbox enables the automatic alarm functionality when checked.

Automatic alarm enables the measurement point to use automatic levels for the selected active trend alarms. The system will automatically calculate the alarm and warning level after a minimum specific number of historical values have been stored in the database.

For Microlog Analyzer measurement points, the minimum number of trend values to calculate the automatic alarm levels is five and it will be based on a maximum of 40 measurements. For IMx/MasCon measurement points, the minimum number of trend values to calculate the automatic alarm levels is 20 and it will be based on a maximum of 100 measurements.

The calculation algorithm uses a specific number of standard deviations from the average level to determine the warning level. The number of standard deviations is determined by **Auto alarm** setting on the **Thresholds** tab for [Options](#) under Database in Menu Items. To determine the alarm level the system uses twice as many standard deviations as for the calculation for the warning level.

When a new trend value is stored in the database, the system always checks if new automatic alarm levels should be set for the measurement point. Once they are set, they will not be recalculated again unless the user specifically resets the automatic alarm levels by editing the measurement point properties or by right-clicking in the hierarchy and selecting **Reset the automatic alarm levels**.

When the system has calculated the warning and alarm levels for the active alarms on a measurement point, the measurement point properties will be updated with the new levels and the system log for the measurement point will be updated as well.

When a new measurement point is created by copying an existing measurement point with the automatic alarm enabled, the alarm level of the new measurement point will be set to 0. The automatic alarm for the new measurement point will be calculated when enough data has been stored for the new measurement point.

Automatic alarm cannot be combined with adaptive alarm.

Alarm blocking is a setting that makes it possible to temporarily disable the alarm check.

Exception based storage is a setting of what to store if the trended value changes.

General sub-tab, Alarm area

This section is to set up the alarm levels for the measurement. Individual alarms can be disabled as applicable.

High alarm is the status of high alarm which can be enabled or disabled.

High warning is the status of high warning which can be enabled or disabled.

Low warning is the status of low warning which can be enabled or disabled.

Low alarm is the status of low alarm which can be enabled or disabled

Condition triggers the alarm to be raised. The options are none, opened and closed.

General sub-tab, Alarm hysteresis area

This section controls how many times a value can be over and under the alarm limits before @ptitude Observer goes into or releases the alarm state.

Enter alarm is the number of consecutive measurements that must be over the alarm level before an alarm is reported. Default is set to 2.

Leave alarm is the number of times that a value must be under the alarm level before @ptitude Observer releases the alarm state. Default is set to 5.

General sub-tab, Alarm group area

It is a setting that makes the system store data for all the members in the group if one of the members triggers an alarm.

General sub-tab, Device internal relays area

Warning relay on the WindCon/IMx/MasCon device is used when a warning level is reached. It can be used to trip the machine upon warning.

Alarm relay on the WindCon/IMx/MasCon device is used when an alarm level is reached. It can be used to trip the machine upon alarm.

General sub-tab, Vector alarming area

Type is a selection of alarm type in the complex plane. This setting can be either Circular or Sector.

Frequency # sub-tab

Type is the type of frequency band or time waveform component to monitor.

For frequency:

Fixed frequency: monitors a specific frequency with a search area around in order to trend.

Speed following: monitors specific frequencies related to the speed of the machine when machine speed varies. It is possible to set up to monitor a specific gear on the selected machine part by choosing a machine part from the drop-down list.

x N sub-tab

Level ctrl. triggers the alarm levels to be automatically adjusted according to the settings and curve information provided in [Adaptive Alarming Tab](#) in Setting up Measurement Points and Alarms.

Channel X Enabled enables the Channel X.

Channel X Warning level / Alarm level sets up normal level alarm warning and alarm for trends 1 x N, 2 x N, 3 x N and 4 x N.

Overall sub-tab

This section is used for an overall measurement by setting up the system to display/calculate the value.

Type specifies the method to use to calculate the overall.

Frequency band means that the overall will be calculated from a defined band in the frequency domain.

TruePtP means that the overall will be calculated from the time waveform (true peak-peak) and then scaled to RMS, peak or peak-peak (=no scaling) according to the Trend Configuration settings in the Acquisition tab.

None means the overall is not calculated.

Name is the name of the alarm for the measurement point.

Start is the start frequency of the frequency band to monitor.

Stop is the end frequency of the frequency band to monitor.

Level ctrl. triggers the alarm levels to be automatically adjusted according to the settings and curve information provided in [Adaptive Alarming Tab](#) under Setting up Measurement Points and Alarms in System Configuration.

Relation indicates a percentage, which means that the system will trigger an alarm if the ratio exceeds the number set in this field. The ratio is calculated by $(\text{Total} - 1 \times N - 2 \times N - 3 \times N - 4 \times N) / \text{Total}$. Relation alarm monitors the frequencies in between the frequencies: 1 ' N, 2 ' N, 3 ' N and 4 ' N, for example, sub harmonics.

Alarm - Warning level/Alarm level is the warning level/alarm level of the Channel X alarm.

Custom band sub-tab

Band is the band number.

Name is the name of the band.

Type is the type of frequency or time waveform component to monitor:

Fixed frequency monitors a specific frequency with a search area around in order to trend.

Frequency band means that the overall will be calculated from a defined band in the frequency domain.

Speed following monitors specific frequencies related to the speed of the machine when machine speed varies. The system can be set to monitor a specific gear on the selected machine part by choosing a machine part from the drop-down list.

From time waveform means that the overall will be calculated from the time waveform (true peak-peak) and then scaled to RMS, peak or peak-peak (no scaling) according to the Trend Configuration settings in the Acquisition tab.

None means custom band is not being used.

Source is the selection of sensor multi-channel points.

HW is the high warning level.

HA is the high alarm level.

Additional configuration levels are available on selecting a custom band on this list and clicking **Edit**.

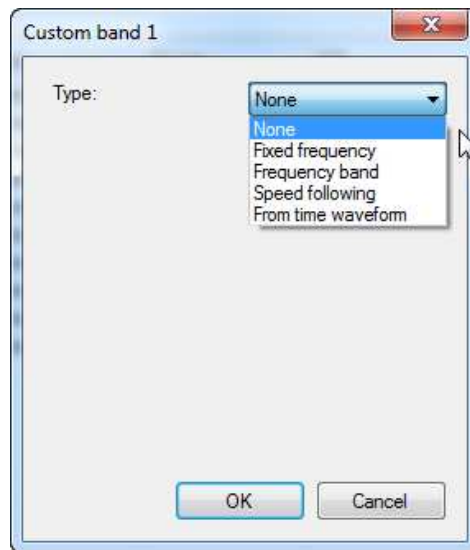

Figure 4 - 47.
Example of Edit Custom Band Dialog, Type.

In the **Custom band x** dialog, the **Type** options match those just described above. On selecting the **Type**, additional fields display. The examples below show the available options for Fixed Frequency and for Speed Following.

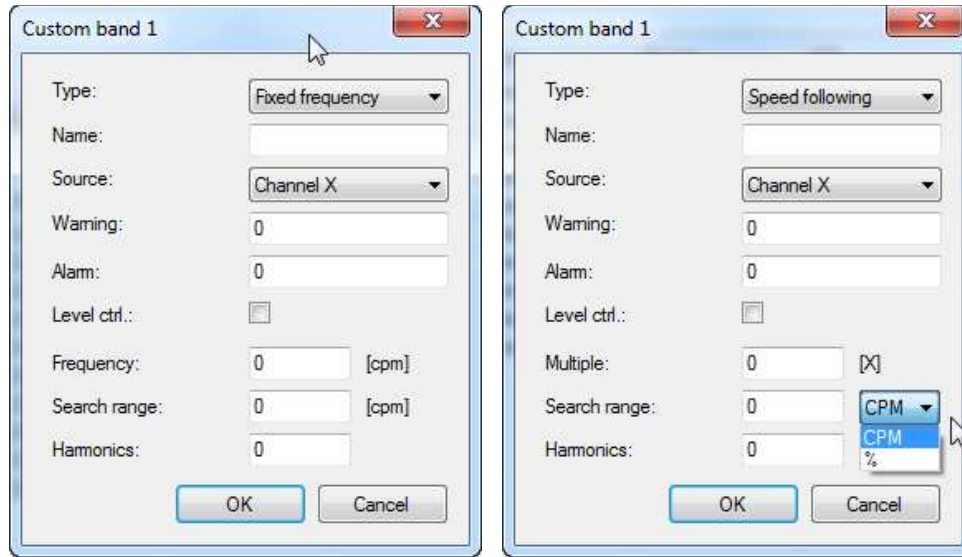

Figure 4 - 48.
Examples of Edit Custom Band Dialog with Different Types.

Source is the selection of sensor multi-channel points.

Alarm - Warning level/Alarm level is the warning level/alarm level of the Channel X alarm.

Level ctrl. triggers the alarm levels to be automatically adjusted according to the settings and curve information provided in [Adaptive Alarming Tab](#) in Setting up Measurement Points and Alarms.

Search range performs a search for maximum amplitudes within this range.

Harmonics specifies the number of harmonics that should be included in the calculation.

Adaptive Alarming Tab

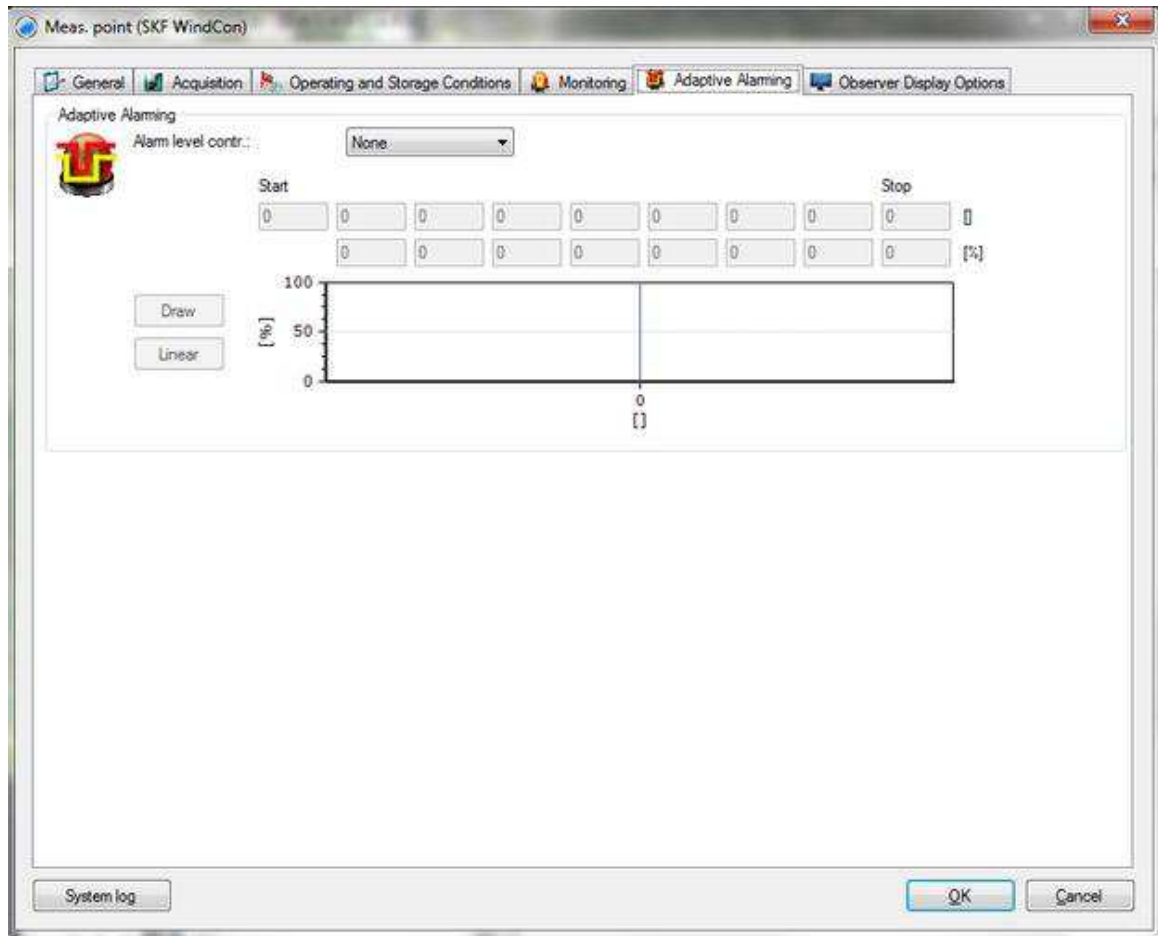

Figure 4 - 49.
Example of Dynamic Measurement Point Adaptive Alarming Settings.

Adaptive Alarming area

- If the **Enable class dependent alarms** box (for Dynamic and Dynamic Envelope points only), on the **Monitoring** tab is selected (checked), then all controls on this tab are disabled.

Note that to activate advanced settings for each trend, Level ctrl in [Monitoring Tab](#) under Setting up Measurement Points and Alarms in System Configuration, must be set.

Alarm level contr. controls the alarm levels; for example, for rotational speed or a process value such as motor load. Use the graph and its settings to construct the curve to be used for altering the alarm levels during measurement.

Start / Stop defines the range in which the control is to take place. The boxes above the graph are used to specify the alarm values as percentages of the alarm levels set in the [Monitoring Tab](#).

System log is a configuration log of all the changes made to the measurement point.

Transient Tab

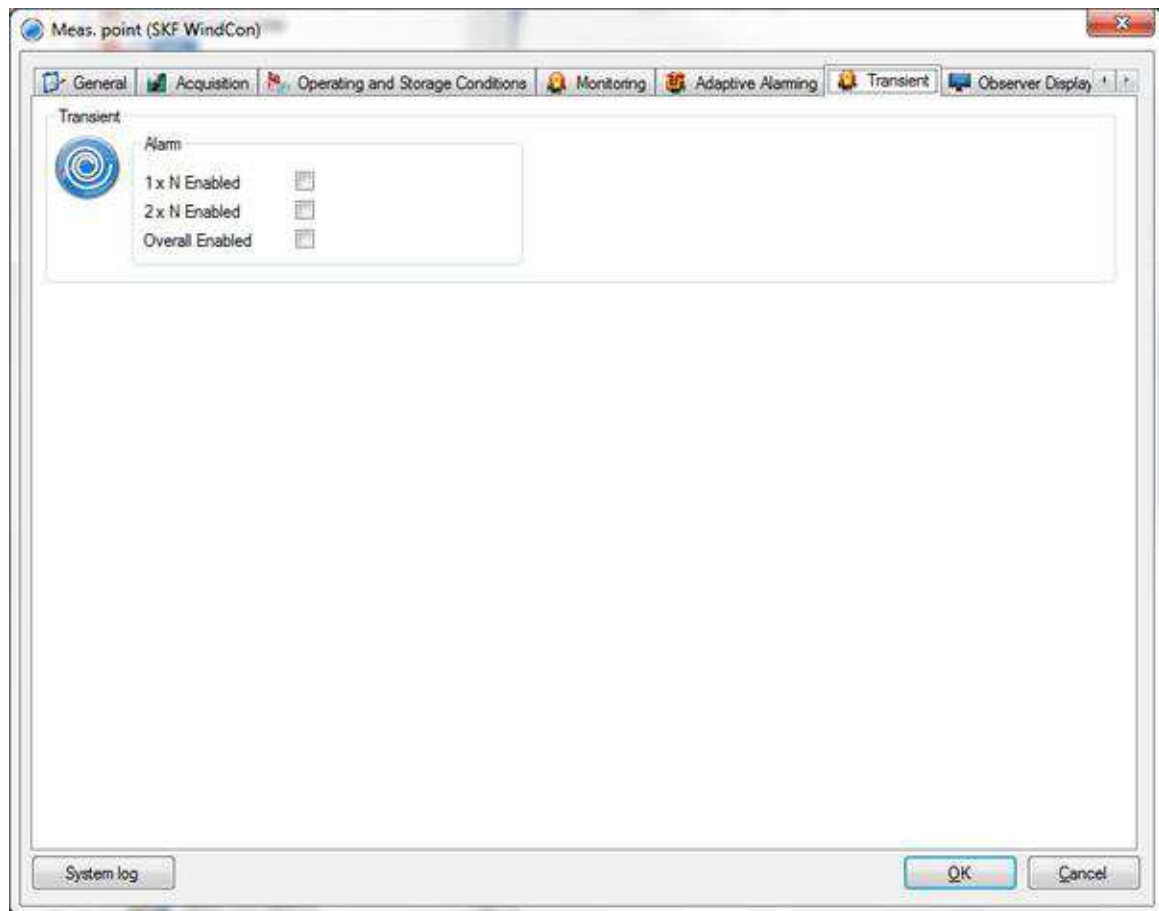

Figure 4 - 50.
Example of Harmonic Measurement Point Transient Settings.

Transient area

Alarm indicates whether to enable or disable alarms in transient ranges such as 1 x N, 2 x N and Overall in the measurement group.

System log is a configuration log of all the changes made to the measurement point.

Observer Display Options Tab

This setting contains information related to the display of information to the user but which has nothing to do with the measurement itself.

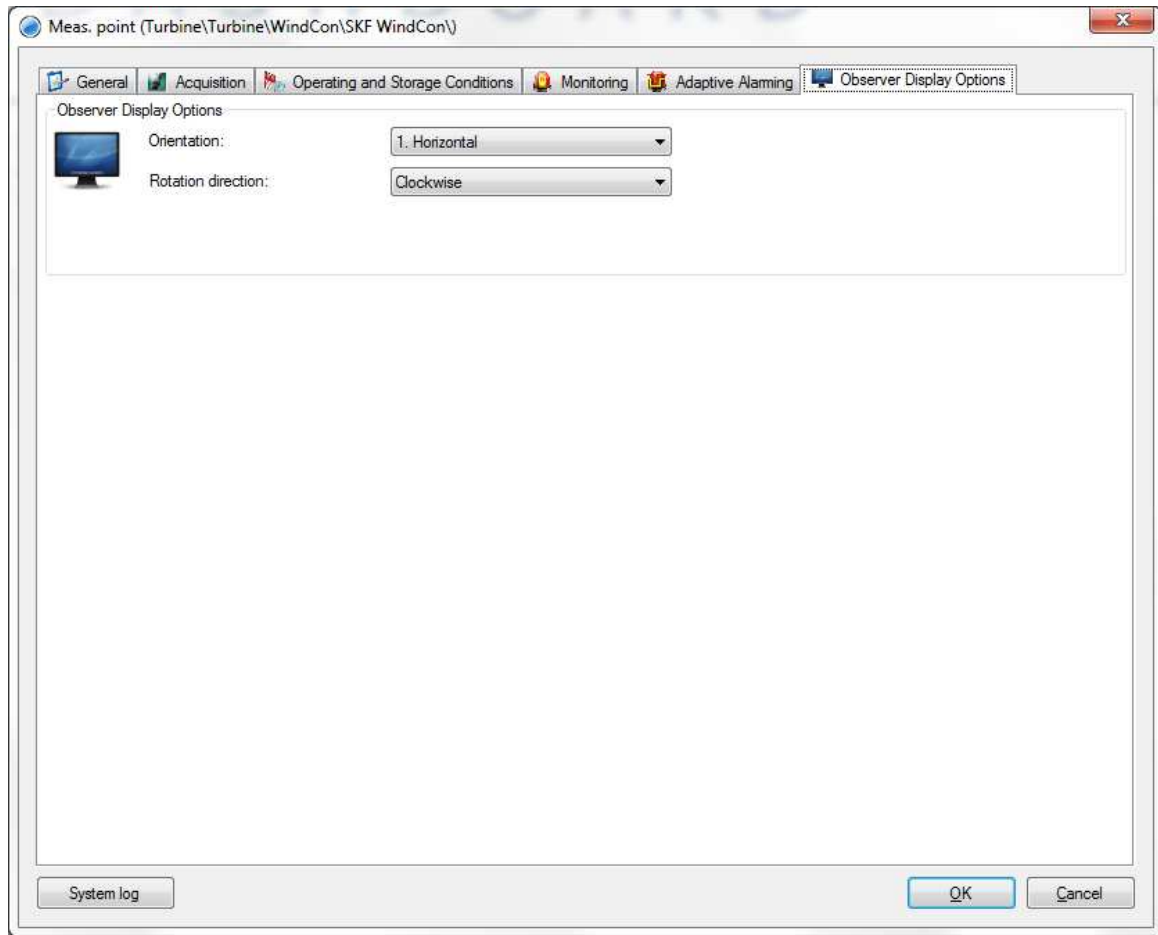

Figure 4 - 51.
Example of Dynamic Measurement Point Observer Display Options Settings.

Observer Display Options area

Orientation is a suitable sensor orientation which can be 1. Horizontal, 2. Axial, 3. Vertical, 4. Tangential, 5. Radial or 6. Axial/Vertical.

Rotation direction indicates the rotational direction which can be Clockwise or Counter-clockwise.

Order analysis shaft is the shaft on the machine that should be used for order analysis in the spectrum, history and 3D plot.

System log is a configuration log of all the changes made to the measurement point.

About Multiple Gating Points

A Multiple Gating Point (MGP) is a point type that references values from up to five other points and then performs a logical evaluation on the current measurements to determine if the IMx should take measurements. Each reference point has two distinct gating conditions, Operating Class 1 or Operating Class 2, with the point output determined by which set of the two gating conditions is set to TRUE. These reference measurements can include process, speed and digital measurements.

The display name of the operating classes can be edited on **Database > Options, Data** tab.

To create an MGP:

- Within the Hierarchy view, right-click on the machine or sub machine that the MGP is being added to and select **Add > Meas. point** from the resulting context menu. The **New meas. point** screen appears.
- Click on the **IMx** device option on the left side of the screen.
 - The measurement point type options available vary depending on the device selected.
- Click on the **Multiple Gating, Process** measurement point option and click **OK** (or double-click on the **Multiple Gating, Process** option). A new **Meas. point** screen appears with the **General** tab displayed.

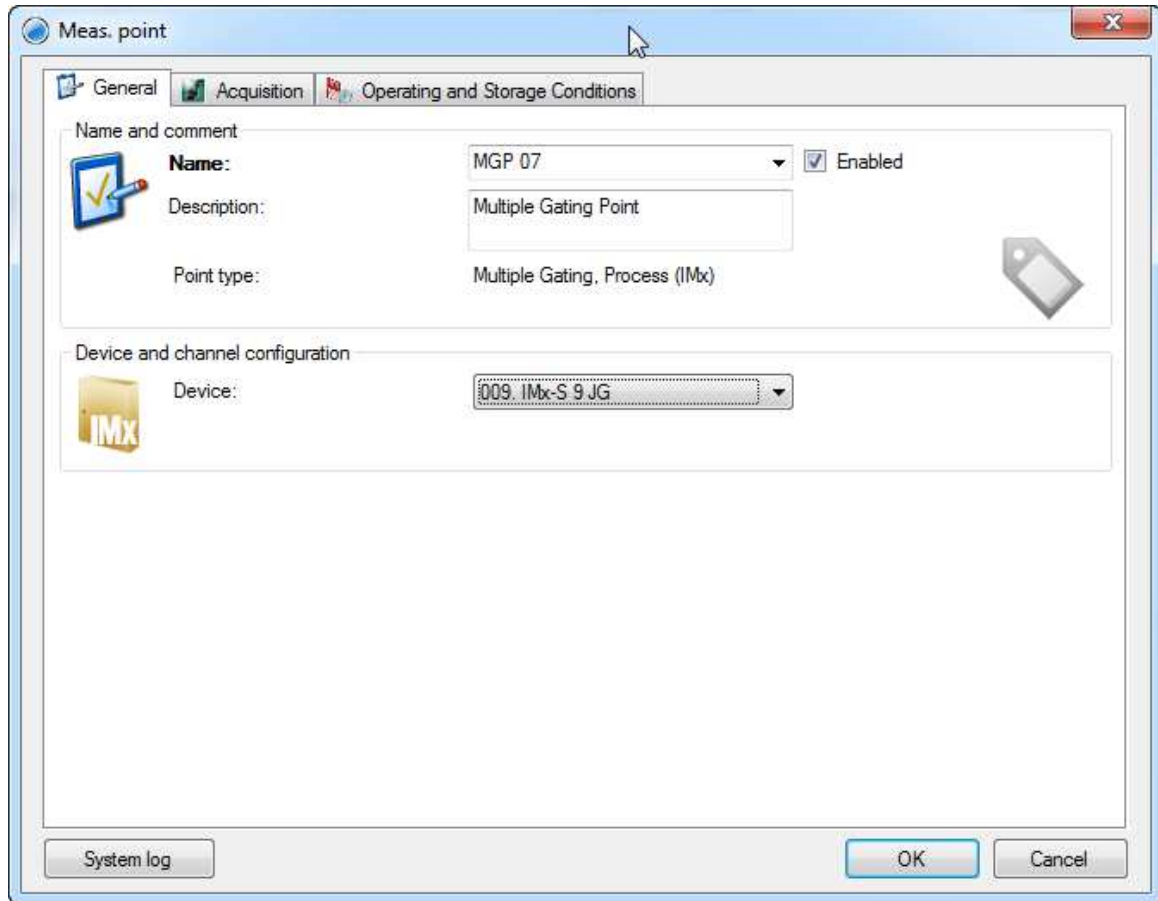

Figure 4 - 52.
Meas. Point Screen's General Tab for New MGP.

- Enter a **Name** and **Description** for the new MGP.
- Select the IMx that is collecting the measurement data from the **Device** drop-down list button.
- Click on the **Acquisition** tab.

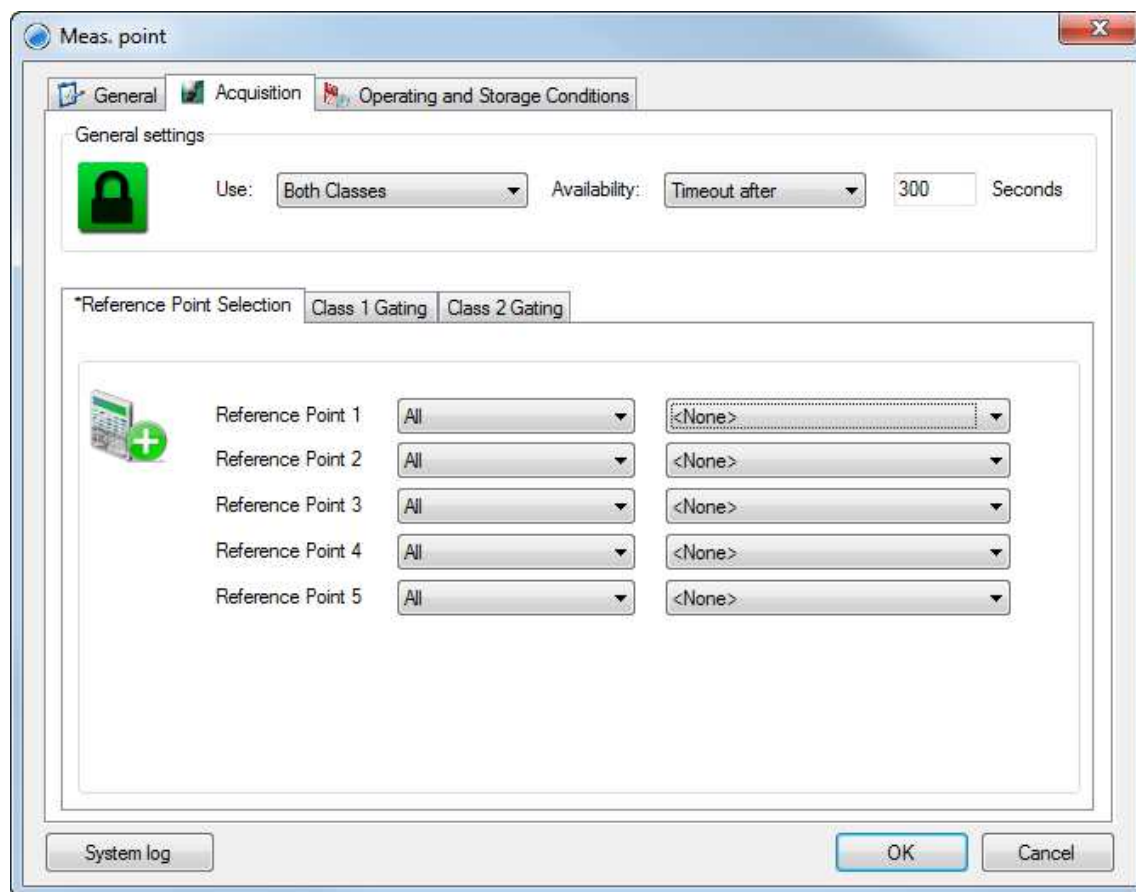

Figure 4 - 53.
 Meas. Point Screen's Acquisition Tab (Reference Point Selection Sub-Tab) for New MGP.

- From the **Use** drop-down list button, select whether the MGP will base its evaluation on a Single Class or Both Classes. When Single Class is selected, a single gate range can be set for each of the five reference points (on the **Class 1 gating** sub-tab). When Both Classes is selected, two different gate ranges can be set for each of the five reference points (on the **Class 1 gating** and **Class 2 gating** sub-tabs).
- From the **Availability** drop-down list button, select if and how gating should be suspended if one of the required reference points becomes unavailable:
 - Timeout after: Select to have the system suspend gating until a specified period of time has elapsed. Enter that period (in seconds). The default is 300 seconds.
 - Timeout disabled: Select to have the system continue gating.
 - On next evaluation: Select to have the system suspend gating until the next measurement.
- On the **Reference Point Selection** sub-tab, select up to five points from the selected IMx unit for the Multiple Gating Point to reference. From each left drop-down list button, select a point type to reference from the IMx: All, Process, Digital or Speed. From the right drop-down list button in the same row, select a

measurement point to reference from the IMx. Options in this drop-down are filtered based on the target point type selected.

- If All was selected from the left drop-down list button, that point type will update according to the measurement point selected from the right drop-down list button.
 - A measurement point reference list can be reset at any time by selecting All from the point type list.
- Click on the **Class 1 Gating** sub-tab.

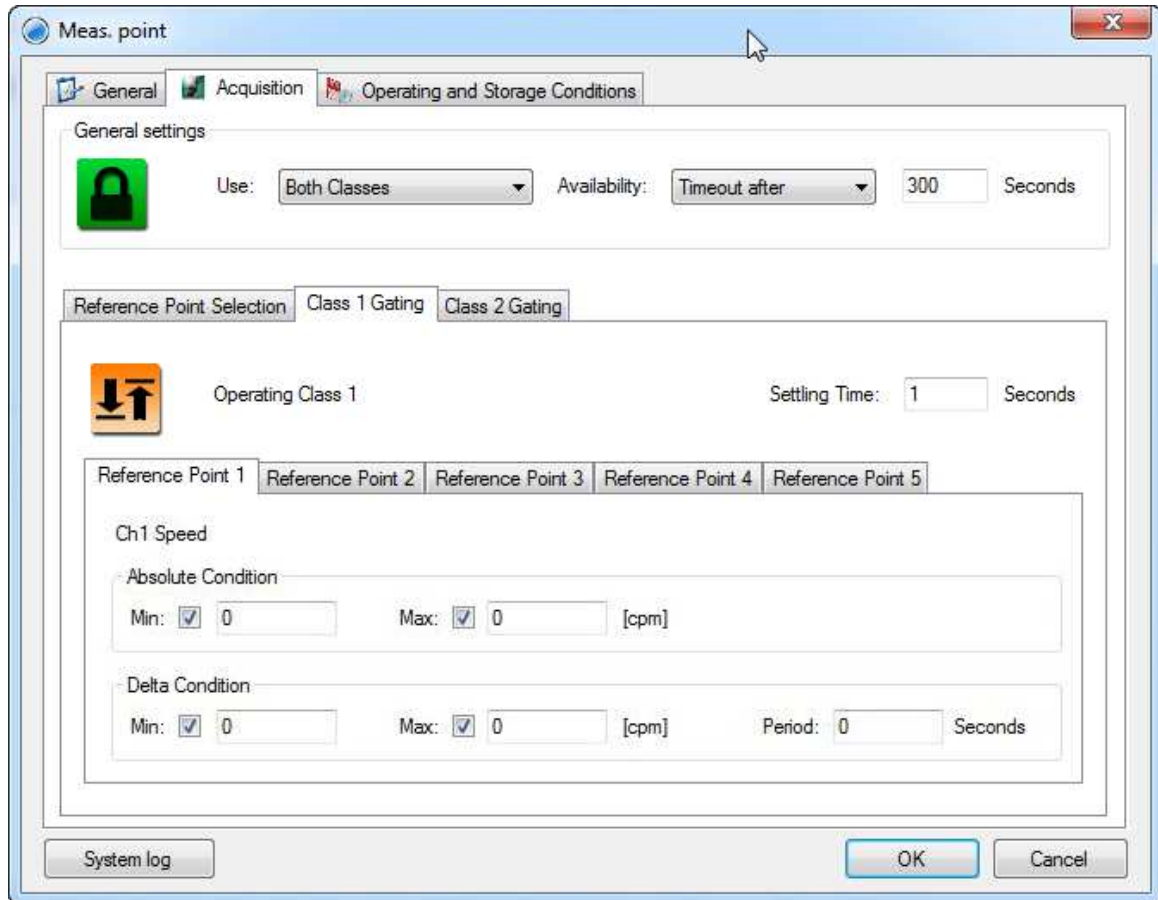

Figure 4 - 54.
Meas. Point Screen's Acquisition Tab (Class 1 Gating Sub-Tab) for New MGP.

- The class name that appears at the top of this sub-tab is a global property set from the **Database > Options** screen's **Data** tab.
- In the **Settling Time** text box, enter the number of seconds, upon entering a cable fault alarm status, for which Observer will remain in this status once sensor power is restored, given the applicable operating class. The default is 1 second.

- On the **Reference Point 1** sub-tab, select the gating conditions for that reference point:
 - Select (check) the **Min** and/or **Max** checkbox(es) and then enter a value or values to set an **Absolute condition** gating parameter range.
 - If either value must be a negative number, include a minus sign (-) before the number.
 - If both **Min** and **Max** are selected, the gating parameter range falls between the two. If either is not selected, the range extends infinitely in that direction.
 - Select (check) the **Min** and/or **Max** checkbox(es) and then enter a value or values to set a **Delta condition** permitted parameter change range.
 - If either value must be a negative number, include a minus sign (-) before the number.
 - If both **Min** and **Max** are selected, the accepted gating parameter change range falls between the two. If either is not selected, the range extends infinitely in that direction. If neither is selected, there is no accepted gating parameter change range.
 - Enter the **Period**, in seconds (up to 60), for which the system must check the **Delta Condition** thresholds.
 - **Delta Condition Period** is disabled if both the **Min** and **Max** checkboxes are deselected (unchecked).
- Continue selecting gating conditions for the other reference points on their respective tabs, as appropriate.
 - These sub-tabs are enabled for assigned reference points only.
- If appropriate, click on the **Class 2 Gating** tab to assign a **Settling Time** and select gating conditions for the reference points, for that class.

Important - One or more of the reference point gating ranges (conditions) must be different between two classes.

Digital point example, Acquisition tab

To have digital point gating in one class but not in the other, a **Condition** checkbox is provided for each **Reference Point** sub-tab on the **Class 1 Gating** and **Class 2 Gating** tabs.

When the **Condition** checkbox is not selected, the condition is excluded from the MGP evaluation without de-referencing the digital point in the Reference Point Selection tab.

When the **Condition** checkbox is selected, a drop-down combo box displays to its right, with the options Open or Closed for the digital parameter.

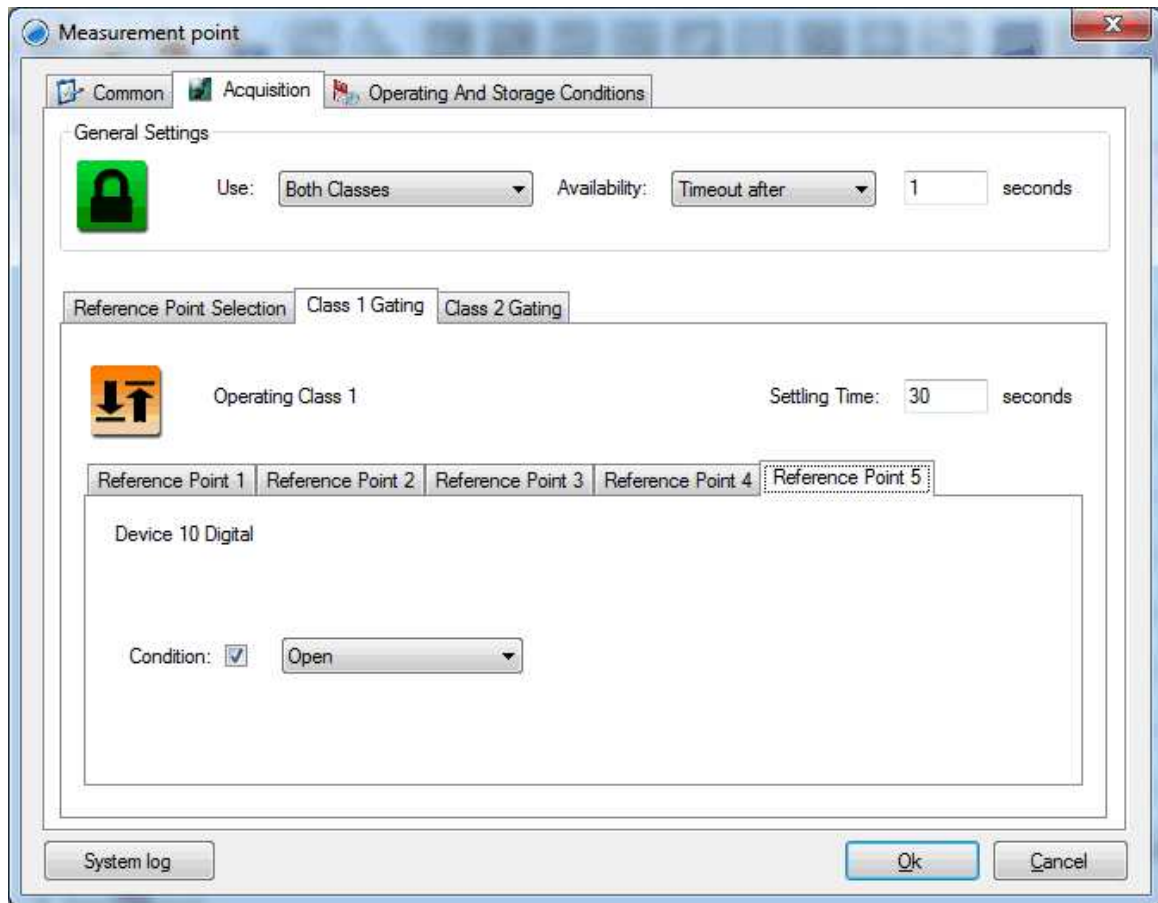

Figure 4 - 55.
Meas. Point Screen's Acquisition Tab, Reference Sub-Tab for a Digital Point.

- Click on the **Operating and Storage Conditions** tab.

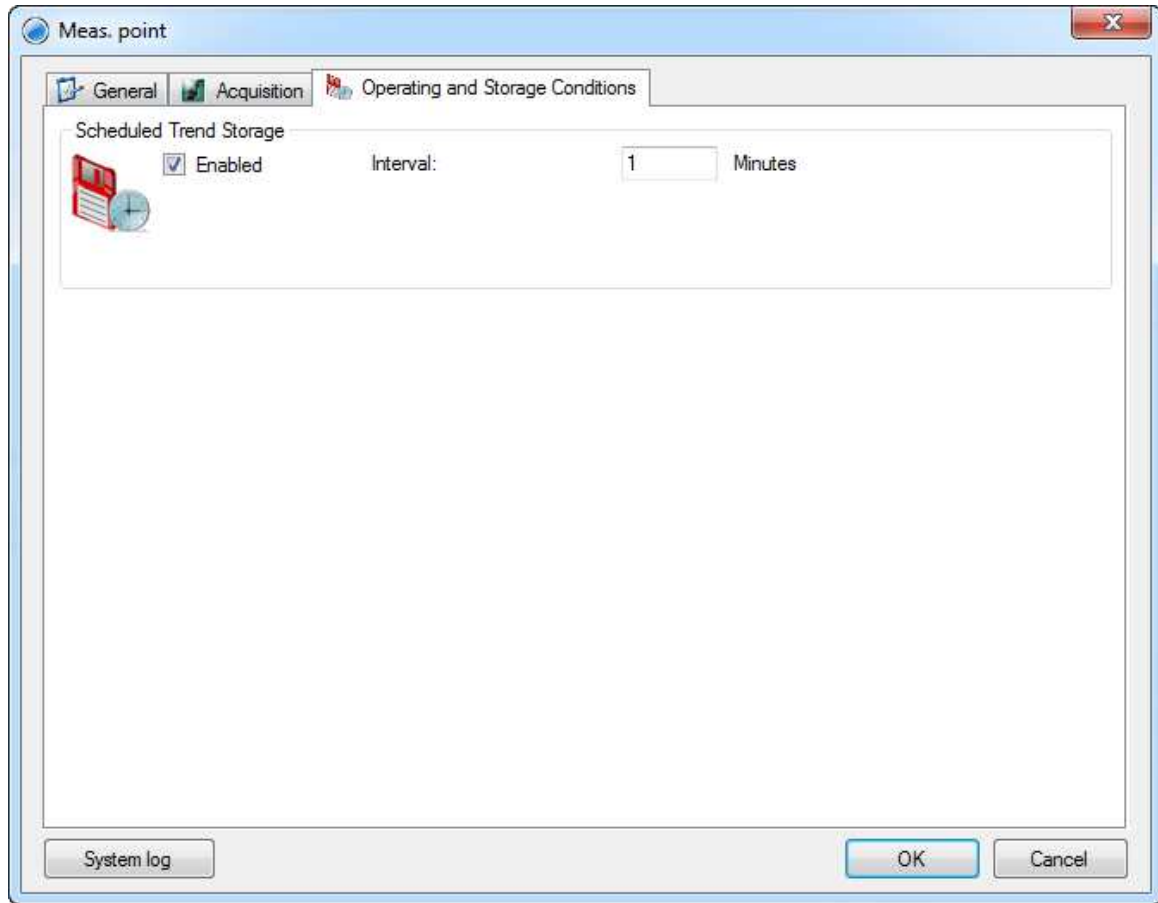

Figure 4 - 56.
Meas. Point Screen's Operating and Storage Conditions Tab for New MGP.

- Keep the **Enabled** box selected (checked) to have the **Scheduled Trend Storage** function enabled.
- Enter the desired **Interval** for data capturing.
- Keep the **Exception based storage** box selected (checked) to only store trend values for those measurements that reflect trend value changes.
- Click **OK** to finish creating and save the new MGP.

To set an existing (or newly-created) Dynamic or Dynamic Envelope point to be referenced by the Multiple Gating Point:

- Create a new Dynamic or Dynamic Envelope type IMx measurement point. The new measurement point screen opens with the **General** tab displayed.

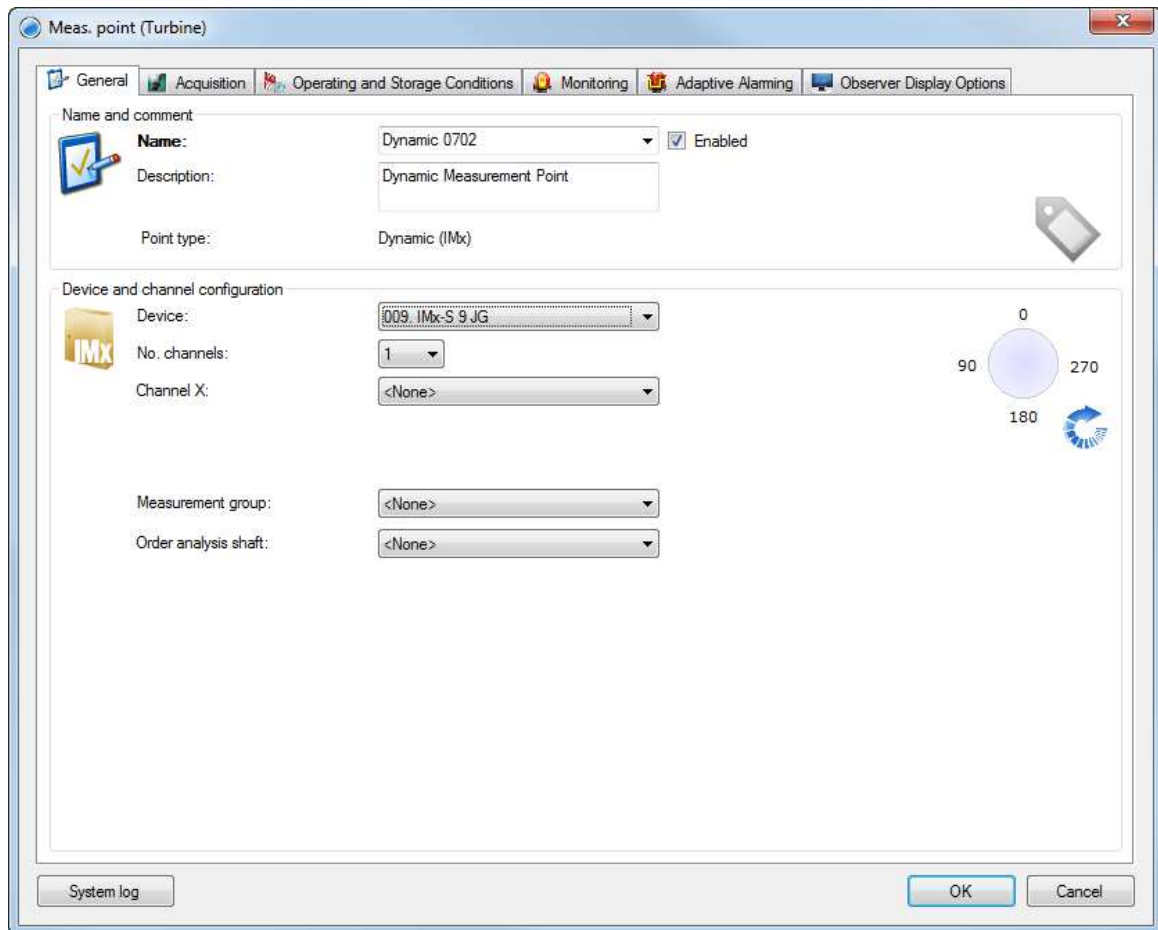

Figure 4 - 57.
Associating a Dynamic Measurement Point with a Multiple Gating Point – General Tab.

- Enter a **Name** and **Description** for the point.
- Select the desired IMx.
- Select 1 from the **No. channels** drop-down list. Multiple Gating Points can reference only single channel points.
- Complete other **Device and channel configuration** information as appropriate.
- Click on the **Acquisition** tab.

System Configuration

Setting up Measurement Points and Alarms

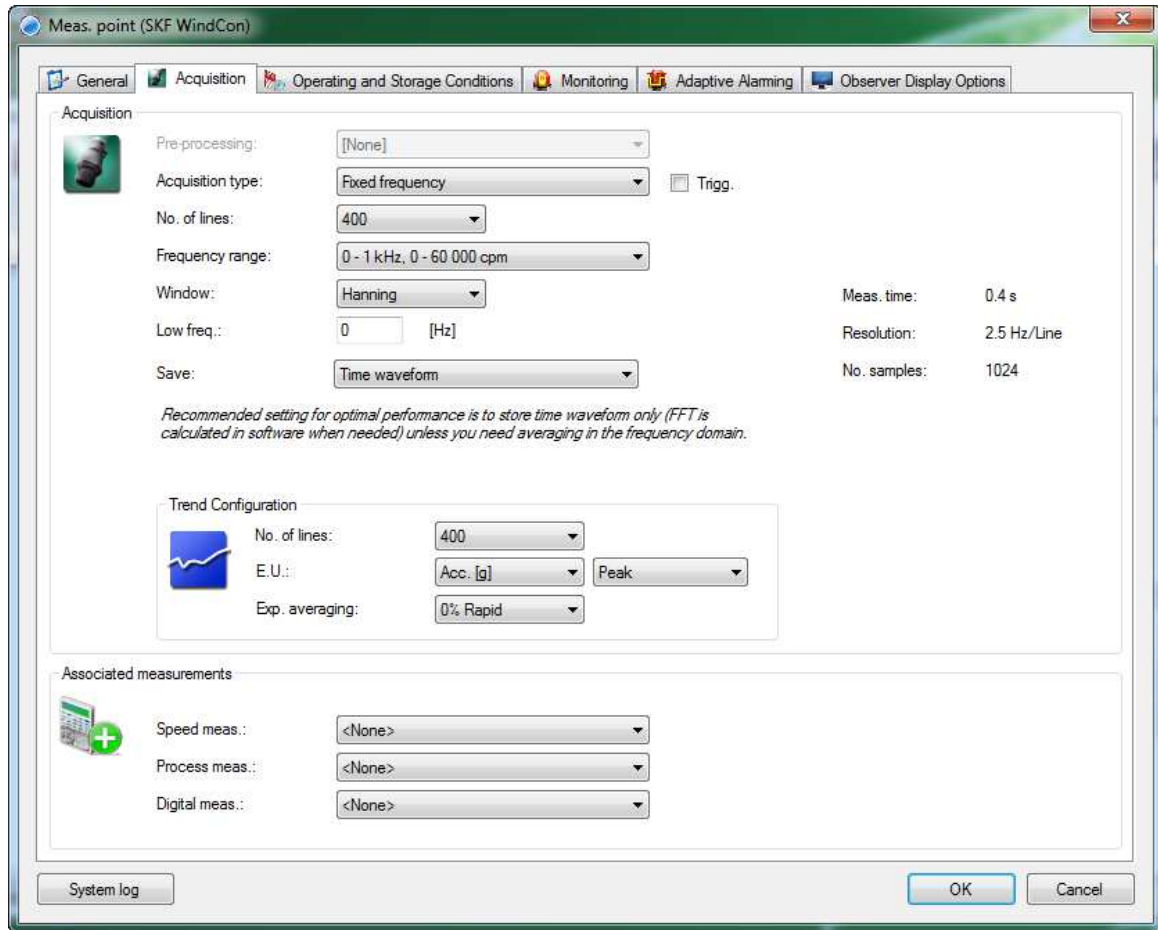

Figure 4 – 58.
Associating a Dynamic Measurement Point with a Multiple Gating Point – Acquisition Tab.

- Complete **Acquisition** information as appropriate.
- Select the desired Multiple Gating Point from the **Associated measurements** area's **Digital meas.** drop-down list box.
- Click on the **Operating and Storage Conditions** tab.

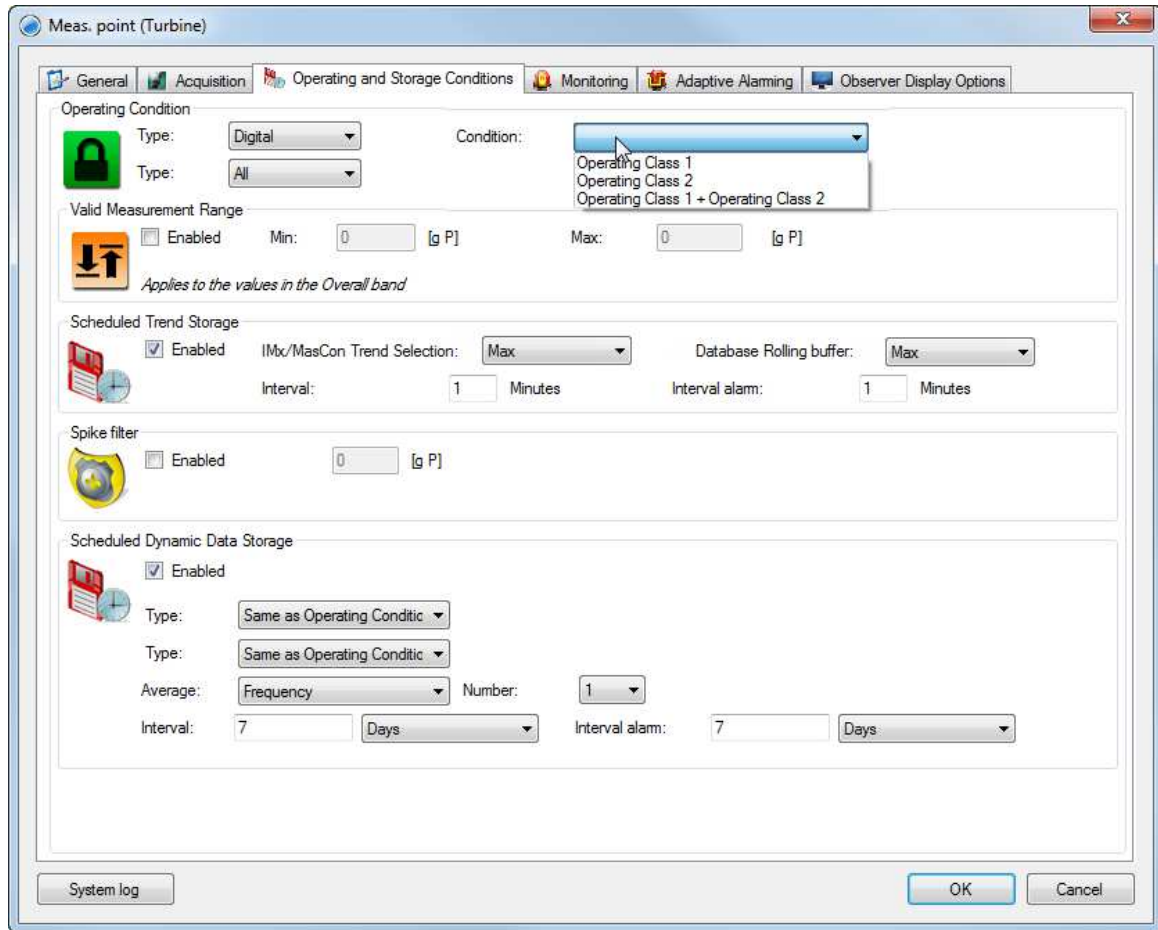

Figure 4 - 59.

Associating a Dynamic Measurement Point with a Multiple Gating Point – Operating and Storage Conditions Tab.

- Select Digital from either of the **Operating conditions** area's **Type** drop-down list boxes. The **Condition** drop-down list box appears.
- Select one or both Multiple Gating Point operating classes from the **Condition** drop-down list box.
- Click on the **Monitoring** tab.

System Configuration Setting up Measurement Points and Alarms

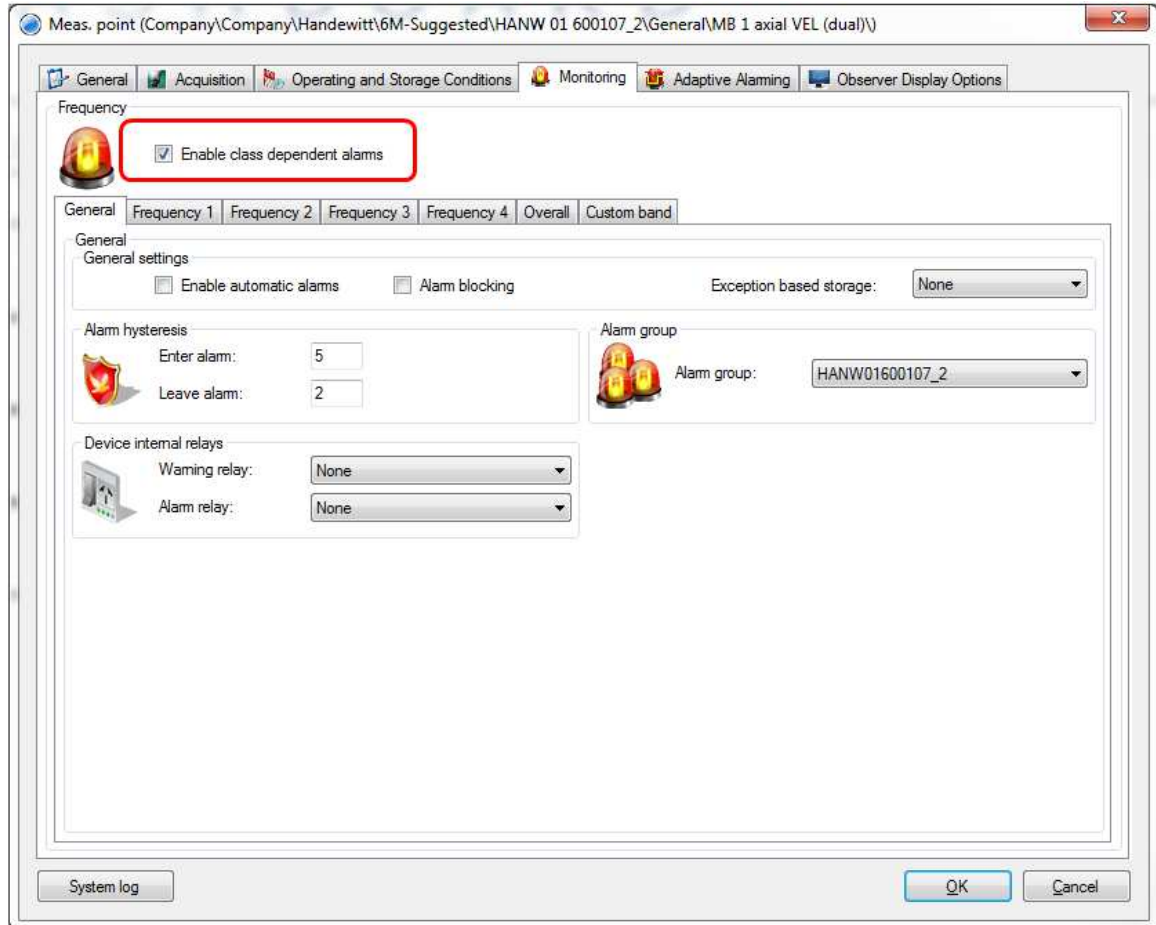

Figure 4 - 60.
Associating a Dynamic Measurement Point with a Multiple Gating Point – Monitoring Tab.

- If desired, select (check) **Enable class dependent alarms**.

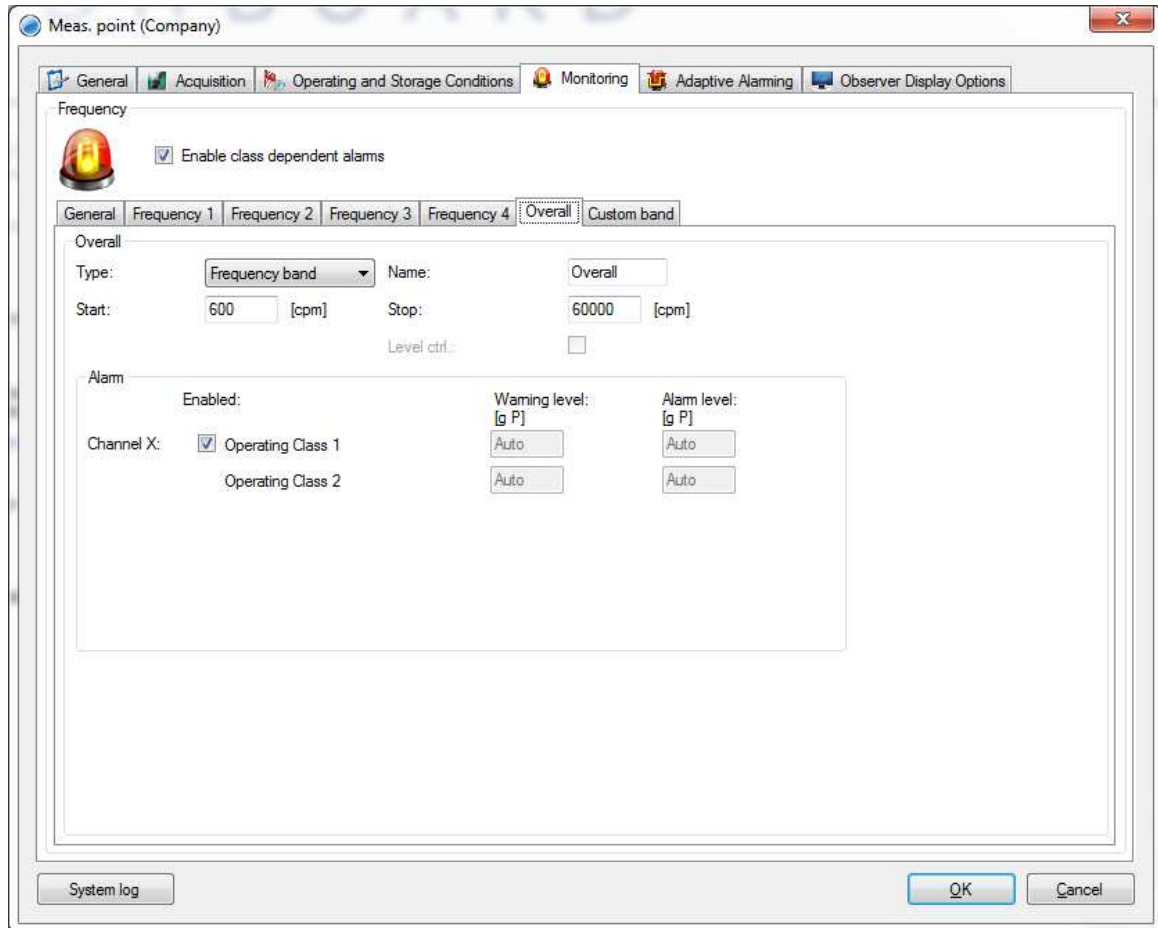

Figure 4 - 61.
Class Dependent Alarms.

When **Enable class dependent alarms** is checked, the following changes occur:

- The Adaptive Alarming area on the **Adaptive Alarming** tab becomes disabled.
- Two alarm levels display on each of the Monitoring tab's Frequency # sub-tabs and Overall sub-tab corresponding to the two Multiple Gating Point operating classes. Separate alarm levels can be set for the two classes.
- The **Level ctrl** checkbox on each of the Monitoring tab's Frequency # sub-tabs and Overall sub-tab becomes disabled.
- The **Store delta** text box on each of the Monitoring tab's Frequency # sub-tabs and Overall sub-tab is hidden.
- The **Monitoring** tab's **Custom Bands** sub-tab becomes disabled.
 - On deselecting (unchecking) **Enable class dependent alarms**, all controls revert to their normal state.

Configuring Runout Compensation

Runout compensation can remove the (pseudo-vibration) signal, that is due to the shaft being out-of-round. Runout Compensation settings can only be applied to harmonic measurement points.

To set the compensation, the shaft is rotated at low speed and sensor values are collected during the slow roll speed range (see transient group configuration).

To start capturing data when in slow roll, right-click on the machine and select "Runout compensation".

Runout compensated data is possible to view in the trend plot and in the polar plot for harmonic measurement points.

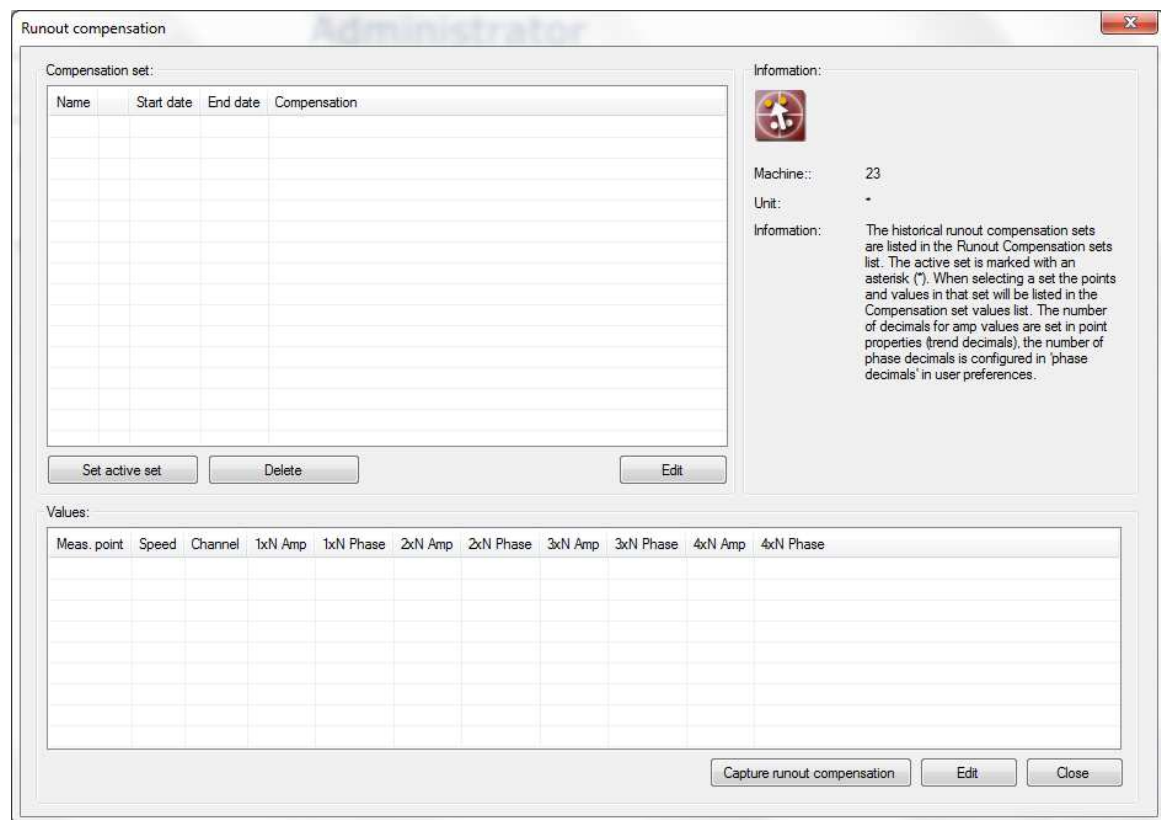

Figure 4 - 62.
Example of Runout Compensation.

Set active set if there are several different sets captured for the machine. The active set that should be used can be set by clicking this button.

Delete deletes the compensation set and its data from the database.

Edit allows the user to edit the properties of captured runout compensation data.

Capture runout compensation opens a new window to capture live data to store in a new runout compensation set.

Edit allows the manual editing of the runout compensation data for a selected measurement point in a set.

Close closes the window.

Editing a runout compensation set

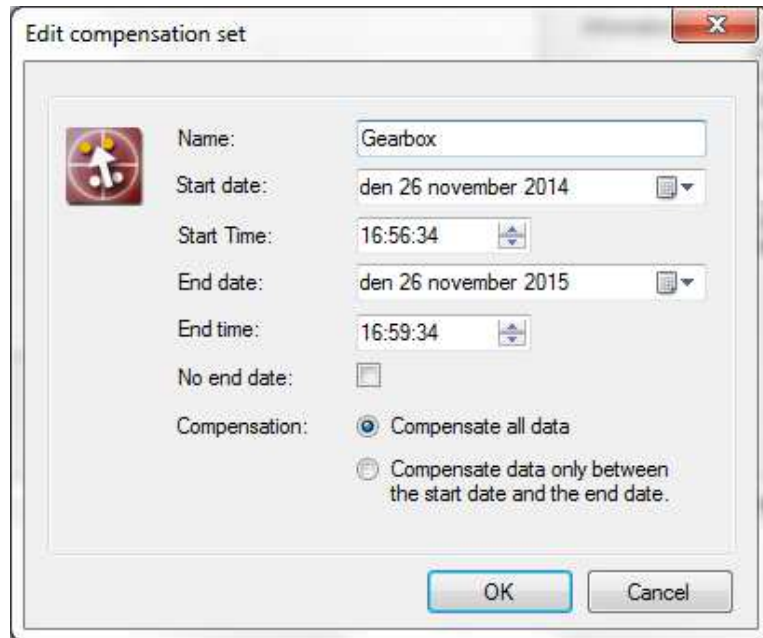

Figure 4 - 63.
Example of Editing Compensation Set.

Name sets a custom name for the set

Start date and Start time sets the start of the set

End date and End time sets the end of the set

No end date box checked indicates that the compensation set will compensate data between the start and the future.

Compensation allows the user to select whether data should be compensated between the start and the end or whether all data should be compensated when using this compensation set in the graphs to display data.

Calibrating Shaft Centerline Graph

To calibrate the shaft centerline graph, right-click in the hierarchy on any of the node types, machine, sub machine or measurement point and select the menu option "calibrate shaft centerline graph".

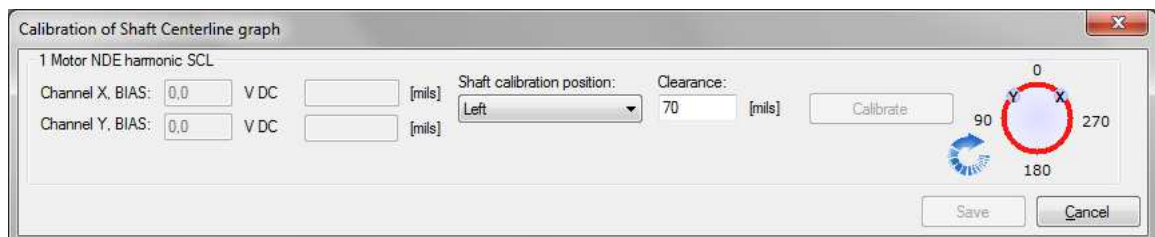

Figure 4 - 64.
Example of Calibration of Shaft Centerline Graph.

Before starting the calibration process make sure that the device is connected and the Monitor service is running. This feature will automatically connect to the

IMx device and retrieve live values for the shaft centerline measurement point and get data of the current location of the shaft.

Shaft calibration position allows the current position of the shaft to be selected and where the shaft should be located after the calibration of the shaft centerline graph has been completed.

Clearance of the bearing should be measured and entered in this dialog box.

Calibrate sets the new calibration parameters for the sensor once live values has been captured and the shaft calibration position and the clearance have been set.

Save click this button to save the changes to the database. Note that to see the new calibration position live in the SCL graph, allow up to 30 seconds (until the device reboots with the new calibration factors).

Machine Parts

Different machine parts can be combined to create a machine or a sub machine. With the help of Machine parts tool, models of machines can be created including shafts, gear boxes, engines, fan casings, blades, generators, etc. The machine parts tool is used to calculate the disturbance frequencies specific to a particular machine, such as gear and bearing frequencies, etc., by using the defined machine data. In this way, the task of finding out which machine component is generating a certain anomaly in the frequency spectra is facilitated. It is possible to go back to the machine parts and edit as often as changes are needed.

Important - The first machine part created should always be a shaft to which the remaining parts are connected.

Important - The speed measurement point must be configured before the running speed can be used.

To get to machine parts screen, perform one of the following options:

- Select a machine from the hierarchy view, then click the right mouse button and choose **Machine parts**.
- Select a machine from the hierarchy view, then click  **Machine parts** icon, on the toolbar.

Creating a Model with Machine Parts

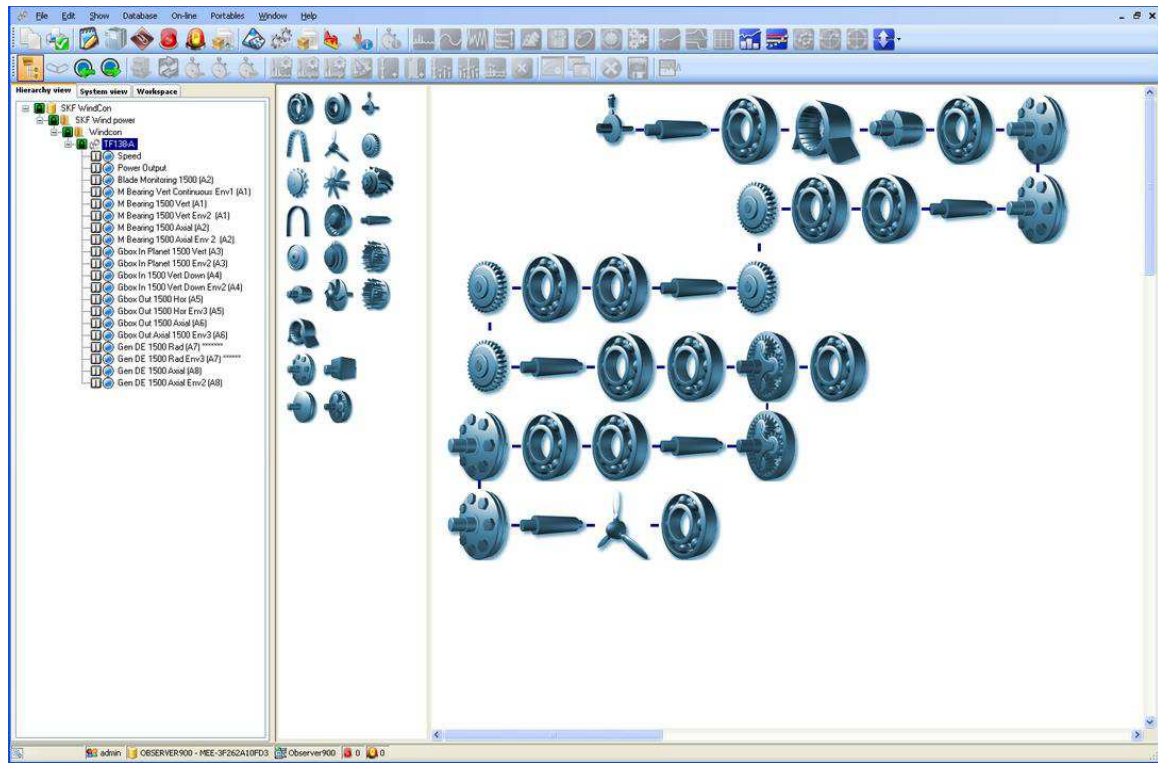

Figure 4 - 65.
Example of Create a Model with Machine Parts.

To create machine parts, perform one of the following options:

- Copying machine parts from another machine is possible. Click on the right mouse button on the blank area of Machine parts' working screen and select **Copy from existing machine**. This will overwrite any existing machine parts with the copied machine parts.
- Simply drag and drop the desired parts from the parts toolbox window to the working area on the right. Dragging and dropping parts close to each other will create a link between them. For example, to link one gear wheel to another, simply drag and drop a wheel on top of the other.

To link the model to the pre-selected machine, drag **speed** from the Parts toolbox window. This speed is used to calculate the defect frequencies for bearings, gears and other parts. In addition, it is also possible to link diagnosis and vibration spectra to the model.

By using **bearing** from the parts toolbox window, a bearing type can be selected from the bearing library. In total a bearing database can hold approximately 30 000 bearings from SKF and a number of other vendors. It is also possible to add new bearings if bearing pitch diameter, roller diameter, number of rollers and contact angle are known.

To add a new bearing to the current machine in the machine parts view:

- Drag the bearing part from the parts toolbox window and drop it into the working area next to the appropriate part of the current machine. This

action creates a link between the added bearing and the appropriate machine part. A **Machine parameters** dialog appears.

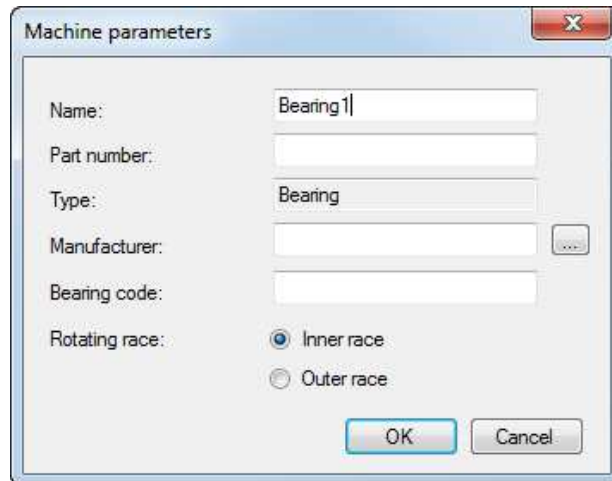

Figure 4 - 66.
Machine Parameters Dialog.

- Enter a unique identifying **Name** for the bearing or keep the default provided.
- Enter a **Part Number** for the bearing.
- Click the browse (ellipsis) button to access the bearing library. There, locate and select the **Manufacturer** and manufacturer's **Bearing code** for the bearing. For more information, see [Bearing Library](#).
- Select whether the bearing **Inner** or **Outer raceway** is **Rotating** in this application.
 - A bearing returns a different cage fault frequency depending on whether the outer raceway is fixed while the inner raceway rotates or the inner is fixed while the outer rotates. Selecting which raceway is rotating allows the cage frequency to be correctly shown when fault frequencies are displayed in spectral diagrams.

The model of the machine created in this way is a schematic illustration and should not be regarded as a scaled CAD (computer aided design) drawing.

Right-clicking on a machine part in the working area provides the following options:

- **Calculate gear** calculates the speed of the selected machine part. This is also done automatically when closing the machine parts window.
- **Delete** deletes the selected machine part.
- **Bring to front** brings the selected machine part to the front of the others when machine parts are staggered on top of each other.
- **Send to back** puts the selected machine part to the back of the others when machine parts are staggered on top of each other.
- **Properties** brings up the properties of the selected machine part and allows its characteristics to be configured.

Right-clicking on the working area provides the following options:

- **Calculate gear** calculates the speed of all the machine parts. This is also done automatically when closing the machine parts window.
- **Copy from existing machine** overwrites existing machine parts, if any, with the selected machine parts or creates machine parts with the selected existing machine.
- **100%, 75%, 50%, 25%** allows zooming of the machine parts window by the selected scale.

Setting up Process Overview

Process overview is a human machine interface (HMI) tool that can be configured to create an easy to use and understand display for control rooms and operators. This display illustrates the current status of the machine through bars and process values.

The process overview is directly linked to the hierarchy, which means that upon opening a machine, all the measurement points on the machine are automatically available. On the top of process overview screen, there is a header displaying the total status of the process overview.

To get to process overview screen, perform one of the following options:

- Select a node, machine or sub machine from the hierarchy view, then click  **Process overview** icon on the toolbar.
- Or, click the right mouse button on a node in the hierarchy view and then select **Process overview**.

Configuration of the Process Overview

To be able to configure the process overview, first set the process overview in edit mode. This is done by right-clicking in the working area and selecting **Edit**

mode or clicking on  **Edit mode** button in the right-hand corner of the process overview screen. To access the following configuration options, right-click in the working area or click a button in the right-hand corner of the process overview screen.



Enterprise Process Overview is the main process overview of the top level of the hierarchy view which includes all databases.



Refresh updates the process overview screen.

Print active window prints the currently opened window.



Back brings back the previous screen.



Up brings to one level up on the hierarchy view.

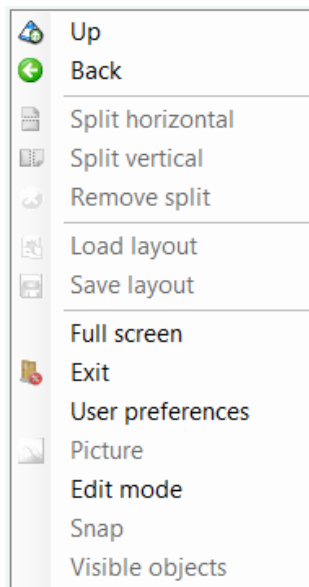

Figure 4 - 67.
Right-click Context Menu.

Split horizontal/Split vertical splits the working area horizontally or vertically. The working area can be split into several different sections. This can be efficient when there are several machines under a specific node and it is desired to browse through them simultaneously. Each time the working area is split, the child or children of the first item of the screen in which the split command was issued, appear in the newly opened screen.

Remove split removes split screen(s).

Load layout loads a layout from the layout list.

Save layout allows a user to save, delete or rename an item from the layout list.



Full screen toggles between full screen mode and partial screen mode.

Exit ends process view.

Log off enables a user with 'Machine Operator Level 1' security role to switch their user type at logon without exiting the application: log off and the **Logon** dialog opens automatically. Log on as a different type of user, such as Admin, to perform tasks requiring different user rights.

User preferences opens the [User Preferences](#) interface for the Process Overview features, where the icon sizes, background and foreground (text) colours can be changed.

Picture exports picture(s) from the pictures list.



Edit mode toggles back and forth between edit mode and non-edit mode.

Snap snaps items to a hidden grid when dragging them.

Visible objects determines which points to display.

Editing a Measurement Point in the Working Area

When in edit mode, the items in the process overview working area can be manipulated by right clicking on an item.

Diagram allows the user to choose an associated diagram to plot.

Properties configures how the measurement point is displayed by editing the following fields.

Name is the name of the selected measurement point which is displayed when choosing Name as Text.

Short name is the user configured name displayed when choosing Short name as Text.

Type is the display type that determines which type to represent the data. The options vary depending on the type of measurement point.

Text determines how the name of the item in the process overview will be displayed.

Name: displays the full length name for the measurement point.

Short name: displays the customised short name for the measurement point.

None: displays no name. Instead, it displays the icon.

Width allows the value of width to be adjusted, instead of changing it with the mouse.

Height allows the value of height to be adjusted, instead of changing it with the mouse.

Show values determines which components of the measurement point should be displayed in graph.

Visible checkbox is used to enable/disable the display of the selected measurement point.

Show EU checkbox shows or hides the engineering units in all the different graph types it is possible to show in the process overview. The default value

is checked, meaning the engineering units are displayed. If the engineering units are hidden, they will still display as mouse over information (a tooltip).

Event Log opens a window with the event log for the selected measurement point.

Machine Copy Wizard

The machine copy wizard is a guide that helps copy an existing machine (with all the machine information) to a new machine.

Note that the wizard cannot overwrite existing channel settings on an existing device. It can however, create a new IMx/MasCon device, so there is no need to create an IMx/MasCon device before launching the wizard.

The following data can be copied:

- Machine specific information
- Machine parts
- IMx/MasCon devices
- Channel configuration
- Online measurement points
- Offline measurement points
- Diagnosis
- Process overview information
- Measurement group

To open the machine copy wizard, perform one of the following options:

- Click the right mouse button on a node in the hierarchy view and select **Add, Machine**, then select **From machine template**.
- Click the right mouse button on a node in the hierarchy view and select **Add, Machine**, then select **Existing machine**.
- Select a machine in the hierarchy view first, then click **Edit** on the toolbar and select **Copy node**.

Using the Machine Copy Wizard

Screen 1, Figure 4 – 68, is Selecting data to copy.

Machine copy wizard

Please select properties for the new machine

Selecting data to copy

Existing machine

Machine name: **Machine**

Machine location: **Observer Database\IMx\Machine**

Destination

New machine name:

New machine code:

New machine location: ...

Data

- Machine parts
- Measurement points
- Process overview
- Device and channel configuration

< Prev. Next > Cancel

Figure 4 - 68.
Example of Data to Copy.

Existing Machine name displays the machine name selected in the Hierarchy view.

Existing Machine location displays the machine location selected in the Hierarchy view.

Destination

New machine name specifies the name for the new machine.

New machine code allows a machine tag or ID number to be entered (optional).

New machine location provides a selection list from the list of nodes in the hierarchy view.

Data

Machine parts check to copy over all the machine parts.

Measurement points check to copy over all the measurement points.

Process overview check to copy over all the data from process overview.

Unit and channel configuration check to copy over all the device and channel configuration data.

Screen 2, Figure 4 – 69, is Measurement points

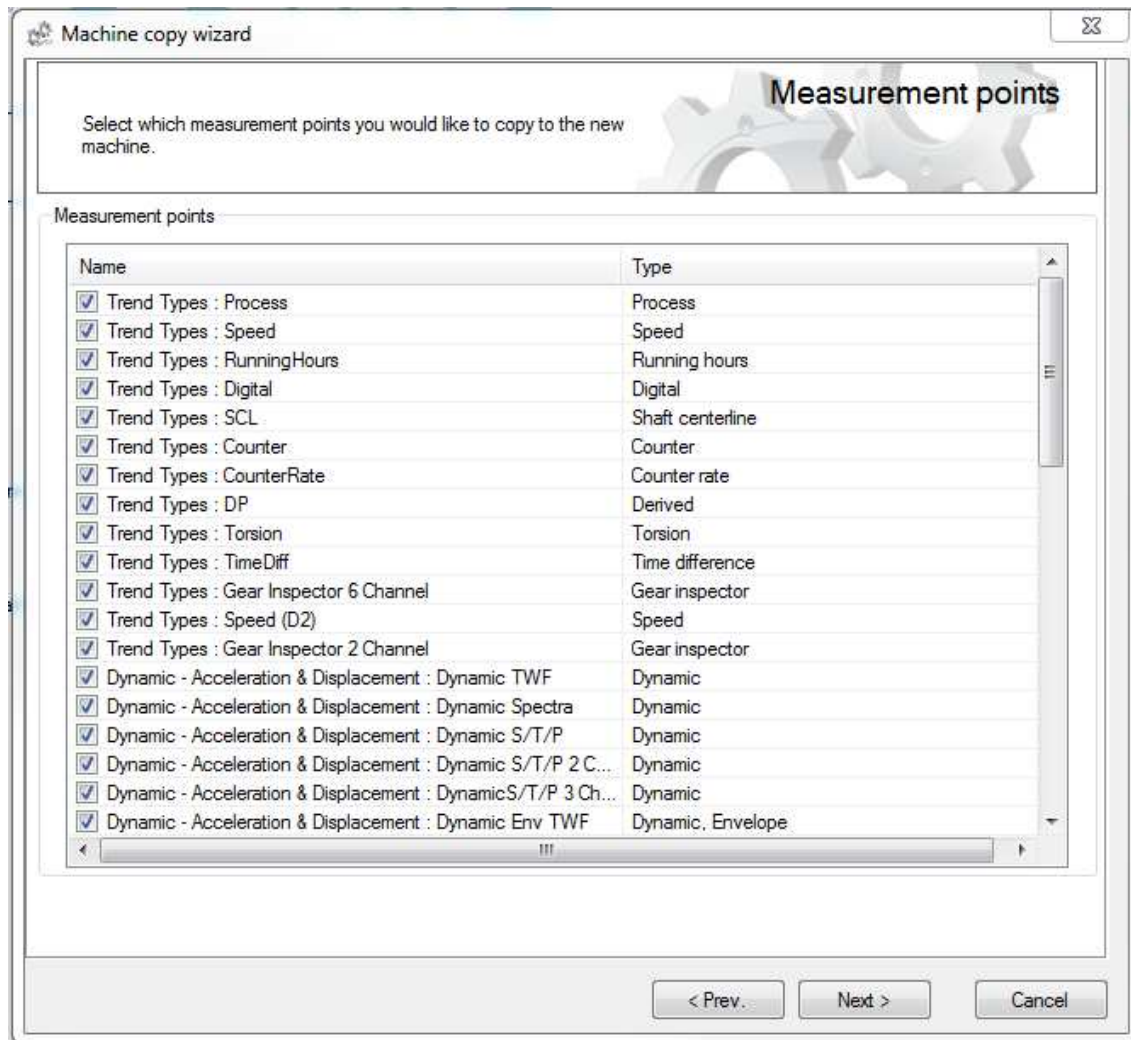

Figure 4 - 69.
Example of Measurement Points to Copy.

The measurement points window shows a list of all the measurement points on the source machine. Select the ones that are to be copied to the new machine. If a measurement point is checked, it will be included in the copy process. Otherwise, it will be excluded from the copy process.

Name displays the name and unique ID of measurement points.

Type displays the type of measurement points.

Select all selects all measurement points in the list.

Unselect all unselects all measurement points in the list.

Screen 3, Figure 4 – 70, is Units and channels

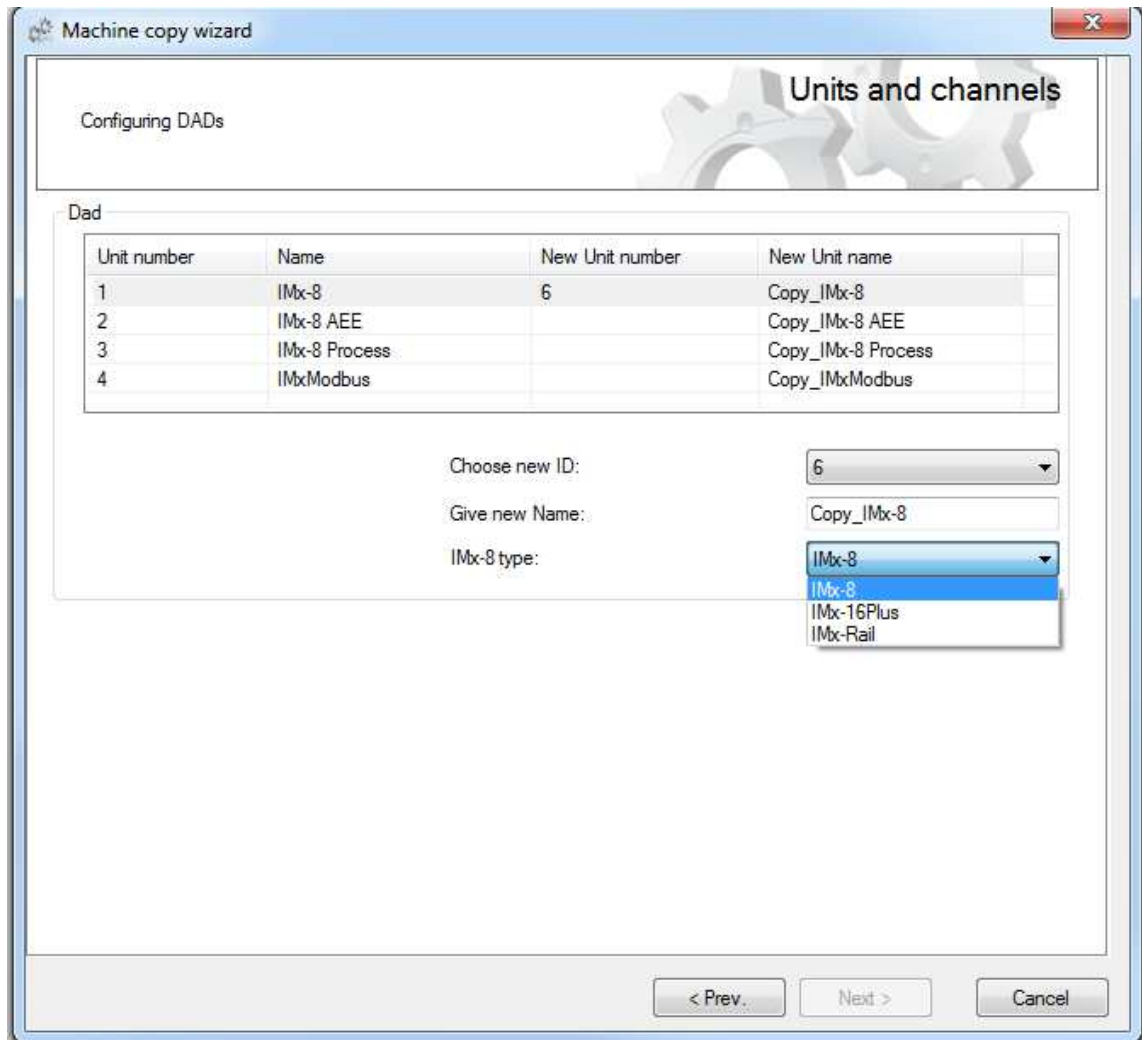

Figure 4 - 70.
Example of Configuring Devices for Machine Copy Wizard.

Based upon the measurement points selected from the previous screen, the wizard gathers all the corresponding information from the IMx/MasCon device and channels.

Unit number displays the unique device number of the selected existing machine.

Name displays the name of the selected machine.

New Unit number is the number selected from the 'Choose new ID' drop-down list, below.

New Unit name reflects the text in the field 'Give new Name', below. This will automatically be given a default 'Copy_' name but can be changed if desired.

IMx-8 type drop-down is active when the existing device is an IMx-8. It reflects the possibility that it cannot just be copied to an IMx-8 but alternatively to (the first 8-channels of) an IMx-16Plus or IMx-Rail device.

- It is not possible to reverse this process (IMx-16Plus or IMx-Rail to IMx-8).

Screen 4 is Finish. Click **Finish** to save the changes made.

Screen 5 is Summary. It displays the details and the summary can be printed.

Example Scenario

There is a wind turbine with one IMx/MasCon system with measurement data. To add a second wind turbine to the @ptitude Observer database, the entire setup of the existing wind turbine can be copied to the new one by using the machine copy wizard. A new device number and name for the new IMx/MasCon device will be requested by the wizard.

Multiple Point Update Wizard

The multiple point update wizard is a tool for updating several measurement points with one or several properties. It can be anything from a simple edit such as changing an active status on a few measurement points in a machine, to more complex edits such as updating a frequency range and number of lines on all IMx/MasCon vibration measurement points in the entire database. The wizard can filter out specific measurement point types based on the selections made.

To open the multiple point update wizard:

- To update a certain set of measurement points:
 1. First select a database, a node, a machine or a sub machine in which these points reside in the hierarchy view.
 2. Click **Edit** on the toolbar, then select **Multiple point update wizard**.
- To update all the measurement points in all the databases:
 - There is no need to select any node. Click on **Edit** on the toolbar, then select **Multiple point update wizard**. In the Wizard, select **All measurement point in all databases**.

Using the Multiple Point Update Wizard

Screen 1, Figure 4 – 71, is Selecting data to modify.

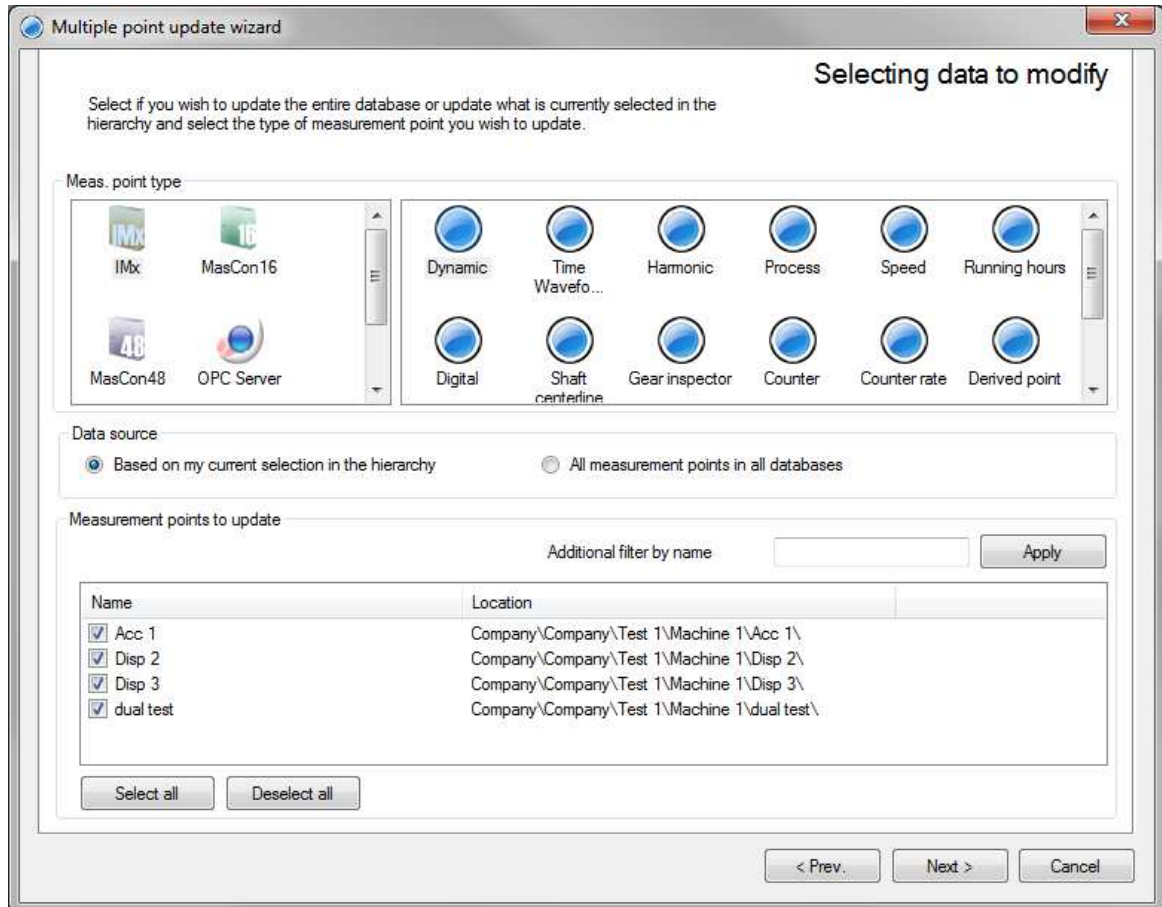

Figure 4 - 71.

Example of Selecting Data for Multiple Point Update Wizard.

Measurement point type enables selection of a type of hardware and then a measurement point type that is to be updated. Only one type of measurement point can be updated at a time.

Data source selects which measurement points in the database, should be updated.

Based on my current selection in the hierarchy: a list of measurement points that were selected in the hierarchy view before entering the Multiple point update wizard screen.

All measurement points in all databases: a list of all the measurement points in all the databases.

Measurement points to update are all the measurement points which can be updated by the wizard. Points can be unchecked, to exclude them from the update.

Additional filter by name enables filtering of the list of measurement points, by a certain name.

Apply applies filtering by the specified name.

- For example, enter “NDE” in the Additional filter by name field and click the **Apply** button, the list of the measurement points will only contain those with name containing the text “NDE”.

Select all selects all measurement points in the list.

Unselect all unselects all measurement points in the list.

Screen 2, Figure 4 – 72, is Attribute selection.

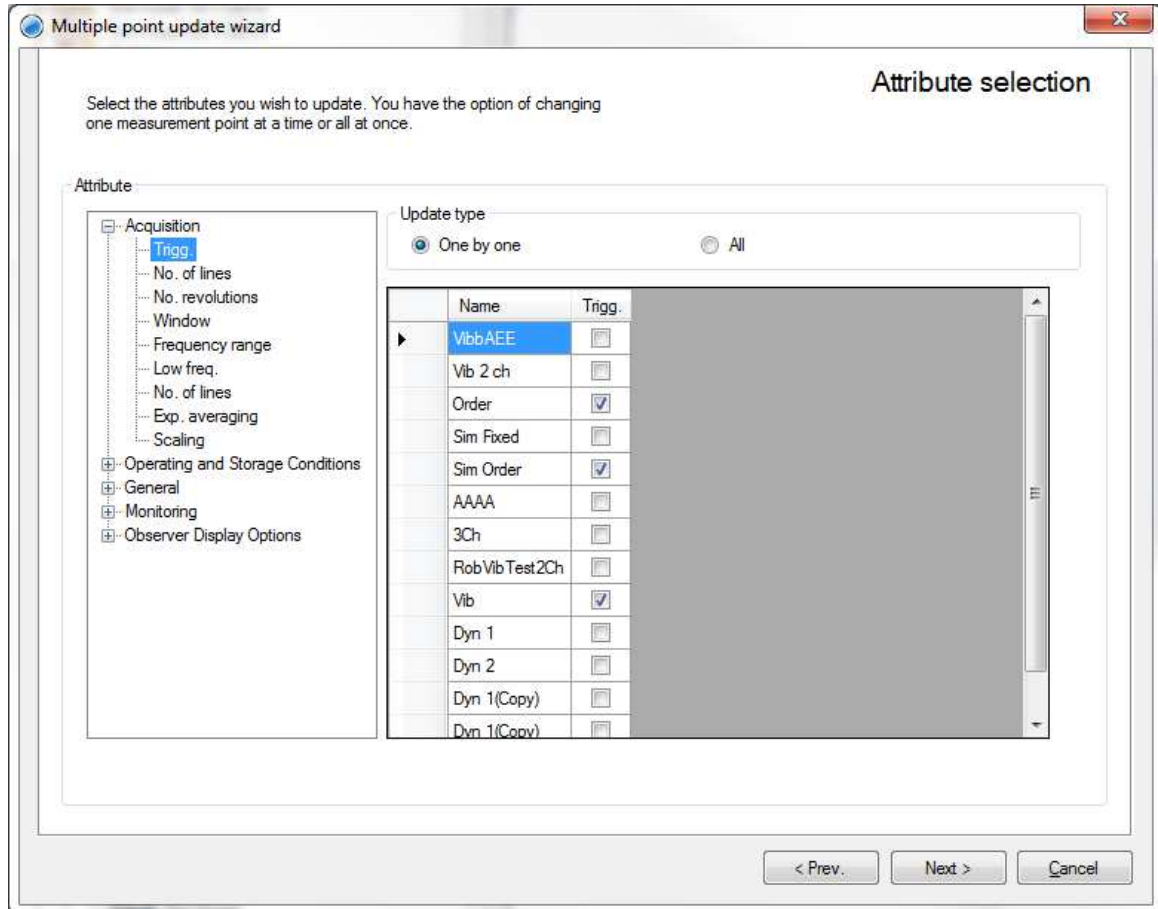

Figure 4 - 72.
Example of Attribute Selection for Multiple Point Update Wizard.

Attribute uses a tree view to select an attribute to update. A list of all the selected measurement points with the current value of the selected attribute is shown on the right side of the screen. The value of the attribute can be changed directly on the list one at a time or all at once.

One by one updates only the current measurement point being edited.

All updates all the measurement points with the edited value.

Screen 3 is Finish. This is the final confirmation to proceed with updating measurement points.

After clicking **Finish**, the wizard starts saving the configuration and any changes made cannot be undone.

Screen 4 is Summary. This provides a list of how many measurement points were updated and how many measurement points could not be updated. If there were any measurement points that could not be updated, the reasons are stated in the Details section.

Startup View

@ptitude Observer remembers each user's departure view so that each session starts from where the previous session ended. For a new user, after a successful logon, @ptitude Observer will start with the hierarchy view in the tree view window as the default view.

Tree View

Tree view window consists of the following types of user interfaces.

[Hierarchy View](#) shows machines and their measurement points in a tree structured hierarchy with the corresponding status for each object. The hierarchy can display data from several databases at the same time.

[System View](#) shows the status from a hardware point of view which is based on IMx/MasCon devices, sensors and measurement points. It shows the communication status as well.

[Workspace](#) is the hierarchy view of user selected machine(s). It is an individual work space to keep track of only the machines for which the user is responsible. A workspace can only span over one single database.

[Diagram View](#) is the hierarchy view of all the saved settings of graphic diagrams including selection of measurement points as well as buffer settings. This is to be able to have predefined views of the data.

Hierarchy View

To get to the hierarchy view screen:

- Click **Show** on the toolbar and then select **Tree view** to open the tree view window.
- Select **Hierarchy view**.
 - If the tree view window has been opened already, select **Hierarchy view** directly from the tree view window.

The hierarchy view displays each object's status with small icons. Status indication/level is inherited upwards in the hierarchy view. For example, if a measurement point on a machine has an alarm status, all the levels above this machine will also be upgraded to an alarm status. The status in the hierarchy view is updated each time a trend is stored in the database by @ptitude Observer Monitor service.

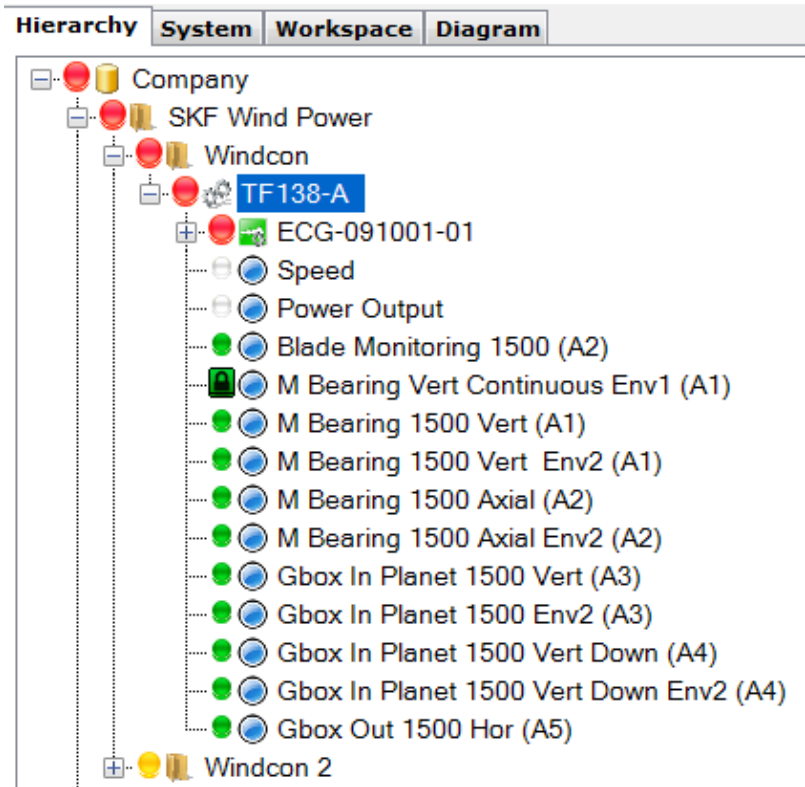

Figure 5 - 1.
Example of @ptitude Observer hierarchy view.

Status in the Hierarchy View



Unknown indicates that the measurement point data is missing and the system is unable to determine the condition of the machine. This is the default status for new measurement points.



Not active indicates that the measurement point is disabled and is on hold. No data will be collected for this measurement point.



Cable fault indicates that the IMx/MasCon device has detected a cable fault on the channel that this measurement point uses. The detection is achieved by bias ranges that are set in the cable check field under the setting analogue channels section for IMx/MasCon devices.



Outside measurement range indicates that the values coming from this measurement point are outside of the acceptance range. The bias on the channel is Ok but the produced values are too high or too low. The measurement range is set in the active range condition field with minimum and maximum values of the trend settings of measurement points.



Alarm indicates that this measurement point has received values that triggered an alarm. The values can be High alarms, Low alarms, Relation alarms or Vector alarms. The alarm status can be confirmed by acknowledging the alarm from the alarm list (refer to [Alarm list](#) under Show in Menu Items section). After the alarm has been acknowledged and new data has been stored in the database, the measurement point will release the alarm status.



Diagnosis alarm indicates that an alarm has been raised by the built-in intelligent machine diagnostics of the system. The rules and logic of the diagnosis alarm can be defined in the diagnosis settings section of setting up measurement points and alarms. Alarm levels for the diagnosis are easily set in the diagnosis trend plot (refer to [Diagnosis](#) under Graphic Displays and Tools in System Operation).



Diagnosis warning indicates that a warning has been raised by the built-in intelligent machine diagnostics of the system. The rules and logic of the diagnosis warning can be defined in the diagnosis settings section of setting up measurement points and alarms. Warning levels for the diagnosis are easily set in the diagnosis trend plot (refer to [Diagnosis](#) under Graphic Displays and Tools in System Operation).



Protean indicates that the built-in machine learning has detected a Protean diagnosis change and the system has generated an alarm. All rules and levels for Protean triggering are determined based on machine learning algorithms developed by SKF and the Protean graph can display the history.



Warning indicates that this measurement point has received values that triggered a warning. A warning is a pre-state prior to alarm which can be High warning, Low warning or Vector warning. The warning status can be confirmed by acknowledging the warning in the alarm list (refer to [Alarm list](#) under Show in

Menu Items). After the warning has been acknowledged and new data has been stored in the database, the measurement point will release the warning status.



Not measured indicates that data has not been measured and stored for the measurement in the time frame the system expected it to be. The time frame is typically double the storage interval for trend. The system is unable to determine the condition of the machine.



Outside active range indicates that the conditions specified by active ranges on the measurement point are not met by the system. One or more active ranges can be configured on measurement points in the spectra settings and trend settings.



Outside active range unstable indicates that not only are the conditions specified by active ranges on the measurement point not met by the system but the measurement is varying too much and triggers the maximum allowed delta value of the active range making it unstable.



Transient indicates that the measurement point is in transient mode which means that a run-up or coast-down is currently occurring. Once the run-up or coast-down of the machine is completed the machine will release the transient status.



No alarm levels set indicates that the measurement point is active and measurement data is coming in but there are no configured alarm levels for the system. The system cannot determine whether the status of the measurement point is acceptable or not.



Ok indicates that the measurement point has no known problems. Data coming in is valid and resides within the specified active range and measurement range. Alarm levels are specified for the measurement point and the data is within the specified alarm and warning levels.

Priority List of Status

An object in the hierarchy view can have several different states. In such case, the status with the highest priority is shown in the hierarchy view.

The following is the list of **Priority Order for measurement points**:

1. Not active
2. Cable fault
3. Outside measurement range
4. Alarm
5. Diagnosis alarm
6. Protean diagnoses
7. Warning
8. Diagnosis warning
9. Not measured
10. Outside active range unstable
11. Outside active range
12. Transient
13. No alarm levels set
14. Ok

The following is the list of **Priority Order for all the others such as a database, node, machine and sub machine:**

1. Alarm
2. Diagnosis alarm
3. Warning
4. Diagnosis warning
5. Cable fault
6. Outside measurement range
7. Not measured
8. Transient
9. Outside active range unstable
10. Outside active range
11. OK
12. No alarm levels set
13. Not active

Configuration Mode Indicators

The nodes in the database can have different configuration mode indicators set depending on the validity of the current node or if the configuration of the specific node or measurement point is not set by the @ptitude Observer software. If there is a configuration mode indicator set for a node or measurement point the normal icon displayed for the node will be replaced by one of the following icons:



Obsolete indicates that this node or measurement point is obsolete and is no longer valid for capturing data. The Observer system can set nodes to this status when nodes need to be retained in the system because they contain measurement data that can be analysed but the conditions of the system has changed in such a way that the specific node is no longer valid to capture data with. If an Obsoleted node is no longer needed, the user can choose to delete the node and its data permanently.

Interfaces Available on Database Level

These functions are accessible by right-clicking on a database.

Add adds a node or a machine. Refer to Node or Machine under Building a Hierarchy View in System Configuration section.

Process overview enables the creation of user defined mimic displays with measurement points and links to other displays overlaid on graphic pictures like drawings, digital photos, etc. Refer to [Process Overview](#) in System Configuration section.

Report generates documents that contain text based information as well as diagrams and pictures of selected data. Refer to [Report](#) under File in Menu Items.

Event log displays all the events of IMx-R devices in the specified database. Refer to [Event Log](#) under On-line in Menu Items.

Configure enables configuration of the following functions for the selected database.

- Reset automatic alarm levels for trend
- Reset automatic alarm levels for diagnosis
- Recalculate diagnoses
- Disable all measurement points
- Enable all measurement points

Block alarm on all measurement points

Remove alarm blocking on all measurement points

Tools enables a user to configure the following settings.

Update graph settings of many measurement points at the same time for the database.

Refresh updates the current hierarchy view with the new status, if any.

Properties allows editing of the properties of the selected database.

Interfaces Available on Node Level

These are accessible by right-clicking on a node.

Add adds a node or a machine. Refer to [Node](#) or [Machine](#) under Building a Hierarchy View in System Configuration section.

Process overview enables the creation of user defined mimic displays with measurement points and links to other displays overlaid on graphic pictures like drawings, digital photos, etc. Refer to [Process Overview](#) in System Configuration section.

Report generates documents that contain text based information as well as diagrams and pictures of selected data. Refer to [Report](#) under File in Menu Items.

Event log displays all the events of the selected node of an IMx-R device. Refer to [Event Log](#) under On-line in Menu Items.

Delete deletes the selected node.

Configure enables configuration of the following functions for the selected node.

Reset automatic alarm levels for trend

Reset automatic alarm levels for diagnosis

Recalculate diagnoses

Disable all measurement points

Enable all measurement points

Block alarm on all measurement points

Remove alarm blocking on all measurement points

Tools enables a user to configure the following settings.

Update graph settings of many measurement points at the same time for the current selection in the hierarchy.

Refresh updates the current hierarchy view with the new status, if any.

Properties allows editing of the properties of the selected node.

Interfaces Available on Machine Level

These are accessible by right-clicking on a machine.

Add adds a measurement point, a sub machine or an event capture group. Refer to [Meas. Points](#) or [Sub Machine](#) under Building a Hierarchy View in the System Configuration section. Refer to [Configuring an Event Capture Group](#) under Database > **Measurement Groups** in the Menu Items section.

Process overview enables the creation of user defined mimic displays with measurement points and links to other displays overlaid on graphic pictures like drawings, digital photos, etc. Refer to [Process Overview](#) in System Configuration section.

Machine parts enables a model of a machine to be built by combining different machine parts. Refer to [Defining Machine Parts](#) in System Configuration.

Report generates documents that contain text based information as well as diagrams and pictures of selected data. Refer to [Report](#) under File in Menu Items section.

Runout Compensation captures runout compensation data for the specific machine. Refer to [Runout Compensation](#) under Setting up Measurement Points and Alarms in System Configuration section.

Event log displays all the events of the selected machine for an IMx-R device. Refer to [Event Log](#) under On-line in Menu Items.

Maintenance planner keeps track of maintenance tasks. Refer to [Maintenance Planner](#) in System Operation section.

Copy copies the selected machine. Refer to [Machine Copy Wizard](#) in System Configuration section.

Paste pastes the copied sub machine or a measurement point, in the selected machine.

Delete deletes the selected machine.

- If the machine being deleted includes points referenced by a Multiple Gating Point, the system will remove those references.
- If the machine being deleted includes an event capture group, the system will remove the group and its related measurement points.

Tools enables a user to configure the following settings.

Update graph settings of many measurement points at the same time based on the current selection in the hierarchy or for the database.

Generate machine template opens a dialog for generating a Machine template of the selected machine.

Configure enables configuration of the following functions for the selected machine.

- Reset automatic alarm levels for trend
- Reset automatic alarm levels for diagnosis
- Recalculate diagnoses
- Disable all measurement points
- Enable all measurement points
- Block alarm on all measurement points
- Remove alarm blocking on all measurement points

Add note adds a note for the selected machine or sub machine. Refer to [Notes](#) in System Operation section.

Calibrate shaft centerline graph connects to the IMx device and retrieves live values for the shaft centerline measurement point and gets data of the current location of the shaft. Refer to [Calibrating Shaft Centerline Graph](#) in System Configuration section.

Add event case adds a document report, information and history regarding a specific event tied to the selected machine. Refer to [Event Cases](#) in System Operation section.

Add attachment attaches any file to the selected machine. Refer to [Machine Properties](#) under Creating IMx/MasCon Devices and Channels.

Tag categorises the selected machine with a specifically defined tag from the [Tag Library](#).

Refresh updates the current hierarchy view with the new status, if any.

Properties allows editing of the properties of the selected machine.

Interfaces Available on Sub Machine Level

These are accessible by right-clicking on a sub machine.

Add adds a measurement point. Refer to [Meas. Points](#) under Building a Hierarchy View in System Configuration section.

Process overview enables the creation of user defined mimic displays with measurement points and links to other displays overlaid on graphic pictures like drawings, digital photos, etc. Refer to [Process Overview](#) in System Configuration section.

Report generates documents that contain text based information as well as diagrams and pictures of selected data. Refer to [Report](#) under File in Menu Items section.

Event log displays all the events of the selected sub machine for an IMx-R device. Refer to [Event Log](#) under On-line in Menu Items.

Copy enables copying of the selected sub machine to a new location directly.

Paste pastes a copied measurement point into the selected sub machine.

Delete deletes the selected sub machine.

- If the sub machine being deleted includes points referenced by a Multiple Gating Point, the system will remove those references.

Trend automatic alarm levels for the selected sub machine.

Diagnose automatic alarm levels for the selected sub machine.

Recalculate diagnoses for the selected sub machine.

Update graph settings of many measurement points at the same time for the selected sub machine.

Add note adds a note for the selected machine or sub machine. Refer to [Notes](#) in System Operation section.

Calibrate shaft centerline graph connects to the IMx device and retrieves live values for the shaft centerline measurement point and gets data of the current location of the shaft. Refer to [Calibrating Shaft Centerline Graph](#) in System Configuration section.

Tag categorises the selected sub machine with a specifically defined tag from the [Tag Library](#)

Refresh updates the current hierarchy view with the new status, if any.

Properties allows editing of the properties of the selected sub machine.

Interfaces Available on Meas. Point level

These are accessible by right-clicking on a measurement point.

Diagram to select and access a graphical display of the measurement point data.

Report generates documents that contain text based information as well as diagrams and pictures of selected data. Refer to [Report](#) under File in Menu Items section.

Event log displays all the events of the selected measurement point for an IMx-R device. Refer to [Event Log](#) under On-line in Menu Items.

Copy the selected measurement point.

Paste the copied measurement point to a new location.

Delete the selected measurement point.

- If the point being deleted is referenced by a Multiple Gating Point, the system will remove that reference.

Reset automatic alarm levels for trend for the selected measurement point.

Reset automatic alarm levels for diagnosis for the selected measurement point.

Recalculate diagnoses of the selected measurement point.

Add note for the selected measurement point. Refer to [Notes](#) in System Operation section.

Tag categorises the selected measurement point with a specifically defined tag from the [Tag Library](#)

Refresh the current hierarchy view with the new status, if any.

Properties to edit the properties of the selected measurement point.

System View

The System view shows the database from the system point of view with IMx/MasCon devices, sensors/channels and measurement points.

To access the system view screen:

- Click **Show** on the toolbar and then select **System**.
- If the tree view window has been opened already, select **System** directly from the tree view window.

Figure 5 - 2 below, is an example of a system view.

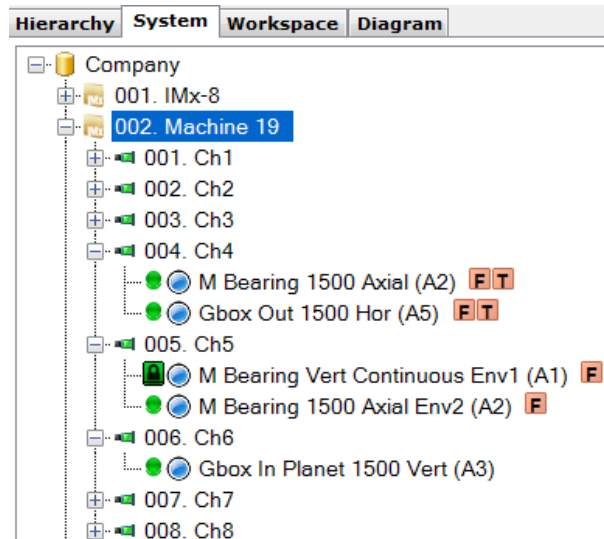

Figure 5 - 2.
Example of System View.

By right-clicking on a database, node, machine, channel and measurement point, there are options to **Refresh** data or open the **Property** settings of the selected node and edit.

By right-clicking on a measurement point, there are also options to open a graphic display **Diagram** to edit, **Delete** the selected measurement point or set a **Tag** on the measurement point.

Workspace

The Workspace is an individual work space consisting of user selected machines' hierarchy view. It is used to keep track of only machines for which the user is responsible. Note that a workspace cannot span several databases.

To open Workspace screen:

- Click **Show** on the toolbar and then select **Workspace**.
- If the tree view window has been opened already, select **Workspace** directly from the tree view window.

Figure 5 - 3 below, is an example of a Workspace.

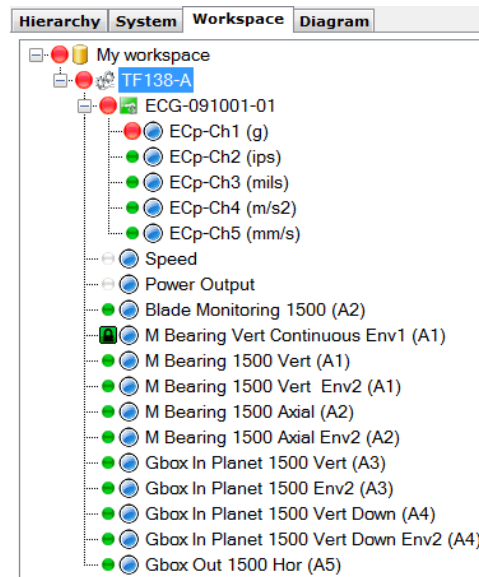

Figure 5 - 3.
Example of Workspace.

To configure a workspace, select **Workspace** from the **Edit** menu. Refer to [Workspace](#) under Edit, in Menu Items section.

Diagram View

The Diagram view is a list of saved [diagram boxes](#). Diagram boxes are predefined views of the data which contain specified graphic settings including selection of measurement points as well as buffer settings.

To open Diagram screen:

- Click **Show** on the toolbar and then select **Diagram view**.
- If the tree view window has been opened already, select **Diagram** directly from the tree view window.

Figure 5 - 4 below, is an example of a Diagram view.

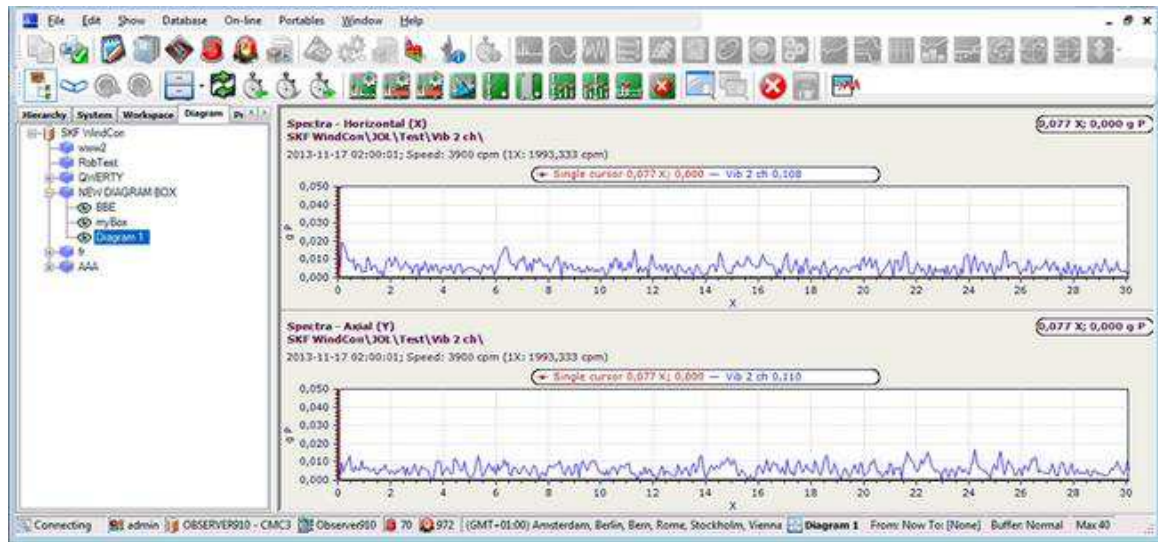

Figure 5 - 4.
Example of Diagram View.

To bring up the graphic display with the saved settings, double click on a selected diagram box.

Graphic Displays and Tools

There are many graphical displays available in @ptitude Observer to facilitate data analysis. The accessibility of graphical displays depends on the selected item.

To access a graphic display screen:

1. First select a measurement point, a sub machine or a machine in the hierarchy view, system view or workspace.
2. Select one of the following graphic display icons on the toolbar. Alternatively, if a measurement point has been selected, right click on the measurement point then click **Diagram** and choose a graphic display.



Graphic Features

Multi-point analysis is possible in most displays by dragging and dropping more measurement points onto the same graph. Holding [**ctrl key**] down while releasing a measurement point on a graph adds the measurement point on the display overlaying the data if the graph supports it.

Legend is included in all displays and gives information on selected values, cursor positions, type of data and more. Legend can be repositioned and enabled in all graphs. It can be enabled by checking the Visible field. It also has an option to have display positioned at Top, Bottom, Left or Right of a graph.

Buffer setting sets the depth and conditions on which data to retrieve and display in the graphs. The access to buffer setting can be done by clicking on the buffer icon on the toolbar after opening a graph. The graph will be updated with the new data from the buffer settings automatically. Refer to [Buffer](#) in System Operation.

Graph Settings

To access graphic settings:

- Click on the right mouse button on the graphic display screen, then select an option from the pop-up menu.

- It is also possible to update graphic settings of many measurement points at the same time by **right-clicking on a node or a machine** in the hierarchy view, then selecting **Tools** and then **Update graph settings**.

Some edited graph settings can be saved on the measurement point while the others are only temporary changes. When certain settings are modified within any one of the following graph types for a single point, the system will automatically save the modifications as the preferred settings for that graph and point. The next time the user accesses the same graph for the same point, the graph will retain any applicable preferences that have been set.

Graph types that save preferences/modifications include:

- Multi-Trend
- Orbit
- Shaft Centerline
- Spectra
- Time Waveform
- Trend

Graph settings that will be saved, where applicable, for the above graphs (specifically, graph type/point type pairs) include the following:

Direction	Legend Visible/Alignment	Show phase
Display style	Line style	Start/stop markers
Frequency unit	Mode	Title Checkboxes
Invert rotation direction	Set speed	X axis
Invert view position	Shaft cycle time	Y axis

3D settings enable editing of zoom, rotation and elevation scales for 3D plots.

Add cursor adds available cursors (markers) one at a time in the graph temporarily. Descriptions of available cursors can be found in Tools for Graph Display section below.

Alarm circles hides/shows alarm circles for polar types of plots. One warning circle (yellow) and one alarm circle (red) is drawn.

Annotations can be added as temporary notes for the current graph. They can be useful for printouts of the current graph or screenshots. To add an annotation, right-click on the graph and select the menu item **Annotation/Add**. A text box appears on the top left corner. To edit the text in the text box, double click the text box. To end editing, click the ESC key on the keyboard. Click the mouse and drag the annotation where it is to be placed.

Auto alarm is available for diagnosis display only. It is based on the data in the graph which configures the alarm settings for the built-in intelligent diagnostic system.

Copy is available on all graphs in @ptitude Observer. It creates a screenshot of the graph and copies it to the clipboard.

Correlation tolerance is available for the multi trend plot only. Correlation tolerance sets a tolerance for how far apart correlated measurements can be and still be displayed. Can be set to Exact or in a range from 1 second up to 1 hour.

Curve fitting applies an approximation of a curve fit to the data currently displayed in the plot. Options are 1st Degree, 2nd Degree, 3rd Degree and None.

DiagX brings up a list of machine parts and the probability for each being related to the selected frequency. This edit is temporary. See **DiagX** in Tools for Graph Display below.

Exclude from diagnosis calculation excludes an FFT from diagnosis.

Export is available on all graphs in @ptitude Observer. It brings up an **Export** dialog where data can be selected for export in several different formats, including as Excel and text files.

Frequency unit switches the frequency unit between Hz, cpm and Order. The change made to frequency unit can be saved on the measurement point.

Fault frequencies brings up a dialog where the user can choose machine parts from the machine that the user is currently analysing. When one or more machine parts are selected, the frequencies for them are drawn in the graph. In this way, the user can clearly see which of the machine parts maybe causing high readings. The frequencies displayed for the machine parts are automatically calculated using the running speed.

Go to [Double click] for diagnosis display, toggle back and forth between the main diagnosis screen and the one graph selected. **Go to [Double click]** for history display to open the selected history in full screen mode.

Inverted changes the sign of all data in the plot.

Legend sets the preferred position of the legend. Refer to [Graphic Features](#) for detailed information. A general position of legend can be set for all graph displays at [User Preferences](#) under Edit in Main Item.

Line style specifies the style of line to graph temporarily. The available line styles are Line, Point and Line and point.

Listen to time waveform enables 'playback' of the [time waveform](#) if there is a sound card installed in the computer.

Markers allows markers to be added by **[shift+click]** or the nearest marker to be removed (temporarily) by **[ctrl+click]**.

Max scale provides a list of pre-defined maximum scale settings to select temporarily. Selecting auto will cause the system to select the most appropriate maximum scale setting for the current data.

Min scale provides a list of pre-defined minimum scale settings to select temporarily. Selecting auto will cause the system to select the most appropriate minimum scale setting for the current data.

Mode is available for history graphic display only. Mode temporarily switches between spectra, time waveform, phase, spectra/time waveform and spectra/time waveform/phase.

Noise reduction sets the noise reduction level in percentage.

Palette steps is available for gear inspector graphical display only. It indicates the total number of different colours used for the display.

Reference stores the current active measurement in the graph as reference data for the active measurement point or clears the existing reference data. When setting a measurement as a reference, the measurement will automatically be set with the Keep forever flag. Keep forever flag can be edited in [Meas. date](#) interface. The reference data is shown in the background of this graph every time data is displayed for this measurement point.

Remove DC provides the option to exclude the DC part of the signal. Often when showing time waveform data, the DC part is removed, leaving just the AC signal content.

Runout compensation is used to avoid that shaft out of roundness, is included as vibration.

Save to Diagram Box saves the current graph settings under an assigned name. For detailed information refer to [Diagram View](#) under Tree View in System Operation.

Scale allows a value selection from the list of pre-defined scale settings. Selecting Auto will cause the system to select the most appropriate scale setting for the currently displayed data. In most graphs, the mouse wheel can be used to increase or decrease the max scale. The change made to scale can be saved on the measurement point.

Scale type switches between Lin (linear) and Log (logarithmic) scale. If Log is selected, then the system will use the number of decades as the scale. Number of decades in logarithmic scale is set in [User Preferences](#) interface under Edit in Menu Items section. The change made to scale type can be saved on the measurement point.

Scaling temporarily changes the display scaling (detection) of the measurement point. Scaling options are peak, PtP (peak to peak) or Rms. The original measurement point scaling is restored when that particular graph is closed.

Sectors is available for gear inspector graphical display only. It indicates the number of gear sectors. The default is 360 which means that there are 360 sectors each 1 degree wide, whereas if 180 was chosen, there are 180 sectors each 2 degrees wide.

Set Speed enables manual adjustment for the speed reading of the current measurement displayed in the Spectra plot.

Shaft is available for profile display only. It can be selected to determine for which shaft the profile should be calculated.

Shaft Cycle time is available for Orbit plot only. Select from Tacho shaft, Order analysis shaft or custom speed.

Show phase is available for trend graphic display only. It brings up the phase graphic display on a split screen.

Show pulses is set by default which displays pulses in the graph. It can be unset if needed.

Show values displays the values in 3D plots.

Start/stop markers hides/shows the start and stop markers for displays. The markers typically show the first and the last value drawn in the graph.

Type selects the type of orbit graph to display.

Unit is the measurement unit of the data displayed which can be changed temporarily. Changes can be made between velocity, acceleration and displacement. The original measurement point units are restored when that particular graph is closed.

X-axis changes the x-axis value to date/time, speed, process or values temporarily. For multi trend plot, it is also possible to set the x-axis to another measurement point which will correlate the measurements of measurement points with each other.

Y-axis changes the y-axis value to amplitude or percent temporarily.

Z-axis is available for 3D plot only. Change the z-axis value to date/time, speed, process or even spreading temporarily.

Zero padding temporarily enables zero padding.

Tools for Graph Display

There are a vast number of tools available in the graphs to facilitate data analysis. The tools appear as green icons located on the toolbar.



Fault frequencies brings up a dialog where a user can choose machine parts from the machine that the user is currently analysing. When one or more machine parts are selected, the frequencies for them are drawn in the graph. In this way, the user can clearly see which of the machine parts maybe causing high readings. The frequencies displayed for the machine parts are automatically calculated based on running speed.



Previous fault frequency moves the active cursor to the previous machine part. **[ctrl+right arrow key]** also moves the active cursor to the previous machine part.



Next Fault frequency moves the active cursor to the next machine part. **[ctrl+left arrow key]** also moves the active cursor to the next machine part.



DiagX is an intelligent part of the built-in diagnostic system. To use it, select a frequency in the graph that looks interesting and click **DiagX** button. A dialog will appear listing all the machine parts and the probability that the selected frequency including harmonics belong to a specific machine part. It is an easy way to find out which part of the machine causes a high peak at a specific frequency. DiagX feature also works for sideband and band cursors.

- DiagX calculates by how much the selected frequency (including harmonics) deviates from the expected components due to a specific machine part. So, 0% indicates a good match, high probability.



Single cursor adds a single cursor to the graph. Once a single cursor has been added, switch between cursors by clicking on them which makes cursors active. A single cursor can be moved with the **[left arrow key]** or **[right arrow key]**. **[shift+left arrow key]** or **[shift+right arrow key]** causes a cursor to move in bigger steps.

When viewing a trend/spectra plot, this button will activate a secondary cursor on the trend and display a secondary spectrum plot, shown alongside the first (the primary spectrum plot). For further detail, please refer to the section

[Combination plots](#).



Band cursor adds a band cursor to the graph. It allows, by dragging the handles of the band, to position and resize the band freely. A single band cursor can be moved with **[left arrow key]** or **[right arrow key]**. **[shift+left arrow key]** or **[shift+right arrow key]** causes a cursor to move in bigger steps.

A band cursor has three handles at the top of the band:

First handle: makes the band cursor bigger or smaller by clicking and dragging.

Third handle: makes the band cursor bigger or smaller by clicking and dragging.

Middle handle: repositions the band by clicking and dragging.



Harmonics produces a harmonic cursor of the currently selected frequency. This cursor can also be moved with **[shift key]** or **[ctrl key]** in combination with **[left arrow key]** and **[right arrow key]** or by clicking and dragging with the mouse. Harmonic cursors can be between 10 and 200 which can be set in [User Preferences](#) in Edit menu item.



Sidebands inserts a side band marker, marking 5 side bands below and 5 above an X marker. There are two modes of a side band marker:

First mode: is the default mode. X is selected. The arrow keys move the sideband marker but keep its size.

Second mode: is set by selecting -1 to -5 or 1 to 5. The arrow keys now resize the side band cursor.



Amplitude peaks cursor displays the highest peaks in the graph. It consists of a horizontal line stretching across the graph. The horizontal line is movable in the vertical axis by clicking and dragging the line. Peaks found above this line are marked with a number.



Select measurement date selects a start date for the graph. Double clicking on a date refreshes the graph with the data from the selected date.



Clear clears the graph of all tools, cursors and other custom markers that have been added.



Zoom is available on almost all graphs. It zooms in only once at a time. Once the graph has been zoomed in, the graph is no longer in the zoom mode. Zoom mode must be re-instated by clicking the zoom icon each time. Click and drag the mouse to the desired area. It is also possible to scroll the zoomed graph by pressing **[shift key]**, then click and drag.



Zoom out brings a graph back to its original size.



Delete deletes a measurement from the database. Spectra, time waveform and phase are considered as a single measurement, which means that deleting a spectrum will also delete the corresponding time waveform and phase data, if there are any.



Save saves the current live measurement from the graph to the database. The measurement will be marked with the storage reason manual because it was manually saved and not by the time-based schedule.



Live reads data immediately from the measurement point(s) and displays the data in the graph. To get live data, a connection to the @ptitude Observer Monitor computer must be established. @ptitude Observer sends a request to @ptitude Observer Monitor which redirects the request to the correct IMx/MasCon device which then collects the data and sends it back through the reverse path.

Spectra



Use this icon to generate spectra display of a selected measurement point. Spectra display shows the vibration amplitude as a function of frequency. Regardless of the input signal type, the amplitude can be shown in acceleration (m/s^2 or g), velocity (mm/s or ips) or displacement (um or $mils$) using a linear or logarithmic amplitude scale. All defect frequencies for the whole machine are automatically calculated and can be easily displayed in a plot as vertical bars.

Harmonics of defect frequencies or any other frequency can be displayed by an automatic fitting function. The spectra can be zoomed easily to any frequency range inside the original spectra. Auto scaling or fixed scales can be applied and the frequency scale can be either Hz, cpm or order.

In addition, spectra display supports the zero padding which can be used to more easily identify specific peaks in the FFT. With a simple right-click, it is possible to set the data currently displayed in this graph as reference data for the future.

Below, Figure 5 – 5, is an example of a spectra display with overlay data.

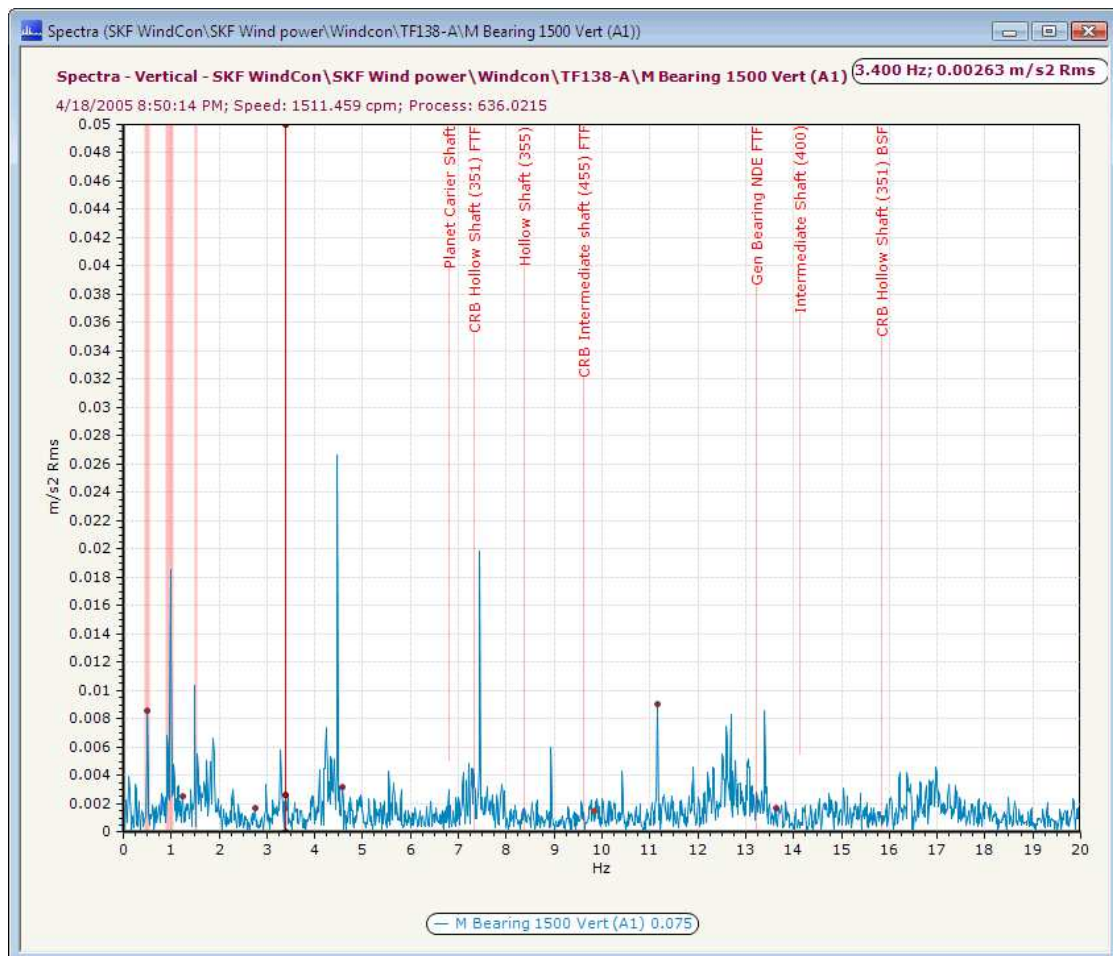

Figure 5 - 5.
Example of Spectra Display.

Full Spectrum

A Full Spectrum provides an enhanced view compared to a Spectrum display. The Full Spectrum is used to display a graph of spectrum data collected from two, orthogonally mounted sensors in a dual channel point.

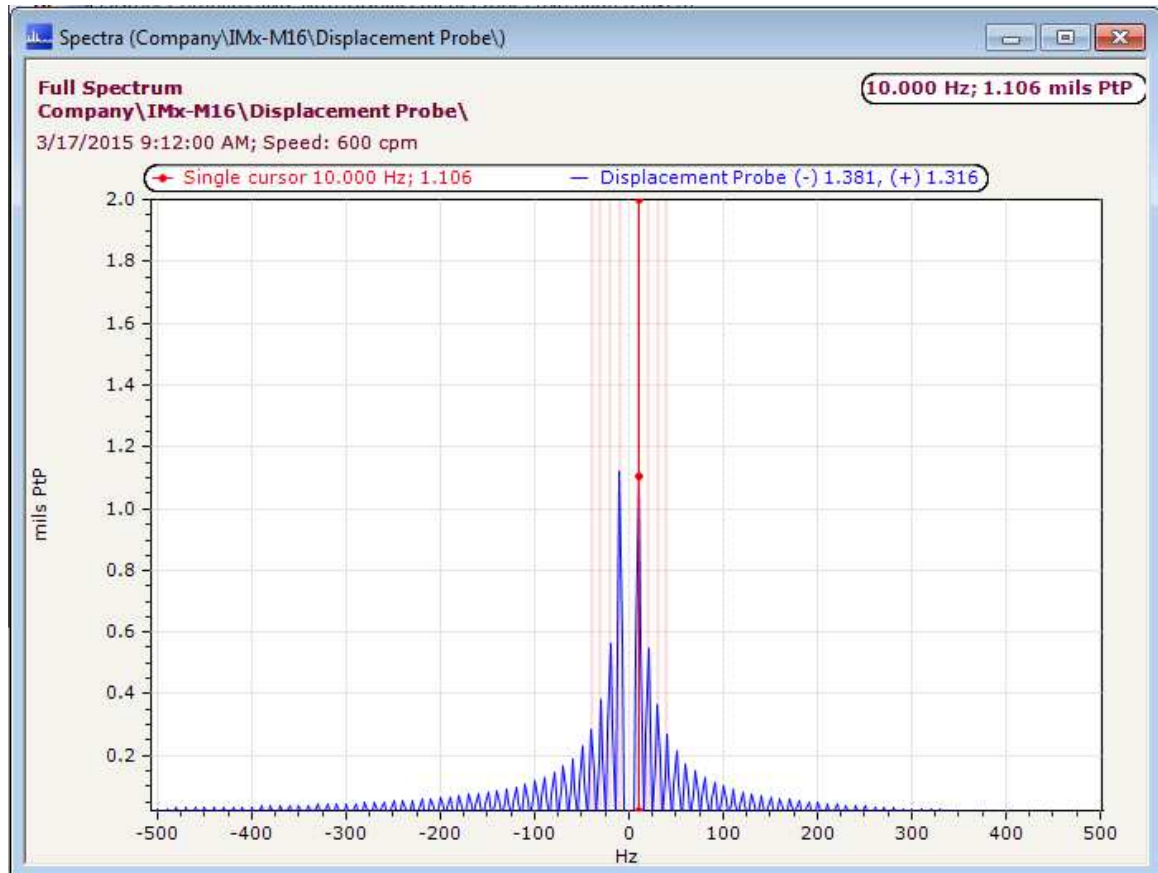

Figure 5 - 6.
Example of Full Spectrum Plot.

Displaying Full Spectrum plot

The **Full Spectrum** is not the default diagram for spectral data. By default, the **Spectrum** is the default, which is displayed by first selecting a point that collects time-waveform data (either **Dynamic** or **Harmonic**), then selecting the **Spectra** menu button or right-clicking the point and selecting **Diagram/Spectra**.

If the user enters the **Edit/User Preferences** menu and selects the **Full Spectrum = True** option, clicking on the **Spectra** menu button or right-clicking the point and selecting **Diagram/Spectra** will launch the **Full Spectrum** assuming the following criteria are met:

- The point has 2 channels
- Time waveform data has been collected.

If these criteria are not met, the normal **Spectrum** is displayed.

The user may also launch the **Full Spectrum** from the **Spectrum** display by right-clicking the plot and selecting **Full Spectrum**. Likewise, the user may launch the **Spectrum** display from the **Full Spectrum**.

Initial Plot description

The horizontal axis represents frequency (in Hz, CPM or Orders). A frequency of zero is central in the plot. Negative values extend to the left and positive to the right. The first four orders of running speed are marked in both the positive and negative directions with light red vertical lines. A single cursor is displayed on the highest amplitude in the positive direction. Scaling is set to automatic.

Option Menu

The Option Menu is displayed when the user right-clicks on the Full Spectrum. All relevant options supported by the Spectrum are also supported for the Full Spectrum plot.

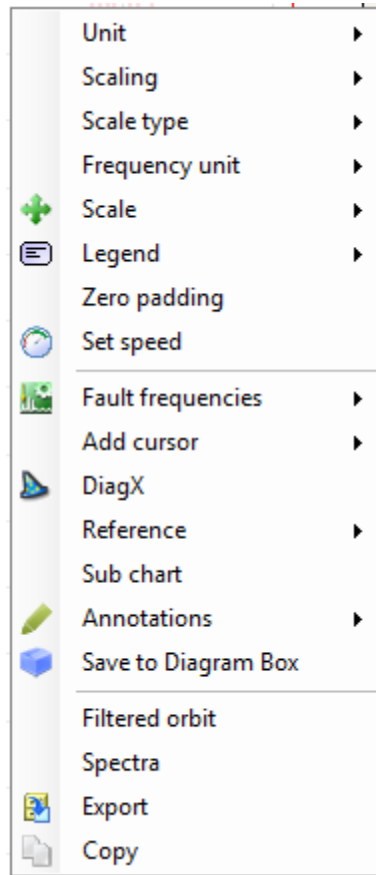

Figure 5 - 7.
Example of Full Spectrum Option Menu.

Time Waveform



Use this icon to generate a time waveform display of a selected measurement. Time waveform display shows the vibration signal against time. Regardless of the signal type the amplitude can be shown in acceleration (m/s^2 or g), velocity (mm/s or ips) or displacement (μm or mils). If the measurement on display is triggered using a digital input, the tachometer pulses are shown automatically making it easier to track each revolution.

The time waveform can be easily zoomed and the scaling can be done automatically or manually.

By a simple right-click on the mouse, the user can listen to the time waveform using the computer speakers and can detect, by listening to the sound of the machine, abnormal sounds. Listen function of time waveform is opened in an external window. Here, speed and length of the time waveform can be modified while listening.

Figure 5 - 8 below, is an example of a time waveform display with tachometer pulse markers and band cursor.

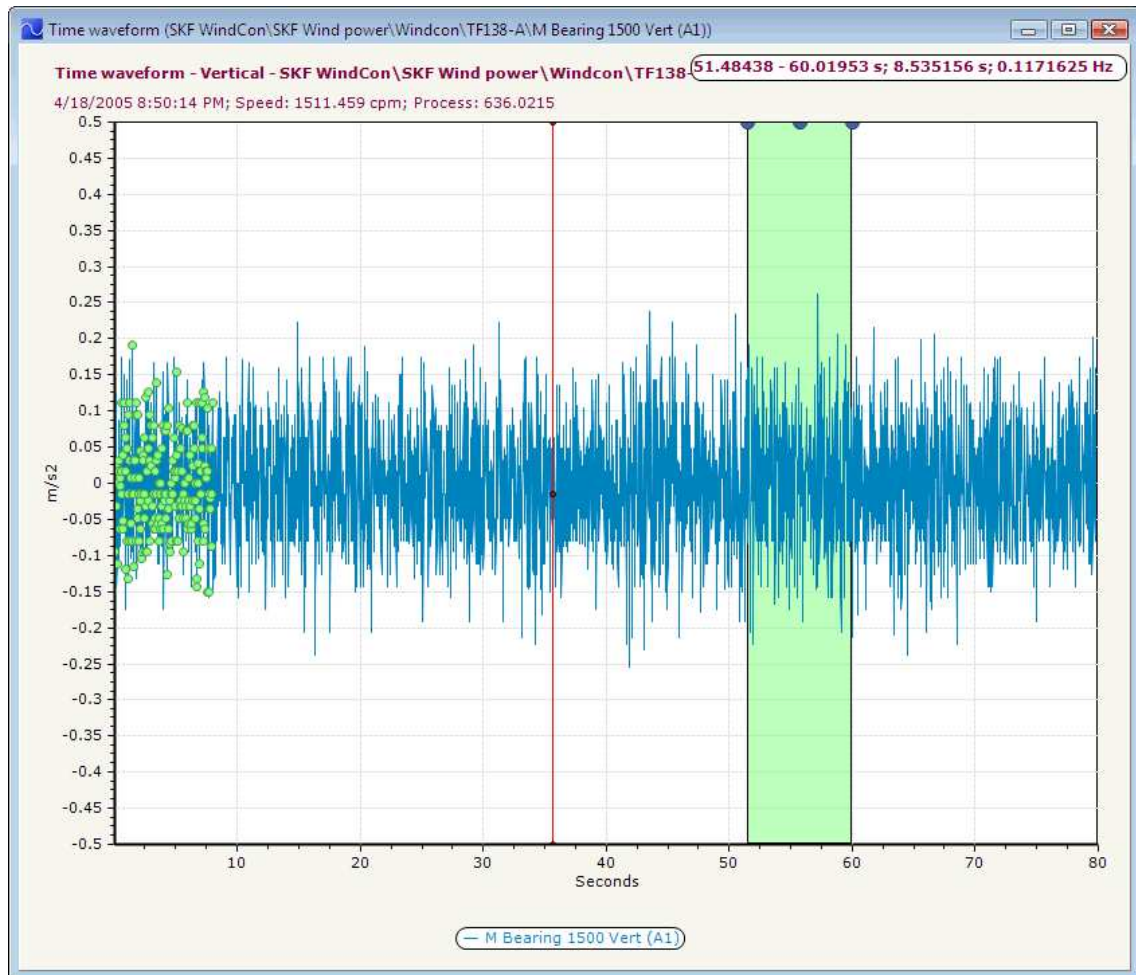

Figure 5 - 8.
Example of Time Waveform Display.

Phase



Use this icon to generate a phase display of a selected measurement point. Phase spectrum shows the phase with respect to the frequency. Combined with the amplitude spectrum, it is easy to get the phase lag for any peak in the vibration spectrum. If multiple points are measured synchronously, it is possible to determine the phase relationship of any peak between two different points, especially if data from different measurement points are overlaid.

As in time waveform display and in spectrum display, the unit can be recalculated on the fly between acceleration, velocity and displacement and can show relative to the frequency in Hz, cpm or order.

The phase can be easily zoomed and the scaling ranges can be between -180 and 180 degrees.

Figure 5 - 9 below, is an example of a phase display.

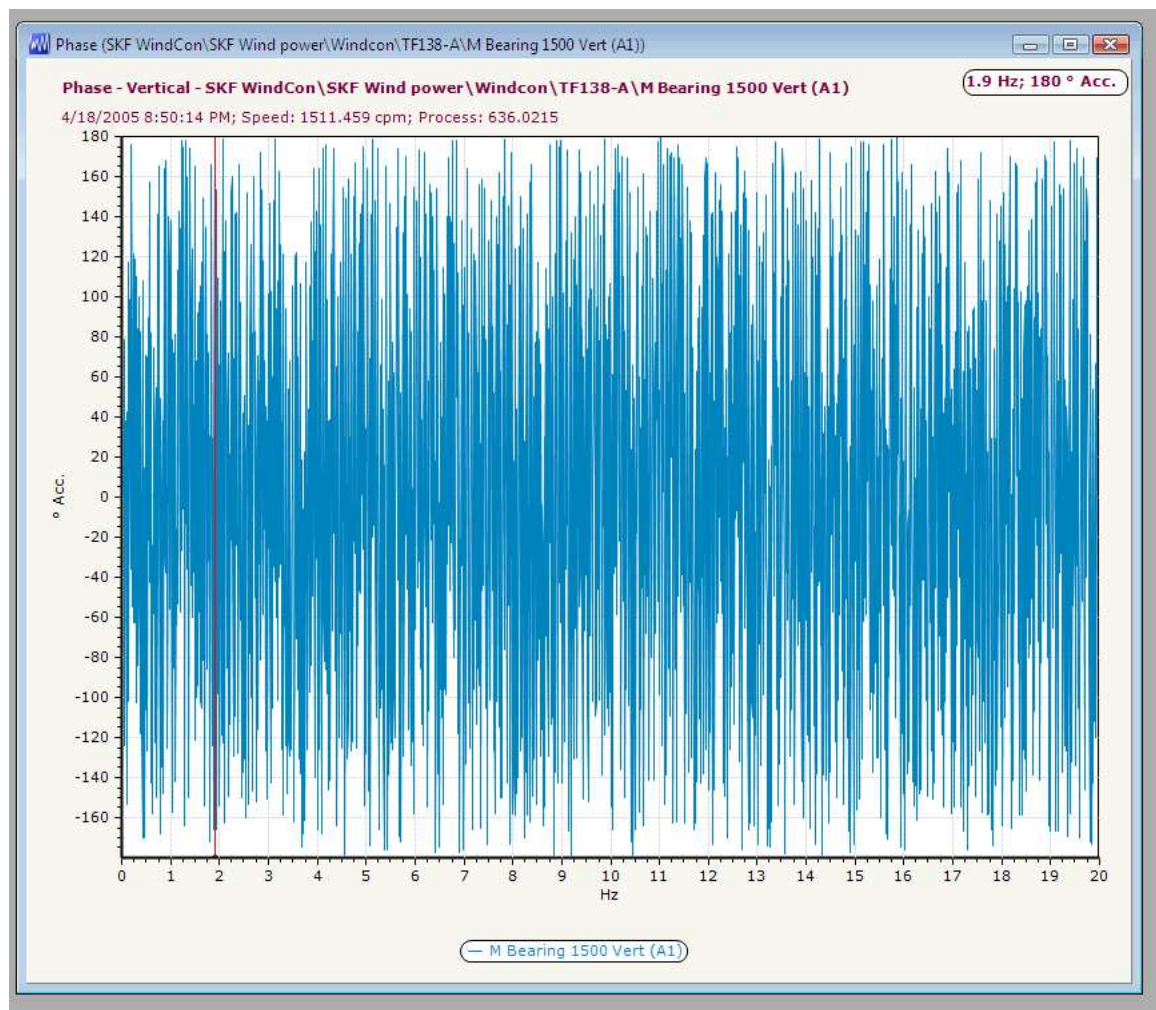

Figure 5 - 9.
Example of Phase Display.

Full Spectrum Phase

Full Spectrum Phase provides an enhanced view of the existing Spectrum Phase. The Full Spectrum Phase is used to display a graph of spectrum data collected from two, orthogonally mounted sensors in a dual channel point.

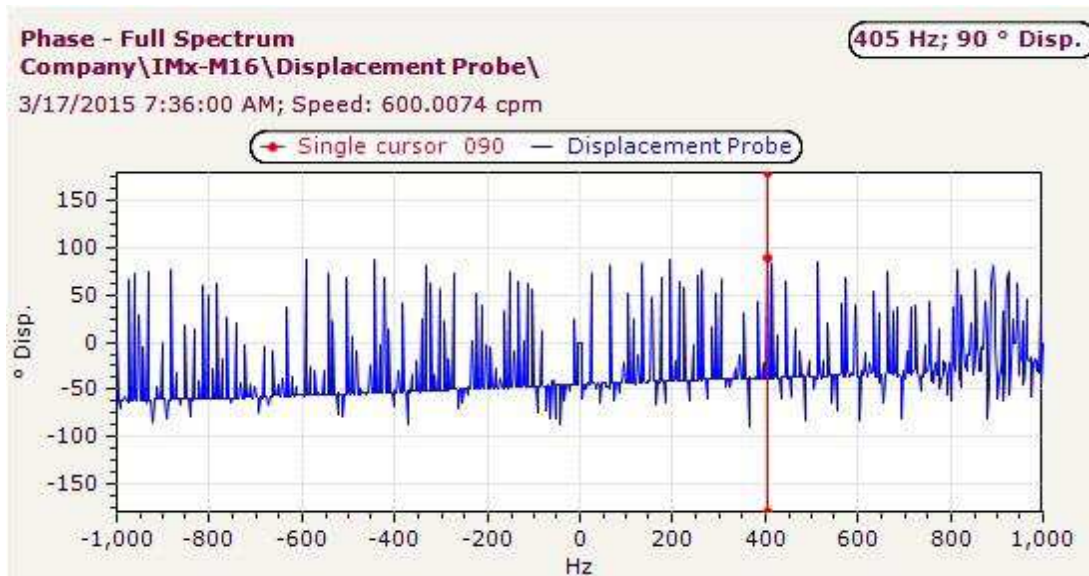

Figure 5 - 10.
Example of Full Spectrum Phase Plot.

Displaying the Full Spectrum Phase

Full Spectrum Phase is not the default diagram for spectral data. By default, the **Spectrum Phase** is the default, which is displayed by first selecting a point that collects time-waveform data (either Dynamic or Harmonic), then selecting the **Phase** menu button.

If the user enters the Edit/User Preferences menu and selects the Full Spectrum = True option, clicking on the Phase menu button or right-clicking the point and selecting **Diagram/Phase** will launch the **Full Spectrum Phase** plot assuming the following criteria are met:

- The point has 2 channels
- Time waveform data has been collected.

If these criteria are not met, the normal Phase is displayed.

Initial Plot description

The horizontal axis represents frequency (in Hz, CPM or Orders). A frequency of zero is central in the plot. Negative values extend to the left and positive to the right. The first four orders of running speed are marked in both the positive and negative directions with light red vertical lines. A single cursor is displayed on the highest amplitude in the positive direction. Scaling is set to automatic.

Option Menu

The Option Menu is displayed when the user right-clicks on the Full Spectrum Phase plot. All relevant options supported by the Phase plot are also supported for the Full Spectrum Phase.

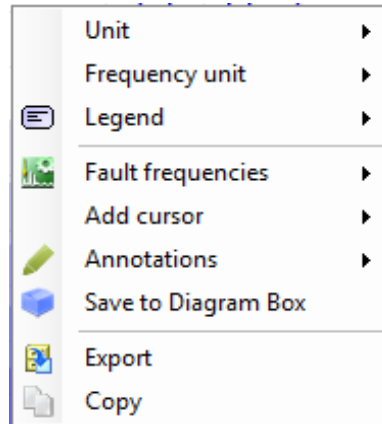

Figure 5 - 11.
Example of Full Spectrum Phase Option Menu.

History



Use this icon to generate a history display of a selected measurement point. History display is used to visualize the variation in machine condition over time in order to identify impending machine faults. History display supports amplitude spectrum, phase spectrum and time waveform or any combination of those. By mouse right-click, it is easy to change the type of data or mode parameter to be displayed. If the single cursor is moved to one of the graphs by the user, all other graphs with the same data type will also be updated to that position making it easier to follow specific frequencies over time. The type of data selected to be displayed with the mode parameter is remembered for this measurement point the next time the history display is opened.

Zooming in one graph also triggers a zoom in the other graphs with the same data type.

Double clicking on one graph opens the plot in full size screen mode.

Figure 5 - 12 below, is an example of a history display.

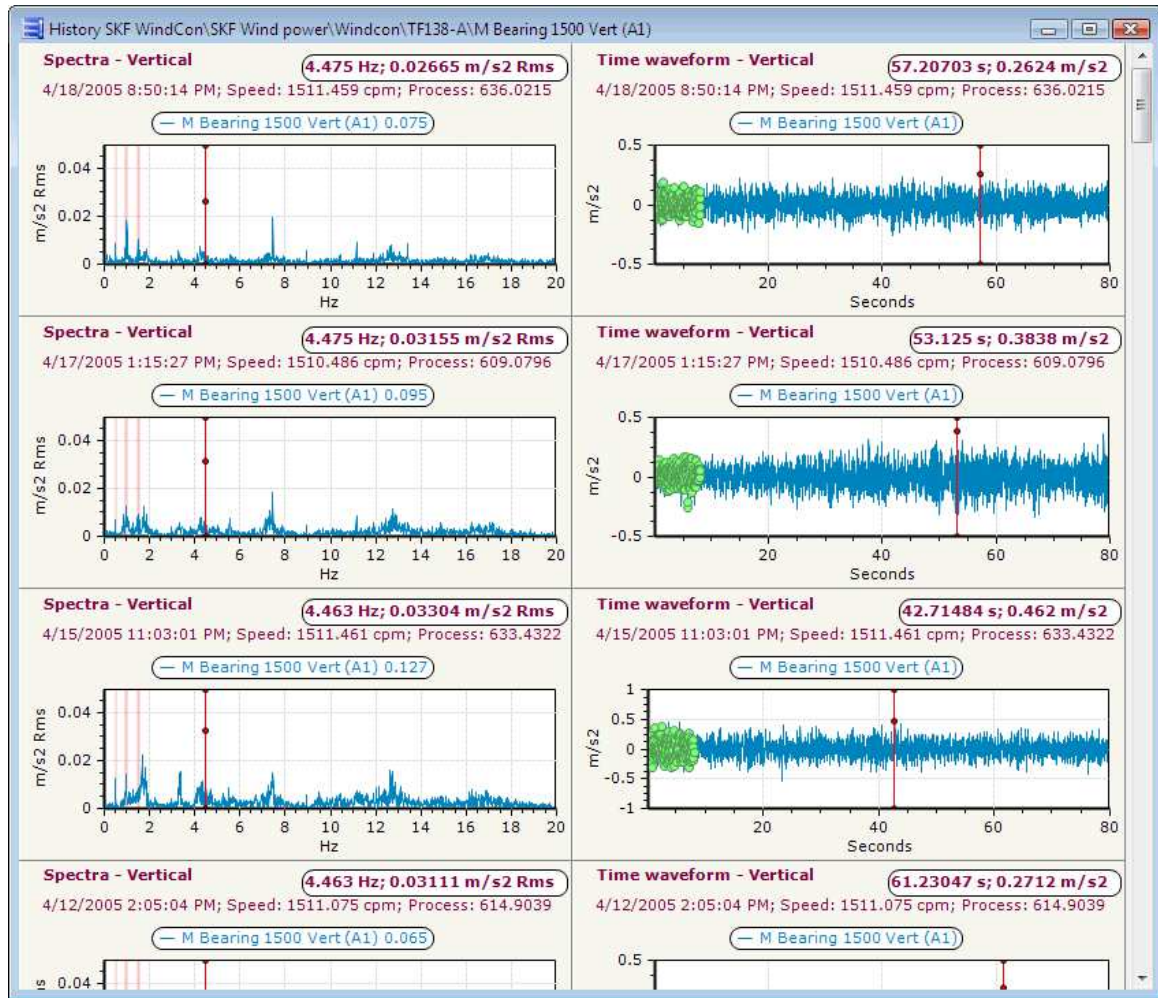

Figure 5 - 12.
Example of History display.

Full Spectrum History

The Full Spectrum History provides a history of Full Spectrum plots. A Full Spectrum plot is used to display a graph of spectrum data collected from two, orthogonally mounted sensors in a dual channel point.

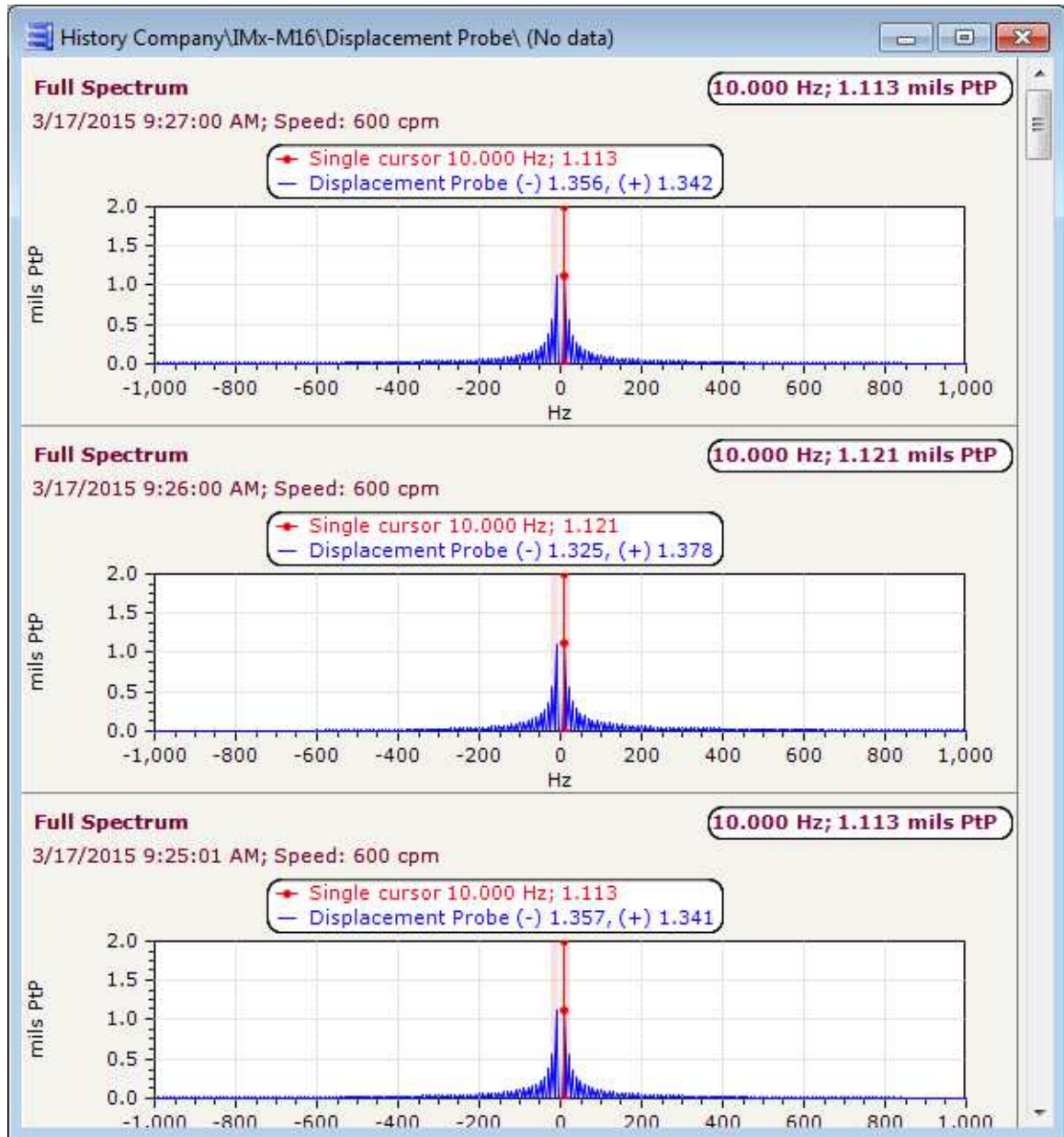

Figure 5 - 13.
Example of Full Spectrum History Plot.

Displaying the Full Spectrum History Plot

The **Full Spectrum** is not the default diagram for the **History plot**. By default, the Spectrum plot is the default, which is displayed by first selecting a point that collects time-waveform data (either Dynamic or Harmonic), then selecting the **History** menu button or right-clicking the point and selecting **Diagram/History**.

The history plot will then display a history of Spectrum measurement data for the point.

The user may launch the **Full Spectrum History** from the **Spectrum History** by right-clicking the plot and selecting **Mode/Full Spectrum** if the following criteria are met:

- The point has 2 channels
- Time waveform data has been collected.

If these criteria are not met, the normal Spectrum History plot is displayed.

Initial Plot description

Each Full Spectrum displayed by the History plot is a fixed-size version of the normal Full Spectrum with the most recent measurement at the top. A scroll bar is added to view older Full Spectrum measurements.

The horizontal axis represents frequency (in Hz, CPM or Orders). A frequency of zero is central in the plot. Negative values extend to the left and positive to the right. The first four orders of running speed are marked in both the positive and negative directions with light red vertical lines. A single cursor is displayed on the highest amplitude in the positive direction. Scaling is set to automatic.

Option Menu

The Option Menu is displayed when the user right-clicks on the Full Spectrum History plot. All relevant options supported by the Spectrum plot are also supported for the Full Spectrum History.

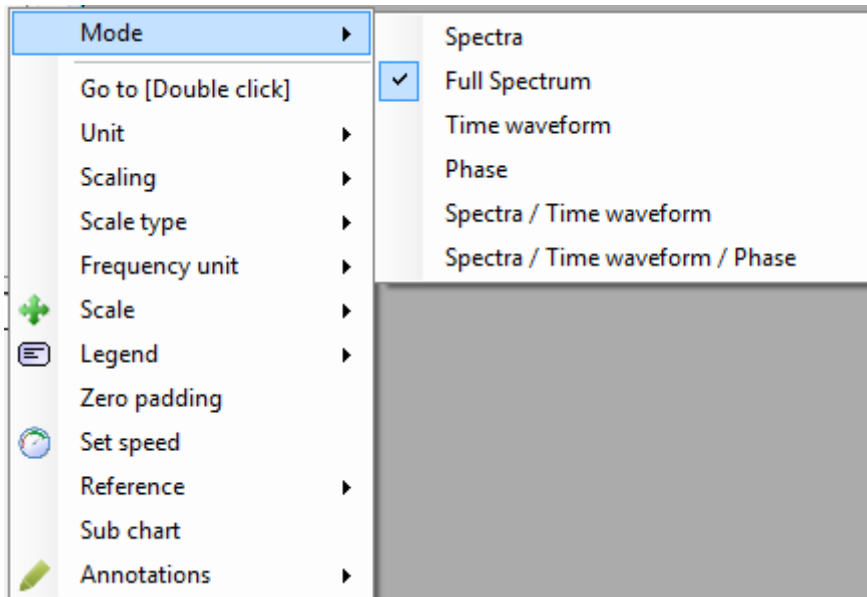

Figure 5 - 14.
Example of Full Spectrum History Option Menu.

3D Plot



Use this icon to generate a 3D/waterfall display of a selected measurement point or multiple selected points when available. As in time waveform and spectrum displays, the amplitude axis can be recalculated between acceleration, velocity and displacement. 3D plots also have a z- or depth-axis, where the depth is date/time, speed, power or any other DC parameter.

They are commonly used during run-up and coast-down, but can also be used for other types of data. A 3D plot can be freely rotated and elevated by the user to improve visibility and the user can select to display a 3D plot as transparent or filled by the user preferences settings. An option “even spreading” that displays the FFT data evenly spaced on the z-axis, is also available.

Figure 5 – 15 below, is an example of a 3D plot of spectral data, against time/date.

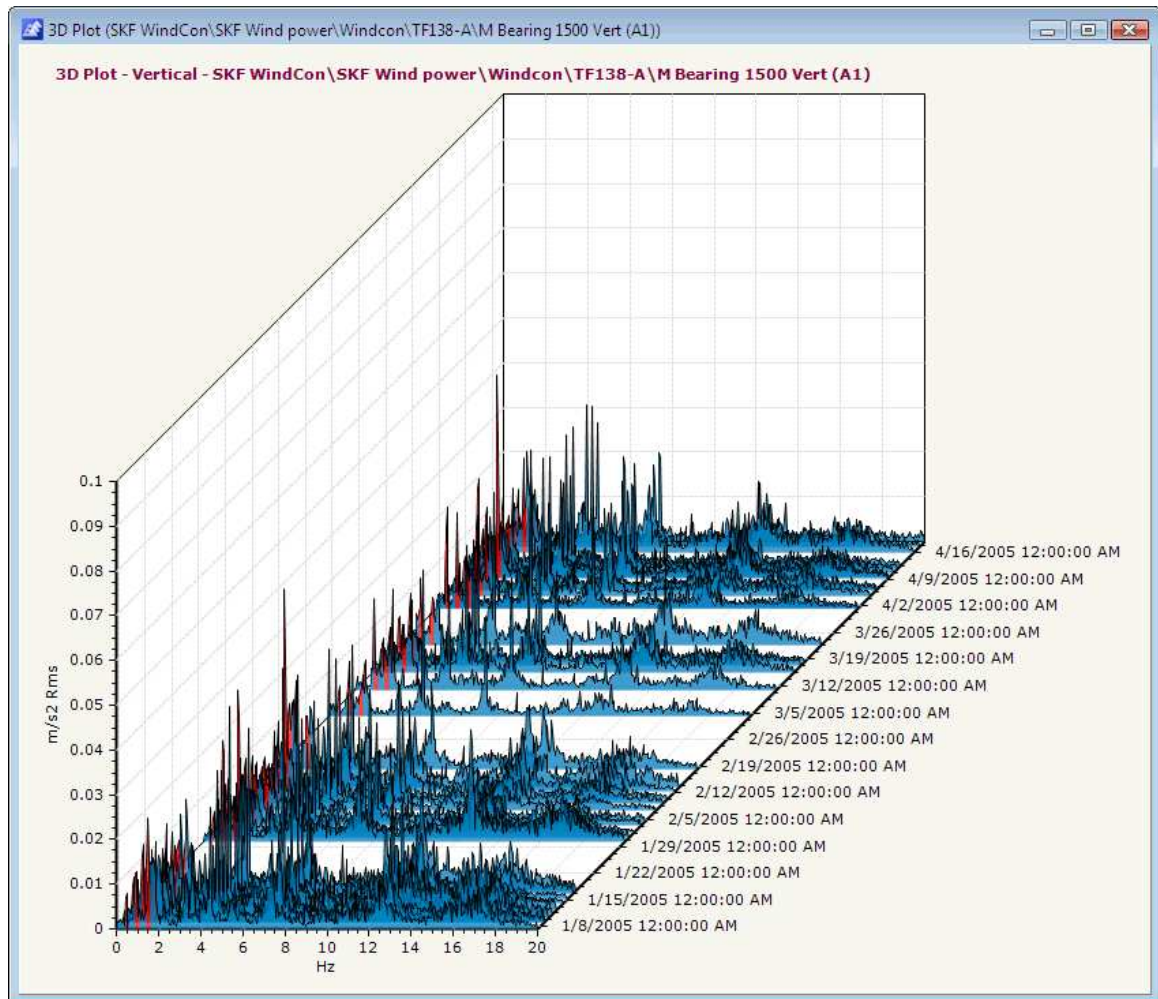

Figure 5 - 15.
Example of a 3D Plot Display.

Full Spectrum 3D Plot

The Full Spectrum 3D Plot provides an enhanced view of the existing Spectrum 3D Plot. The Full Spectrum 3D Plot is used to display a graph of spectrum data collected from two, orthogonally mounted sensors in a dual channel point.

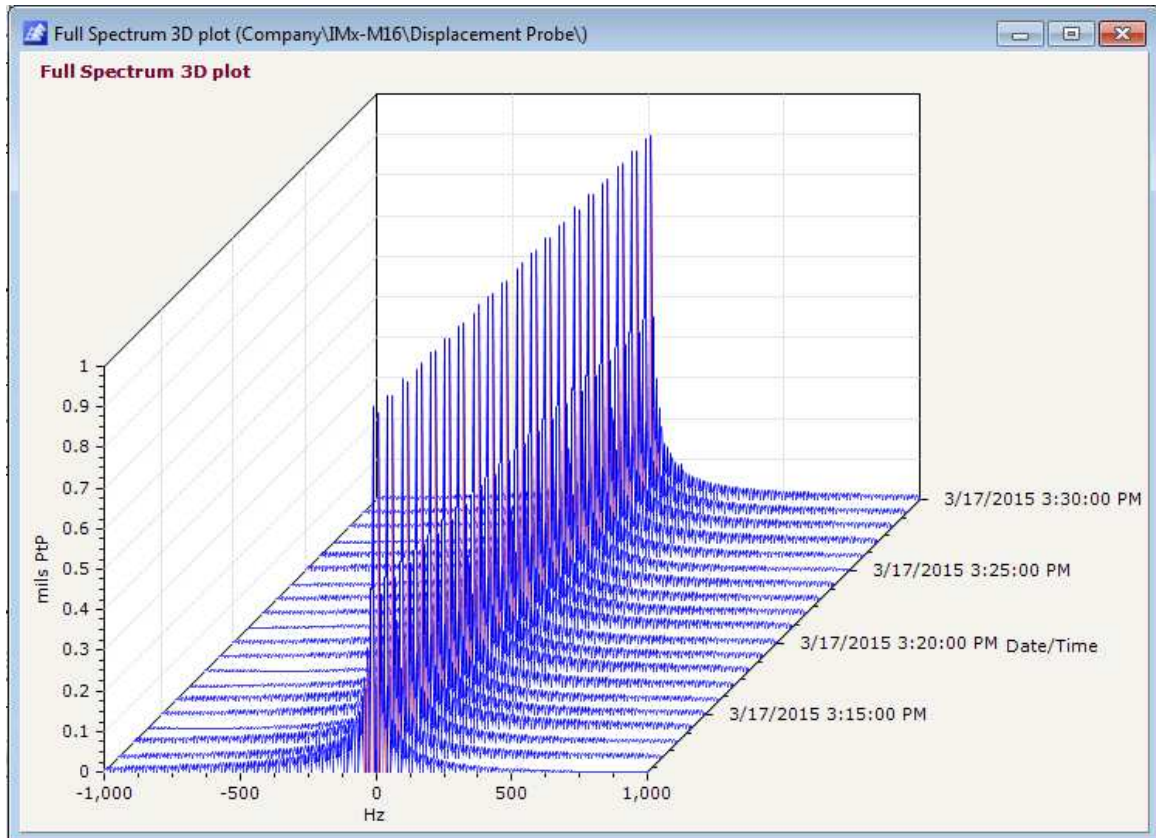

Figure 5 - 16.
Example of a Full Spectrum 3D Plot.

Displaying the Full Spectrum 3D plot

The **Full Spectrum 3D Plot** is not the default diagram for spectral data. By default, the **Spectrum 3D Plot** is the default, which is displayed by first selecting a point that collects time-waveform data (either Dynamic or Harmonic), then selecting the **3D Plot** menu button or right-clicking the point and selecting **Diagram/3D Plot**.

If the user enters the Edit/User Preferences menu and selects the Full Spectrum = True option, clicking on the Spectra menu button or right-clicking the point and selecting **Diagram/3D Plot** will launch the **Full Spectrum 3D Plot** assuming the following criteria are met:

- The point has 2 channels
- Time waveform data has been collected.

If these criteria are not met, the normal Spectrum 3D Plot is displayed.

The user may also launch the Full Spectrum 3D Plot from the Spectrum 3D Plot by right-clicking the plot and selecting Full Spectrum. Likewise, the user may launch the Spectrum 3D plot from the Full Spectrum 3D.

Initial Plot description

The horizontal axis represents frequency (in Hz, CPM or Orders). A frequency of zero is central in the plot. Negative values extend to the left and positive to the right. The first four orders of running speed are marked in both the positive and negative directions with light red vertical lines. A single cursor is displayed on the highest amplitude in the positive direction. Scaling is set to automatic.

Option Menu

The Option Menu is displayed when the user right-clicks on the Full Spectrum plot. All relevant options supported by the Spectrum 3D plot are also supported for the Full Spectrum version.

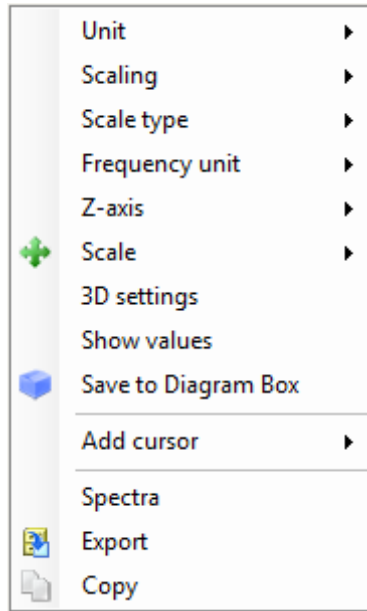

Figure 5 - 17.
Example of Full Spectrum 3D Plot Option Menu.

Topology



Use this icon to generate a topology display of a selected measurement point. Topology shows the frequency versus the time or speed with the amplitude colour coded. This is a useful display to study transient data like run-ups or coast-downs. A topology plot is like a 3D plot, but the user is looking at the data from above. With the colour encoding, it is easier for the eye to identify patterns in the data.

As in other displays, the data can be recalculated on the fly to display data in acceleration, velocity or displacement terms and the y-axis can represent data from a different time/date, speed or process value.

Just like the z-axis of a 3D plot, even spacing of data on the y-axis is also possible.

Figure 5 - 18 below, is an example of a topology display.

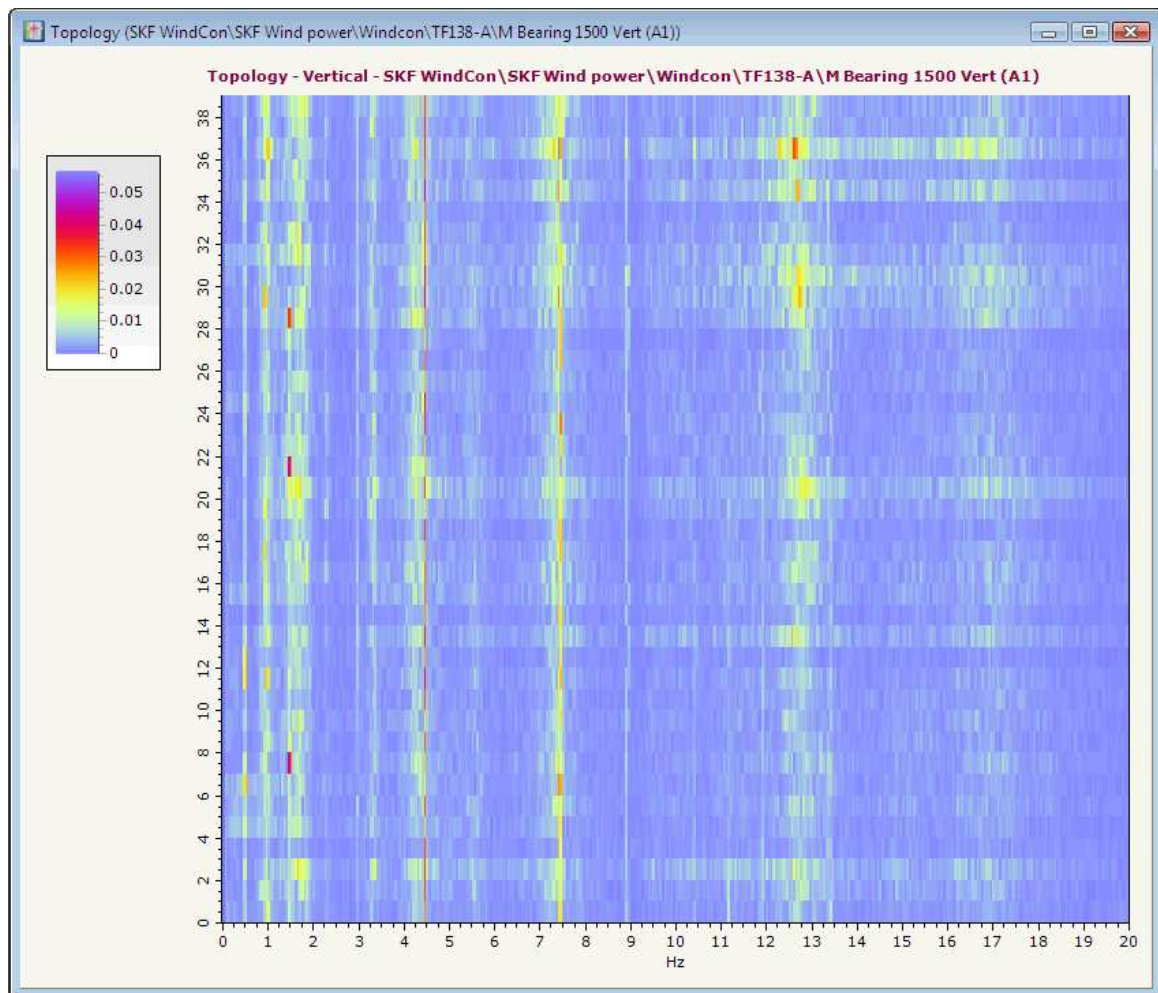

Figure 5 - 18.
Example of a Topology Display.

Full Spectrum Topology Graph

The Full Spectrum Topology graph provides an enhanced view of the existing Spectrum Topology graph. The Full Spectrum Topology graph is used to display a graph of spectrum data collected from two, orthogonally mounted sensors in a dual channel point.

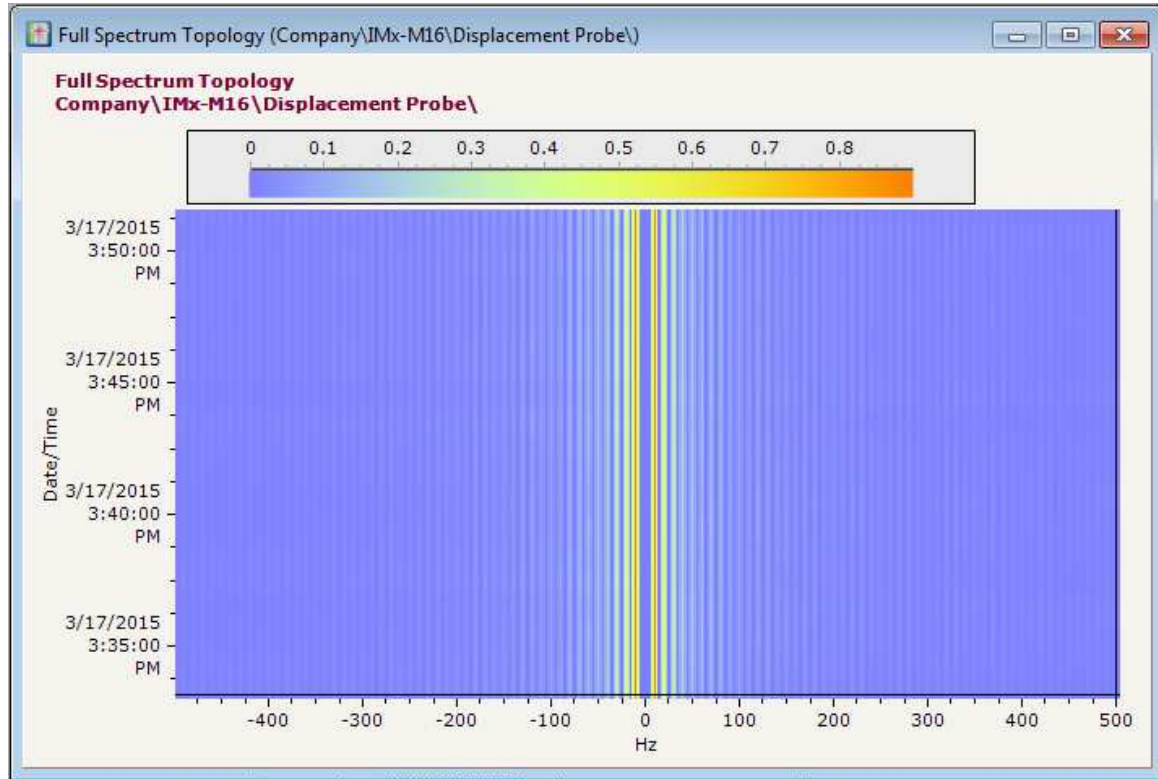

Figure 5 - 19.
Example of a Full Spectrum Topology Graph.

Displaying the plot

The **Full Spectrum Topology graph** is not the default diagram for spectral data. By default, the **Spectrum Topology graph** is the default plot, which is displayed by first selecting a point that collects time-waveform data (either Dynamic or Harmonic), then selecting the **Topology graph** menu button or right-clicking the point and selecting **Diagram/Topology graph**.

If the user enters the Edit/User Preferences menu and selects the Full Spectrum = True option, clicking on the Spectra menu button or right-clicking the point and selecting **Diagram/Topology graph** will launch the **Full Spectrum Topology graph** assuming the following criteria are met:

- The point has 2 channels
- Time waveform data has been collected.

If these criteria are not met, the normal Spectrum Topology graph is displayed.

The user may also launch the Full Spectrum Topology graph from the Spectrum Topology graph by right-clicking the plot and selecting Full Spectrum. Likewise, the user may launch the Spectrum Topology graph from the Full Spectrum version.

Initial Plot description

The horizontal axis represents frequency (in Hz, CPM or Orders). A frequency of zero is central in the plot. Negative values extend to the left and positive to the right. The first four orders of running speed are marked in both the positive and negative directions with light red vertical lines. A single cursor is displayed on the highest amplitude in the positive direction. Scaling is set to automatic.

Option Menu

The Option Menu is displayed when the user right-clicks on the Full Spectrum plot. All relevant options supported by the Spectrum Topology graph are also supported for the Full Spectrum version.

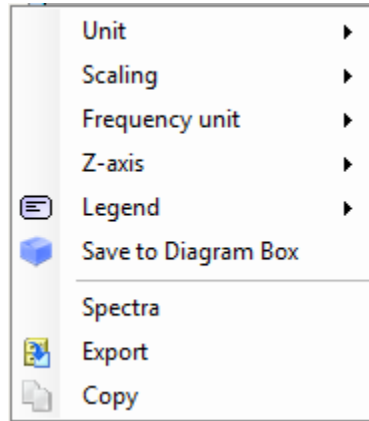

Figure 5 - 20.
Example of Full Spectrum Topology Graph Option Menu.

Orbit



Use this icon to generate an orbit display of a selected measurement point or multiple selected points when available. An orbit display is one of the best ways to analyse shaft movement. By combining phase and amplitude data from two sensors and plotting them together, it is possible to determine unbalance and alignment problems.

@plitude Observer uses two measurement points to generate an orbit display. For the best result, the measurement points must be measured simultaneously or measured with a trigger pulse.

It is also important that the sensors are mounted at the same location but orientated close to 90 degrees apart. For two or three axis sensors this is automatically the case but when using separate sensors, appropriate mounting locations must be selected.

If trigger pulse information is available, the pulses are represented by small round circles in the display. Figure 5 - 21 below, is an example of an orbit graphic display with trigger pulses shown.

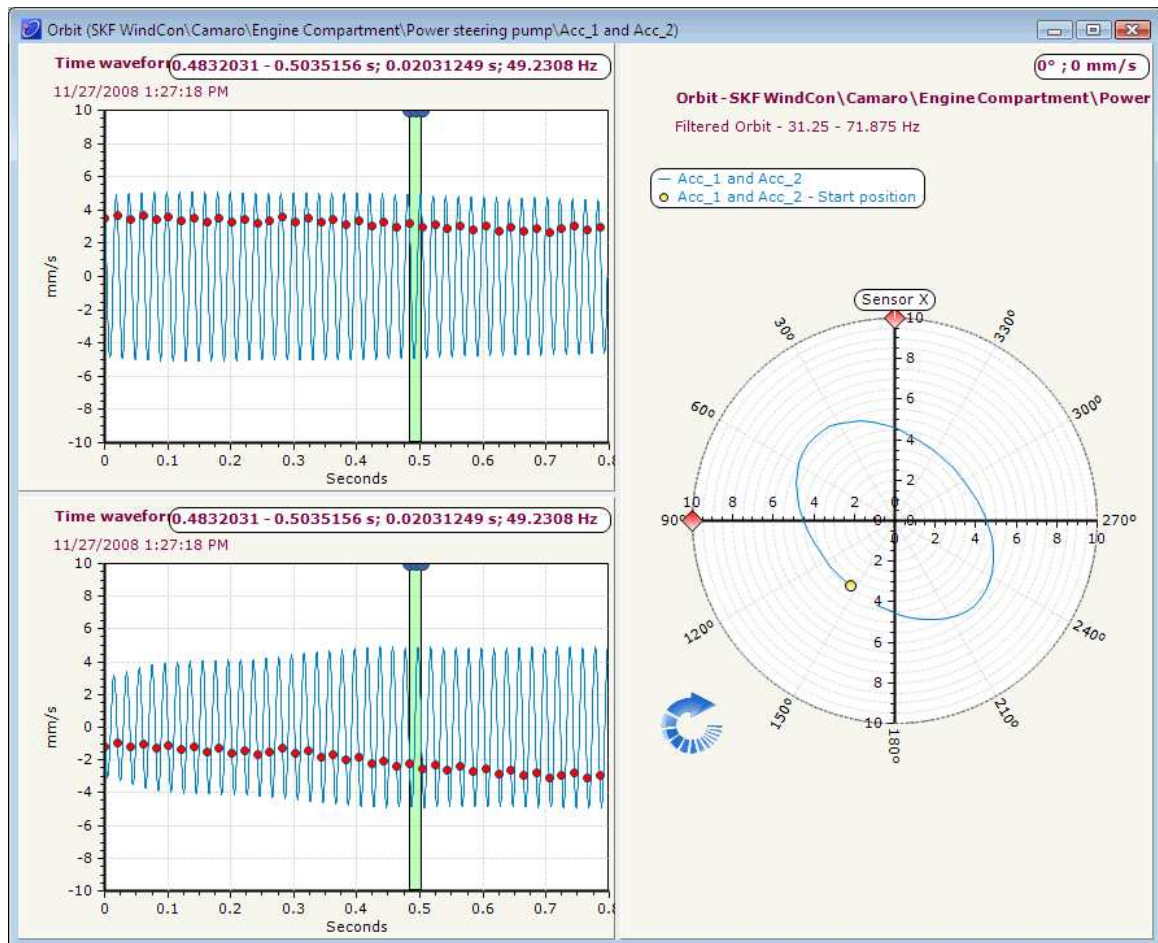

Figure 5 - 21.
Example of an Orbit Display.

Profile



Use this icon to generate a profile display of a selected measurement point. Profile is a powerful tool which uses triggered acceleration time signal data to represent the roundness of any circular object. Examples of components that can be analysed using this feature are paper machine rollers and train wheels. The profile display can use displacement, acceleration, velocity or envelope as the measuring unit but displays an acceleration time signal representing the smoothness of the round object. To get an accurate profile, it is necessary to make sure that the time signal contains at least 20 samples per revolution, over at least the minimum number of revolutions. Note though, for a good representation, it is recommended that there are at least 180 samples per revolution.

Figure 5 - 22 below, is an example of a profile graphic display with the data from two shafts, overlaid.

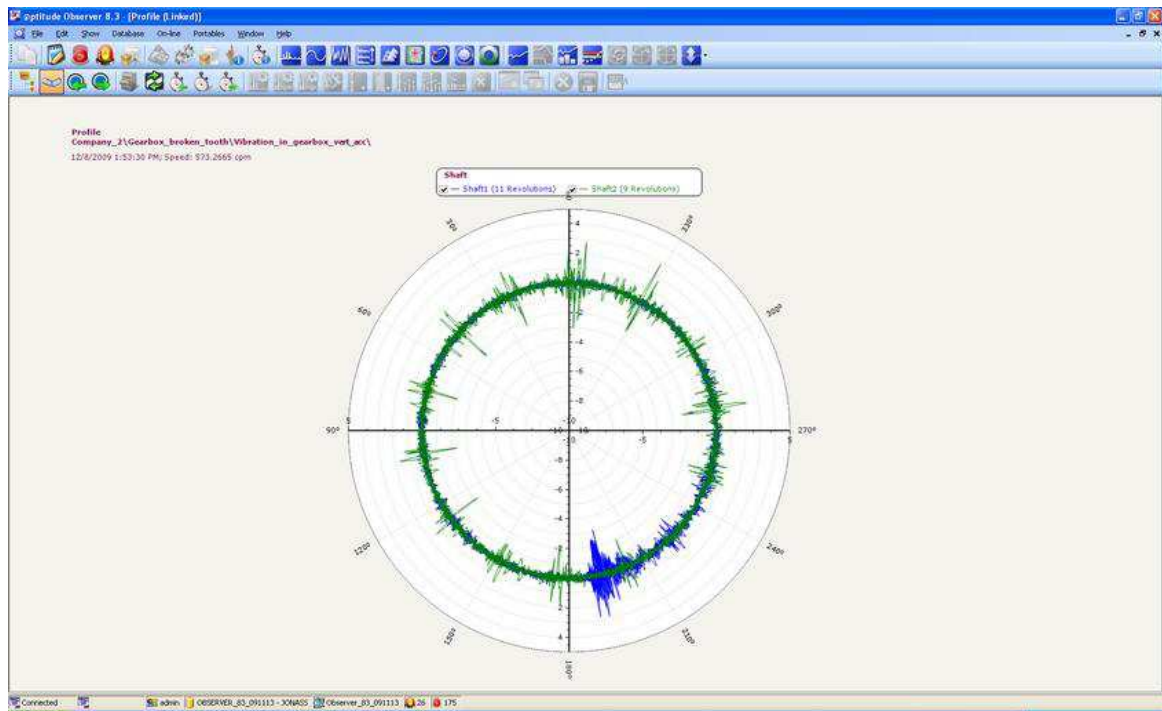

Figure 5 - 22.
Example of a Profile Display.

Gear Inspector



Use this icon to generate a gear inspector display of a selected measurement point. Gear inspector is both a graphical display and an intuitive data gathering technique that helps detecting and visualizing the impact energy as a function of shaft/gear revolutions. It harnesses the best possible method of detecting this energy by using all channels in simultaneous data gathering mode. One graph for each shaft is plotted in a single view using the treated simultaneously gathered data. Impact energy is visualized by using a colour palette. Plots are auto-scaled and speed deviations are compensated automatically. Sensing channels can be freely configured using the measurement groups and sub machine setup.

This is useful in analysing gearbox problems in constantly varying speed and load applications as well as steady state applications. It is effective in detecting broken or damaged gear teeth, loose or worn gears, shaft problems, oval gears and other cyclic related problems.

Figure 5 - 23 below, is an example of a gear inspector display.

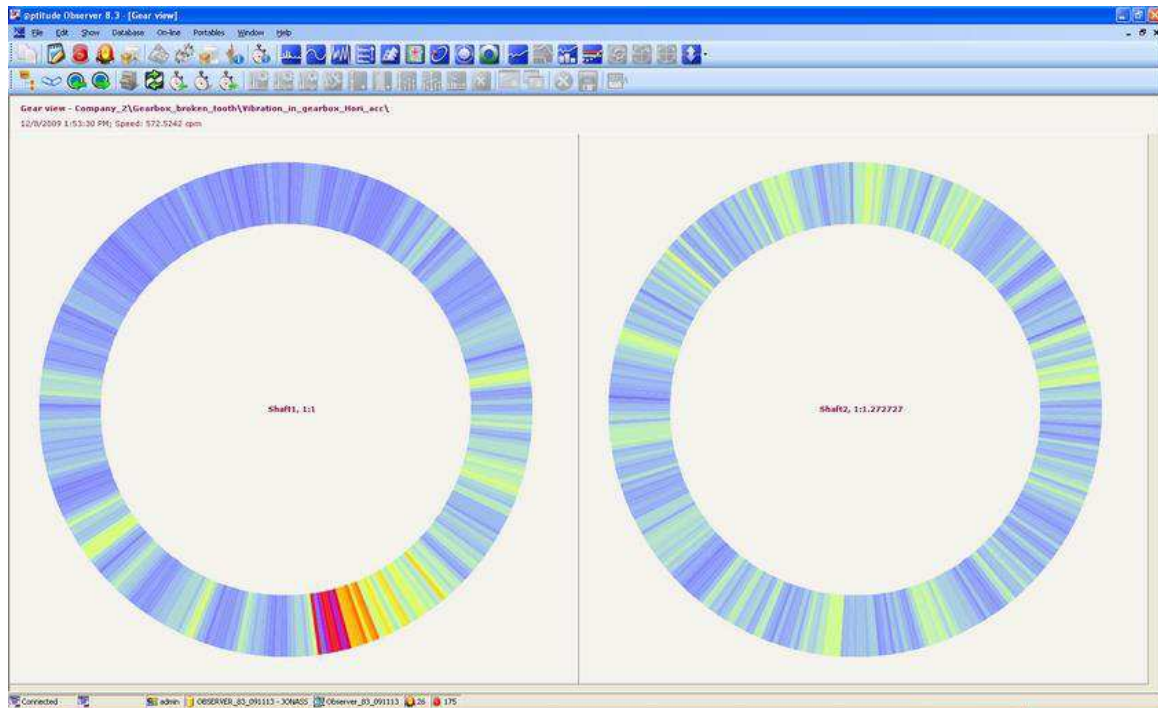

Figure 5 - 23.
Example of a Gear Inspector Display.

Trend



Use this icon to generate a trend display of a selected measurement point. Trend shows any type of data such as vibration amplitude/phase or process data as a function of time, speed or other process data. It is also possible to show the data evenly spaced by simply selecting x-axis and values which will cause the graph to display the data in the order that the values were taken. This x-axis setting is preferred when viewing live data. Not only can the graph display data as a function of speed and process data, but it can also overlay bias, process, phase, speed and digital data on extra axes.

In addition, trend displays spectra and notes flags in the plot shown as diamonds and circles, respectively. By clicking these flags with the mouse, the corresponding spectra data and note information are displayed to the user making it easier to follow machine specific maintenance history.

In the legend section of the graph screen, there is an option to have system log displayed. System log displays all the configuration changes made by the user through the history. System log is marked with red squares.

When trending measurements from a Multiple Gating Point, the legend shows the name of the operating class active at the time of the measurement.

When trending measurements linked to an event capture group with stored events, clicking the event capture indicator will open a window for further analysis. The window displays the event captures for the point. The list view selection shows the event that was selected on the trend plot and a thumbnail display showing the same.

During run-up/down a reference measurement can be shown in the same display with actual values or a value calculated as a percentage of the alert level.

Below, Figure 5 – 24, is an example of a trend display with notes and spectra flags enabled.

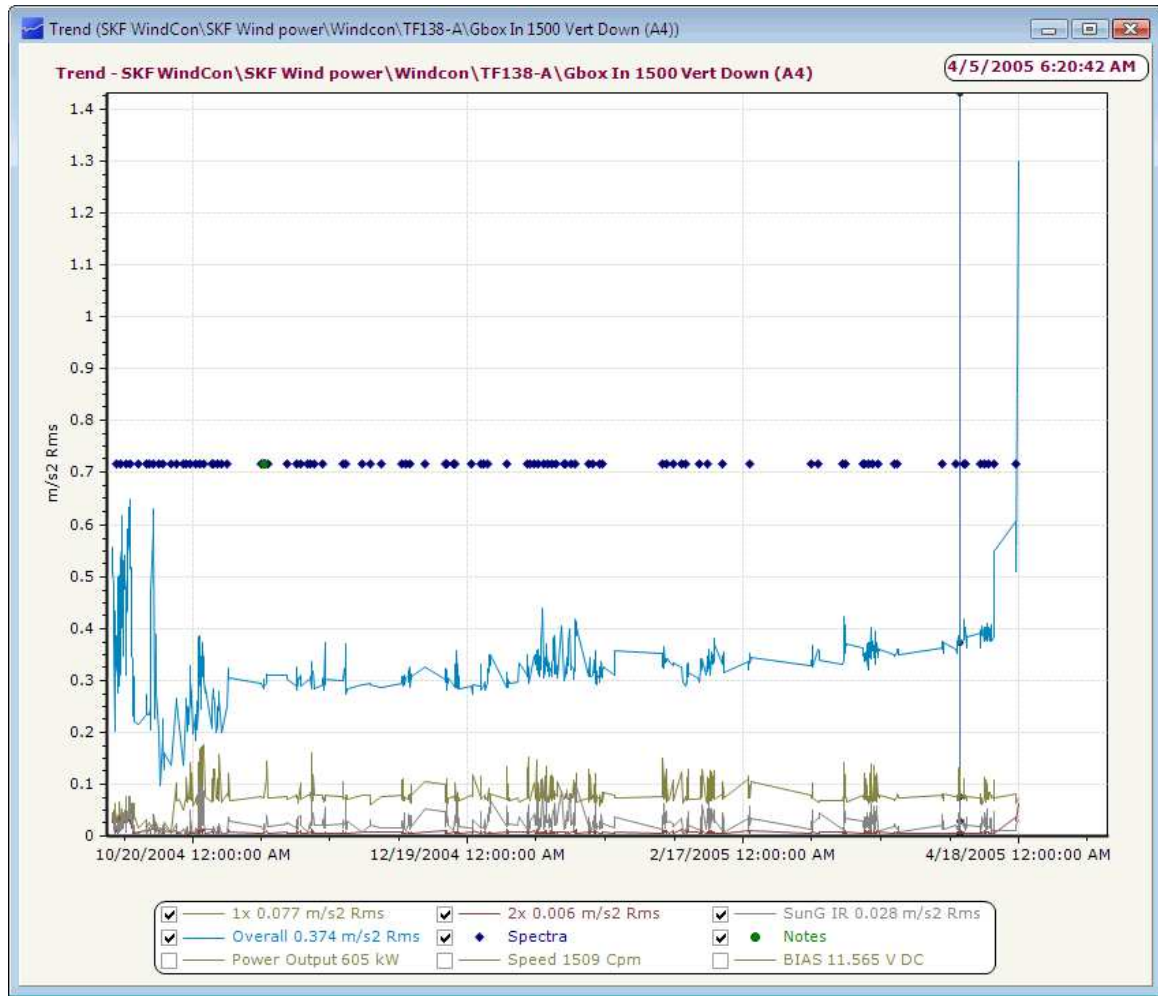

Figure 5 - 24.
 Example of a Trend Display.

Bode



Use this icon to generate a bode plot of a selected measurement point. Bode plots usually show vibration amplitude/phase as a function of speed. A Bode plot is identical to that of trend display with the x-axis set to speed and with phase always visible. See also [Trend](#) diagram.

Trend List



Use this icon to generate a trend list display of a measurement point or measurement points which were selected in the hierarchy. Trend list shows the trend data values in a tabular format. The data can be sorted by clicking on any column header. The data can also be printed as a report.

When listing measurements from a Multiple Gating Point, the **Overall** column shows the name of the operating class active at the time of the measurement.

Meas. point	Date/Time	Speed	E.U.	Overall	1 x N Amp	1 x N Phase	2 x N Amp	2 x
Main Brg Radial ACC (1kHz)	2010-09-16 00:28:53.00	163	g P	0				
Main Brg Radial ACC (1kHz)	2010-09-16 00:29:53.00	163	g P	0				
Main Brg Radial ACC (1kHz)	2010-09-16 00:30:49.00	163	g P	0				
Main Brg Radial ACC (1kHz)	2010-09-16 00:31:41.00	326	g P	0				
Main Brg Radial ACC (1kHz)	2010-09-16 00:32:40.00	326	g P	0,01				
Main Brg Radial ACC (1kHz)	2010-09-16 00:33:41.00	326	g P	0,01				
Main Brg Radial ACC (1kHz)	2010-09-16 00:34:33.00	326	g P	0				
Main Brg Radial ACC (1kHz)	2010-09-16 00:35:29.00	326	g P	0,01				
Main Brg Radial ACC (1kHz)	2010-09-16 00:36:24.00	326	g P	0,01				
Main Brg Radial ACC (1kHz)	2010-09-16 00:37:20.00	326	g P	0,01				
Main Brg Radial ACC (1kHz)	2010-09-16 00:38:12.00	326	g P	0				
Main Brg Radial ACC (1kHz)	2010-09-16 00:39:07.00	326	g P	0				
Main Brg Radial ACC (1kHz)	2010-09-16 00:40:05.00	326	g P	0				
Main Brg Radial ACC (1kHz)	2010-09-16 00:41:55.00	326	g P	0				
Main Brg Radial ACC (1kHz)	2010-09-16 16:12:36.00	170	g P	0				
Main Brg Radial ACC (1kHz)	2010-09-16 16:13:31.00	208	g P	0				
Main Brg Radial ACC (1kHz)	2010-09-16 16:14:24.00	208	g P	0				
Main Brg Radial ACC (1kHz)	2010-09-16 16:15:26.00	208	g P	0				
Main Brg Radial ACC (1kHz)	2010-09-16 16:16:23.00	391	g P	0,01				
Main Brg Radial ACC (1kHz)	2010-09-16 16:17:16.00	400	g P	0,01				
Main Brg Radial ACC (1kHz)	2010-09-16 16:18:14.00	400	g P	0,01				
Main Brg Radial ACC (1kHz)	2010-09-16 16:19:12.00	557	g P	0,01				
Main Brg Radial ACC (1kHz)	2010-09-16 16:22:27.00	600	g P	0,01				
Main Brg Radial ACC (1kHz)	2010-09-16 16:23:24.00	600	g P	0,01				
Main Brg Radial ACC (1kHz)	2010-09-16 16:24:10.00	600	g P	0,01				

Figure 5 - 25.
Example of Trend List Display.

Multi trend



Use this icon to generate a multi trend display of a selected measurement point or any other node type in the hierarchy view. Multi trend offers extended functionality to the normal trend plot as it is possible to overlay data from different measurement points or sources making it easier to compare data and distinguish if machines behave differently from each other. This display consists of two parts; one trend display and the other a bar display. The trend display shows historical data in measurement units, in percent of warning level or simply without any unit at all. The bar graph shows the current cursor value in the trend graph where it is easier to compare values against each other for the data selected. Clicking the cursor on any bar in the lower view causes the associated trend in the upper view to become selected (no transparency and heavier line). Any previously selected trend will then become deselected (50% transparency and single point line width).

The legend here differs from the legend in other graphs because it is grouped by different types of measurement units available in all the measurements that are displayed and un-checking any of the units will hide all the measurement points that use this specific measurement unit.

When multi-trending a group of measurements that includes one or more measurements from a Multiple Gating Point, the legend and the bar graph labels show the name of the operating class active for each applicable Multiple Gating Point at the time of the measurement.

The multi trend can have one active measurement point at a time. The trend graph line for the active measurement point is thicker and the text for the Y-scale that the active measurement point uses will be made bold. To switch active measurement point, use the TAB and the SHIFT+TAB keys. Once a measurement point is selected, it can be navigated with the arrow keys just like in the normal trend plot.

The multi trend plot can correlate measurement data between the measurement points in the graph by setting the x-axis scale to a specific measurement point and setting a correlation tolerance in time units.

Figure 5 - 26 below, is an example of a multi trend display.

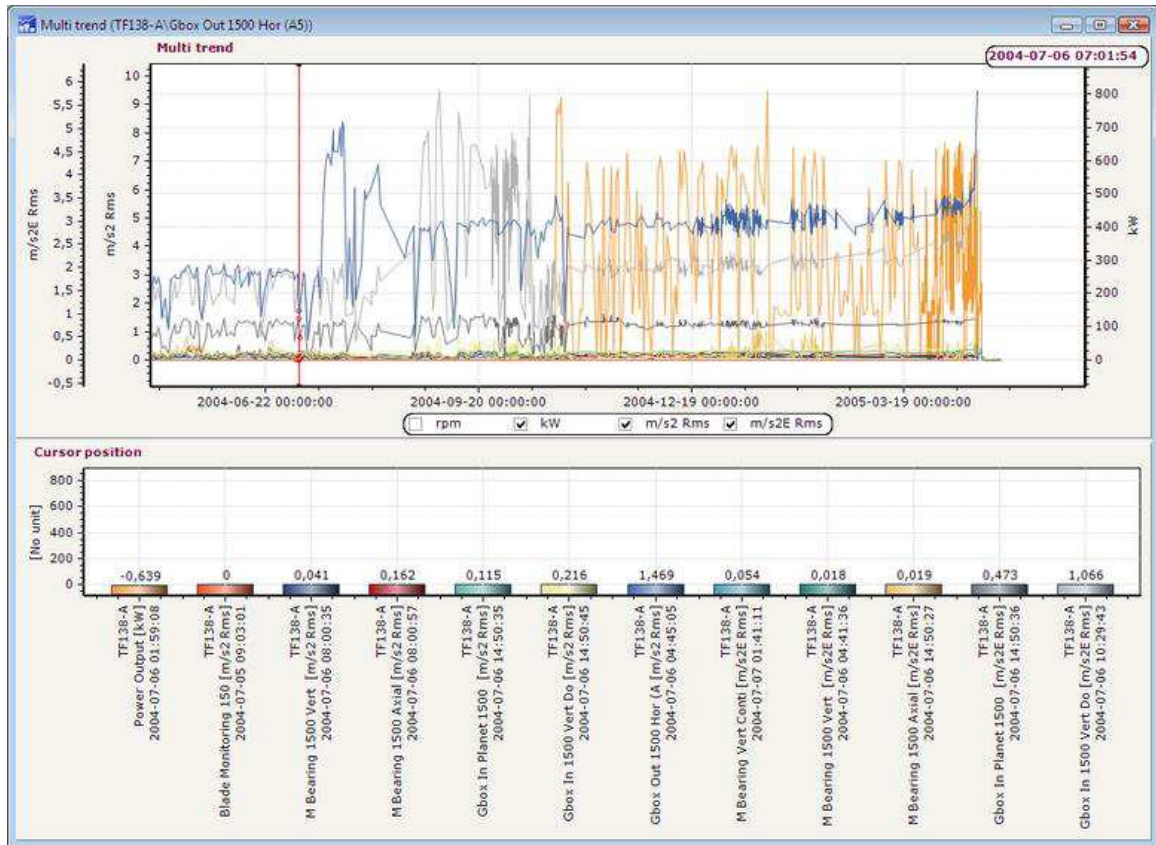

Figure 5 - 26.
Example of Multi Trend Display.

When viewing a multi trend plot, another component can be chosen to be the active measurement instead of the Overall value. Dynamic points can have up to four extra measurement components.

- If a point doesn't have additional components, the Overall value is used.

To select another component:

- Right-click on the plot to open the context menu.

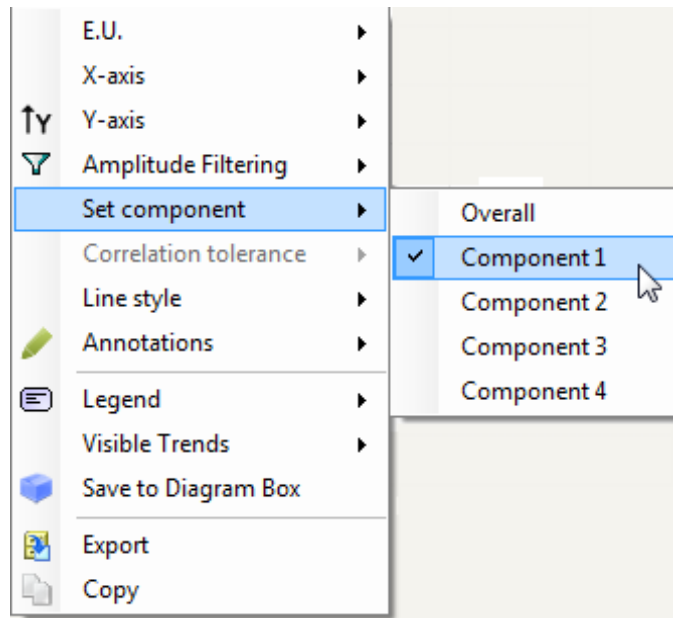

Figure 5 - 27.
Context Menu with Set Component Options.

- Click **Set component** and then select the desired component from the available measurement components shown in the graph. The component selected is indicated with a check mark.

The selected component is added to the plot sub-header.

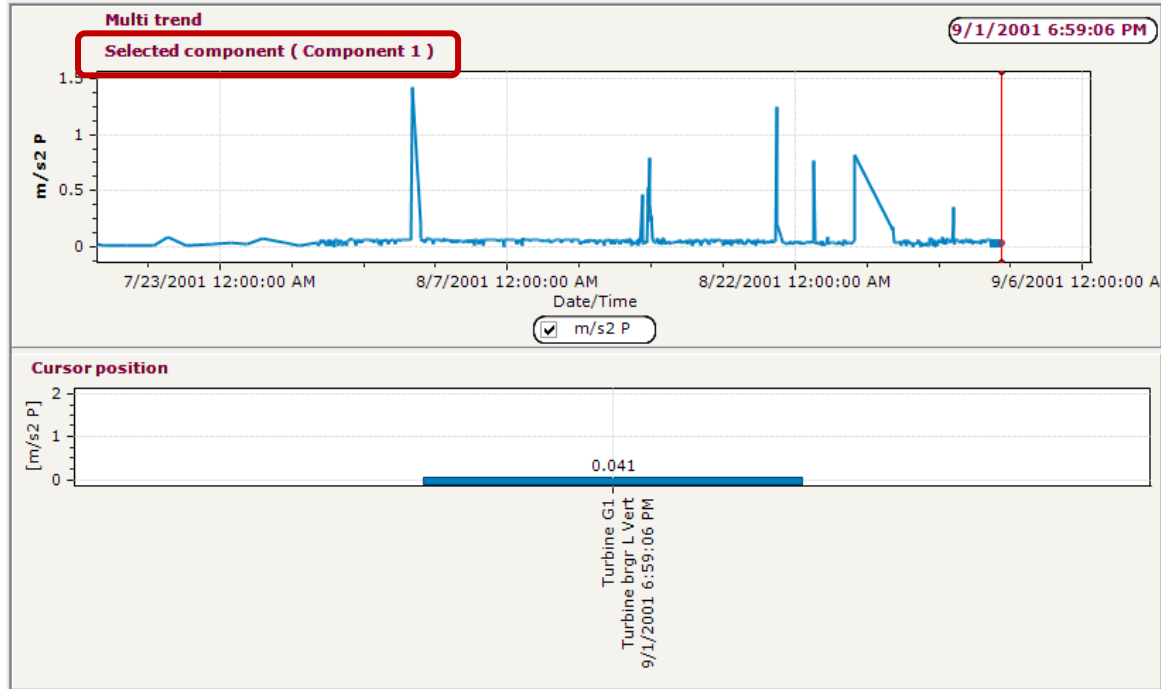

Figure 5 - 28.
Selected Component in Sub-header.

Trends can be hidden from the upper plot and the bar graphs display will remain visible. There are two methods to hide specific trends.

The first method is by using the legend. As described above, the legend here is grouped by the different types of measurement units available in all the measurements that are displayed. Unchecking a measurement unit will hide all the measurement points in the upper plot that use this specific measurement unit.

The other method is by using the **Visible Trends** menu item. Right-click the multi trend plot to open the context menu. Select **Visible Trends**. The options offered in the **Visible Trends** submenu are filtered by the checkboxes selected in the legend. For example, if **Cpm** is unchecked in the legend, then Cpm measurements are removed from the **Visible Trends** options.

In the figure below, all three trends that can be shown for the selected point types are displayed. The corresponding three bar graphs display below.

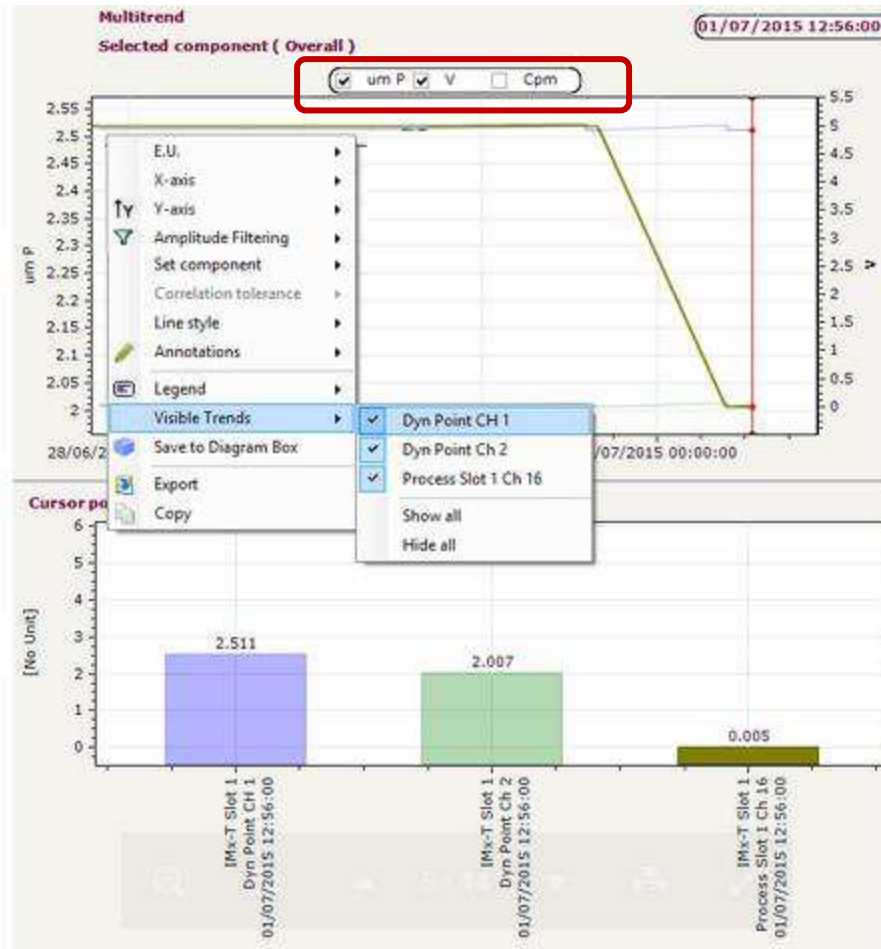

Figure 5 - 29.
Example of Multi Trend Display, Visible Trends Options.

- Right-click the plot and select **Visible Trends** from the menu. Each submenu item represents an available point based on the current units filter setting. All submenu items are checked by default, making them visible.
- Uncheck a specific visible point to hide it from the trend view. Unchecking an item causes the named trend to be hidden and the associated cursor position bar to be unselectable even though still visible. Assuming the trend just hidden is the selected trend, then the next available (and visible) trend will be selected instead.
 - Although the individual trends are hidden, the (red spot) cursor positions remain unchanged.
 - Check the item again to reverse the process described above.
- Select the submenu item **Show all** to cause all unchecked submenu items to be immediately checked and all hidden trends to become visible.
- Select the submenu item **Hide all** to cause all checked submenu items to be unchecked and all visible trends to become hidden.

The example below shows one of the points (Dyn Point Ch2) as deselected (unchecked). Two trends are now displayed (and rescaled). However, the lower bar graph still shows all three points. The bar associated with the invisible trend is no longer selectable even though it is still visible.

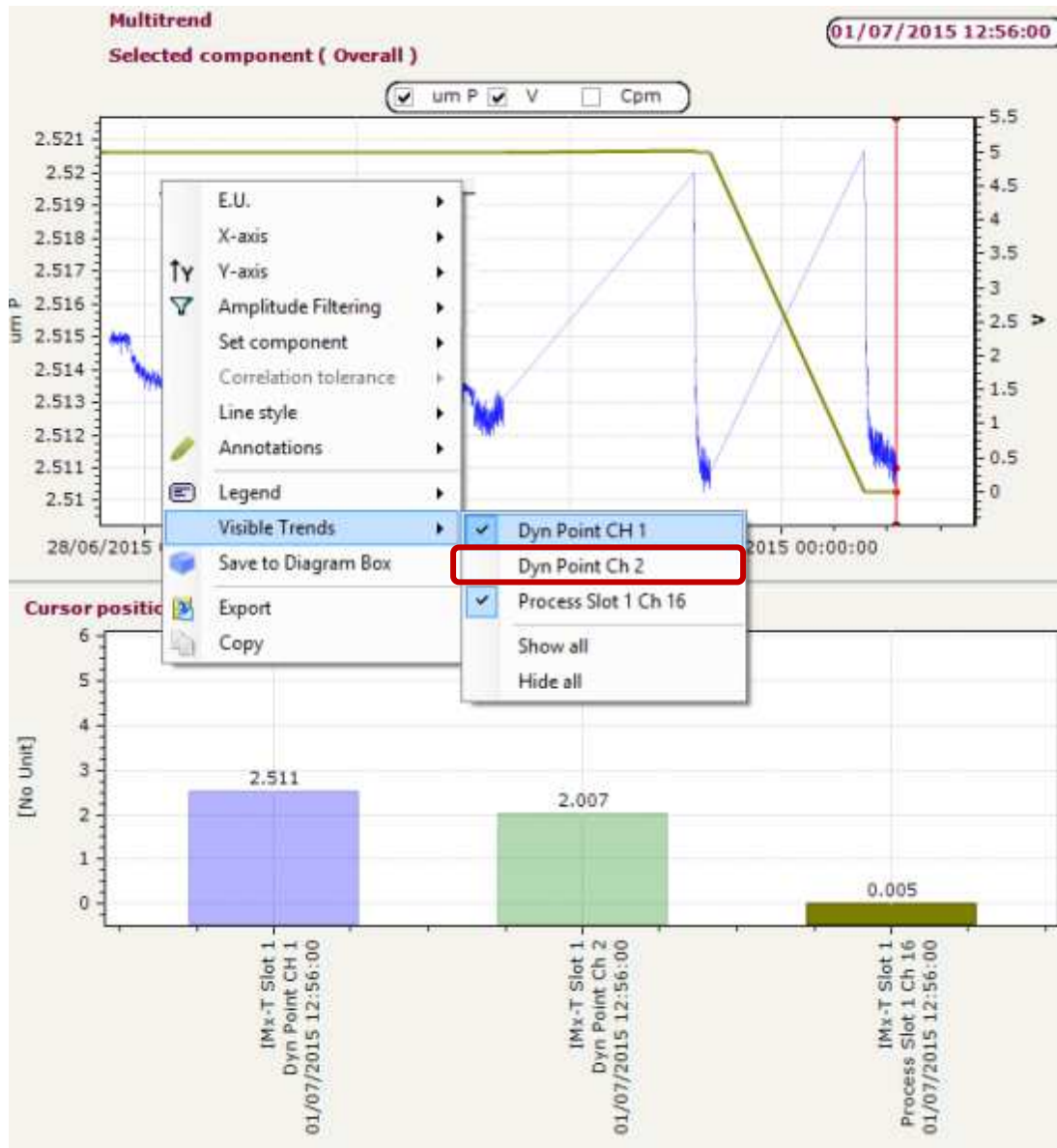

Figure 5 - 30.
Example of Multi Trend Display, Visible Trends Option Unchecked.

Amplitude Filtering on a Multi Trend Plot

The **Amplitude Filtering** option enables values from one measurement point in the multi-trend plot to be filtered, to “fine tune” the display of machine characteristics. When a point is selected, measurements for the selected point that are outside the filter range are excluded from the trend.

Using the amplitude filter:

- With a multi trend plot open, right-click on the plot to open the context menu.
- Select the **Filter** option.
- A sub-menu opens that contains a list of all the points used for the multi trend, as well as an additional option, **Clear amplitude filtering**.

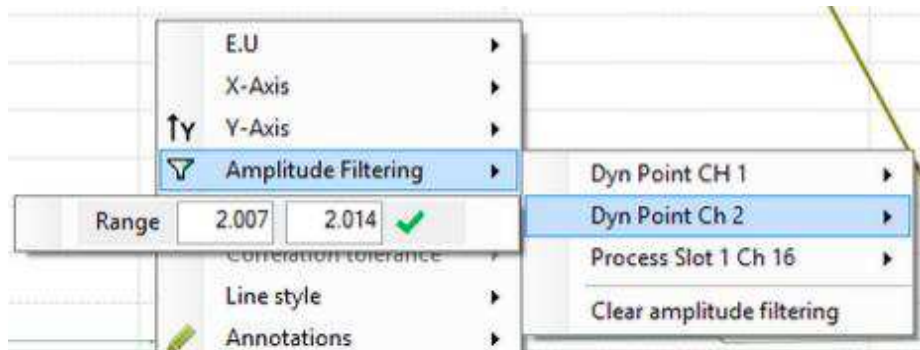

Figure 5 - 31.
Amplitude Filtering Menu and Range Values.

- Select a point. Note that filtering applies only to visible points and only one point at a time.
- Define the filter **Range** by entering both the minimum and maximum values.
 - If the entered range is invalid the green check mark will become a red cross and the values will not be accepted.
- Upon clicking Enter, the plot is redrawn using the new filter range. The range values remain available for further or finer adjustment. The filtered plot is drawn as if the measurements filtered out did not exist, that is, they cannot affect the vertical or horizontal ranges of the plot and do not appear in cursor readouts.

The legend at the top of the plot indicates the filtering condition, for example, “Speed filtered within 2900 to 3200 rpm”.

When this menu is brought up again after filtering has been applied to a point, the point selected is indicated with a small pencil icon on the menu. The submenu for this point presents the current filter values, which may be modified.

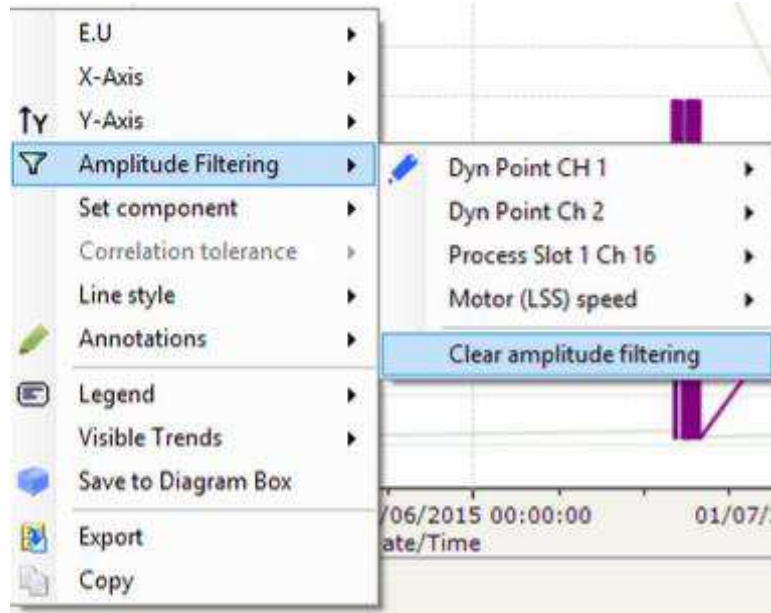

Figure 5 - 32.
Amplitude Filtering Applied to a Point.

If another point is selected and values are entered correctly for its filter range, the filtering selected for the previous point is discarded. The plot is filtered only on the new point's parameters.

Select **Clear amplitude filtering** from the submenu to clear the filtering and redraw the plot.

Diagnosis



Use this icon to generate a diagnosis display of a selected measurement point. This will open the diagnosis display for the measurement point and will display all the attached diagnoses.

The @ptitude Observer Machine Diagnosis is a powerful tool to display and follow the progression of machine faults. Sophisticated diagnosis rules can be applied using defect frequencies of the whole machine with individual alarm level for each measurement point and for each type of fault. Diagnosis diagram shows calculated diagnosis parameters over time related to the alarm level. There are many types of built-in diagnoses available to the user in order to detect specific common machine faults like misalignment, cavitation, mechanical looseness, electrical faults and more.

In the diagnosis display, all the different diagnoses attached to a measurement point are shown in the trend-type of display and calculated based on spectrum data stored in the database. This means that diagnosis can be attached and recalculated even after the measurements have been stored to the database.

Figure 5 - 33 below, is an example of a diagnosis display.

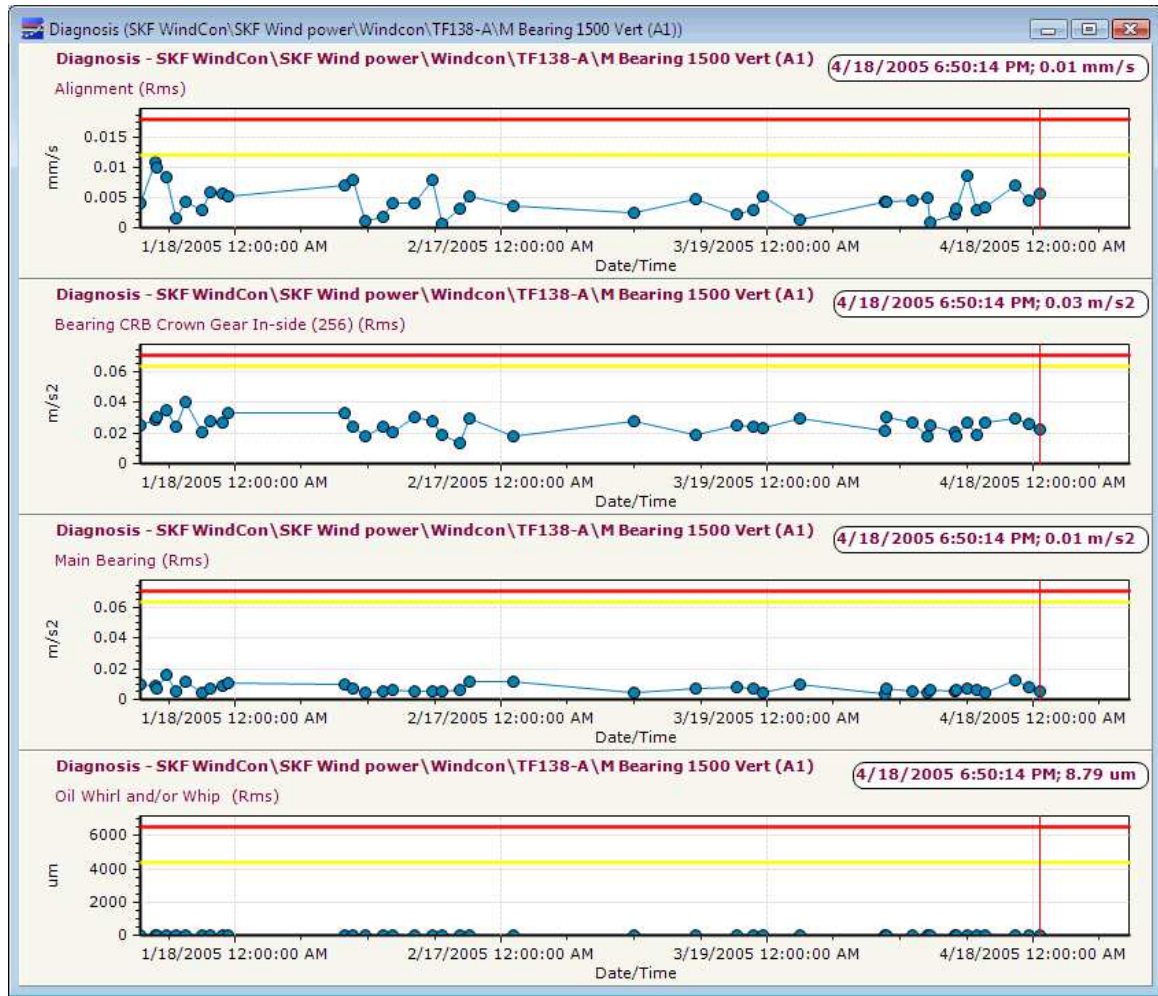

Figure 5 - 33.
Example of Diagnosis Display.

If a point is associated with an MGP as a digital measurement in the Associated measurements area (on the Acquisition tab), the actual running class type is indicated by the background colour in the graph. Note: This occurs only if the x-axis is set to date/time. The background colours displayed are white for No operating class, light blue for Operating class 1 and light grey for Operating class 2.

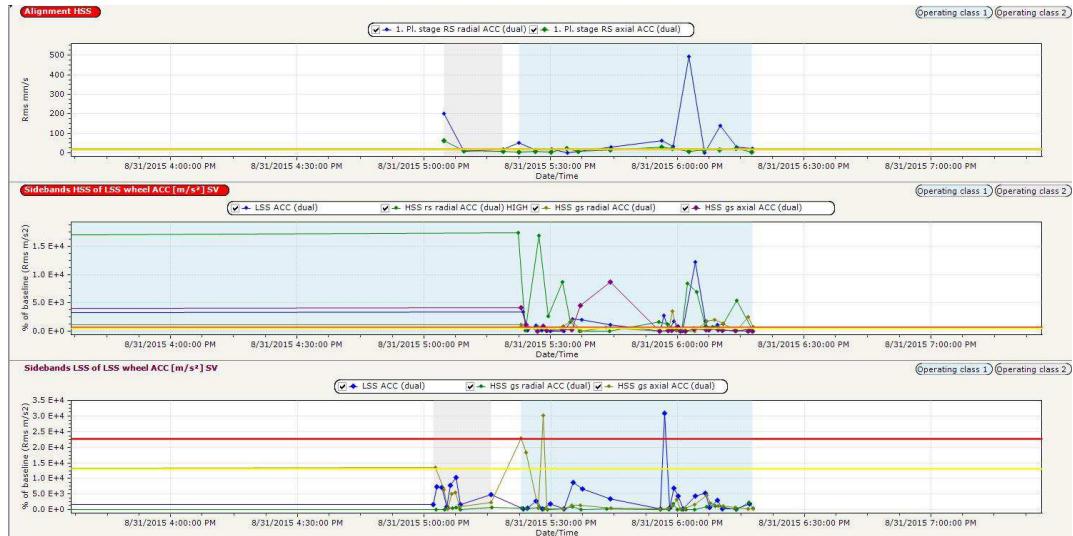

Figure 5 - 34.
Example of Diagnosis Display with Operating Class 1 and Class 2 Data.

The buffer data can be filtered for a specific class by enabling the **Digital** condition and selecting the data class type. Only data for that class will display. When the **Digital** condition is disabled, all data class types are shown in the graph. Refer to [Buffer](#) in System Operation.

In the diagnosis display, baselines can be configured for the different measurement points associated with the diagnoses. If the measurement point has dual class configuration, baselines can be configured for "No operating class", "Operating class 1" and "Operating class 2".

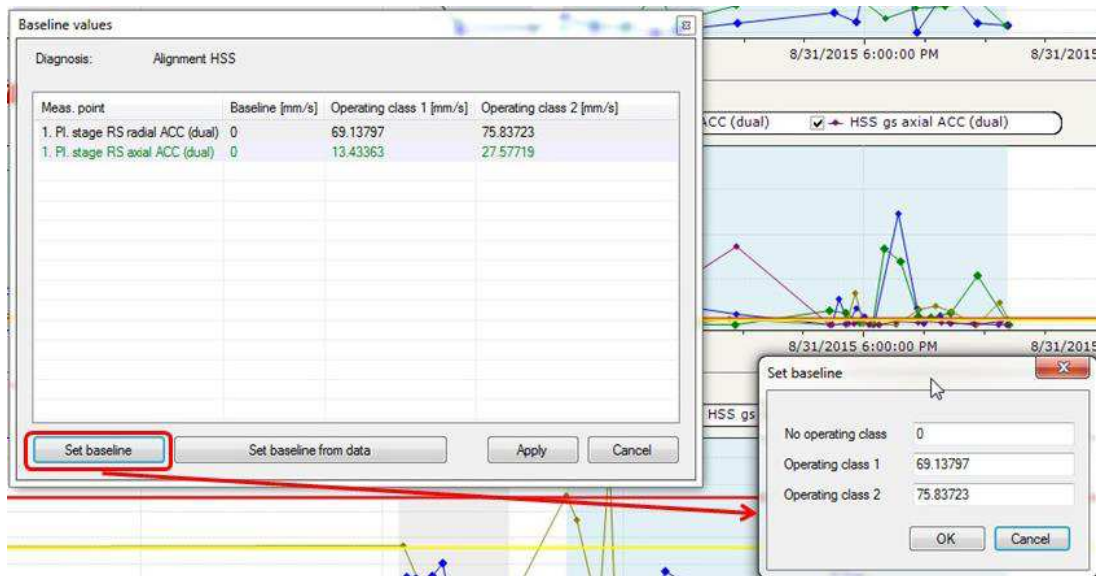

Figure 5 - 35.
Example of Baseline Values for Diagnosis Display.

Protean



Use this icon to open the Protean diagnosis display for the measurement point and display all the attached diagnoses.

The @ptitude Observer Machine Protean diagnosis is a powerful tool to display and follow the progression of machine condition indicators. Protean diagnosis uses parts of the traditional Observer diagnoses and added AI (Artificial Intelligence), machine learning. For the user this means:

- All condition indicators are generated by the AI/machine learning algorithm with no input from the user (formerly called alarms).
- The alarm mechanism is intelligent and can notify the user when the condition of the machine has worsened. When detecting machine incidents with continuing deterioration there will be a, further, second indication if the machine health reaches another much more severe state.
- Machine indicators will also identify (positive) changes in the machine, like a bearing replacement and then adjust the indicators for a new baseline.
- The AI/machine learning for Protean diagnoses has been evaluated and fine-tuned by SKF using data lakes with several years of data from millions of data streams to ensure they are extremely accurate.

The Protean diagnosis diagram shows calculated diagnosis parameters over time relative to the learned alarm level.

There are many types of built-in Protean diagnoses available to the user for detection of specific common machine faults like misalignment, bearing damage and mechanical looseness. These built in Protean diagnoses have been pre-learned using real data, so as to be very accurate. The user need not do any setup to find and identify common machinery problems.

In the diagnosis display, all the different diagnoses attached to a measurement point are shown in the trend-type display and calculated based on spectrum data stored in the database. This means that Protean diagnosis can be attached and recalculated even after the measurements have been stored to the database with the choice of generating alarms.

The figure below is an example of a Protean diagnosis of mechanical looseness.

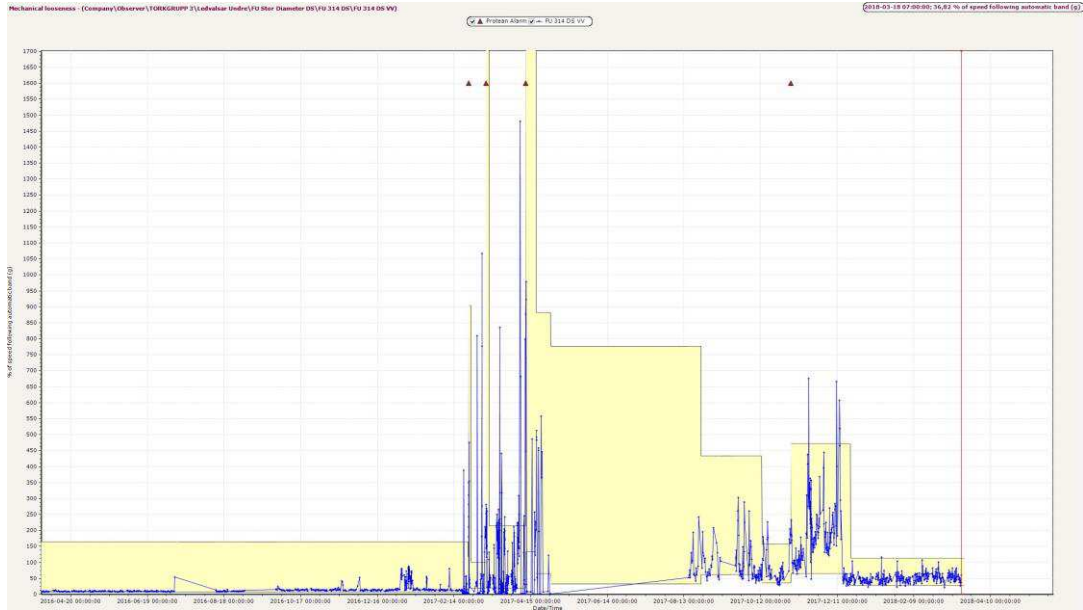

Figure 5 - 36.
Example of Protean Diagnosis with self-learned trigger level.

For more information refer to Appendix C, [Protean Diagnosis](#).

Polar



Use this icon to generate a polar display of a selected measurement point. Polar display shows the vibration signal at 1, 2, 3 and 4 times the shaft speed in the complex domain. The vector is described with amplitude and phase. Polar display is an effective tool for detecting changes in the phase domain and changes in amplitude and/or phase. It is often used to analyse run-ups and coast-downs, but is also useful in analysing steady state conditions as well. It is possible to set alarm circle and warning circles facilitating the process of making sure that the system keeps track of the stable phase. It is also possible for the user to add custom markers to highlight specific readings.

Figure 5 - 37 below, is an example of a polar display.

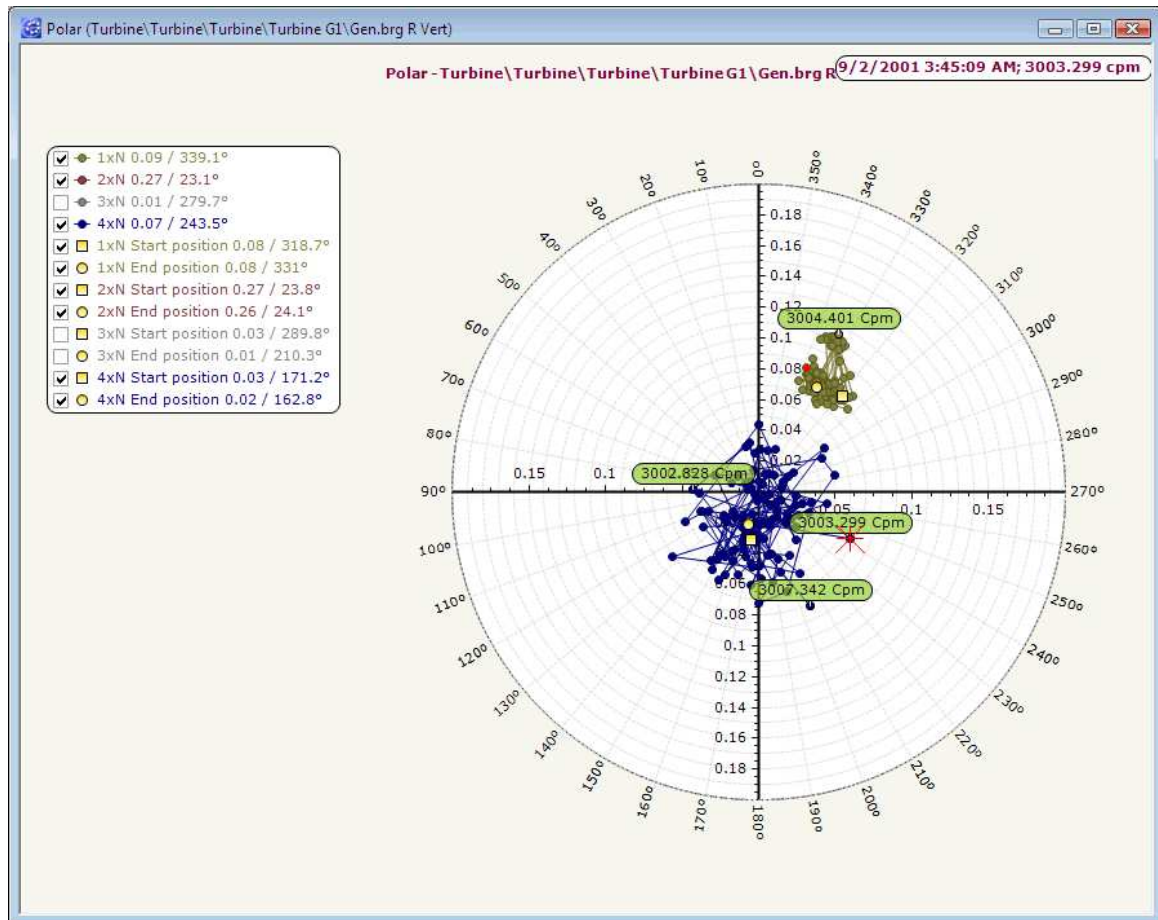

Figure 5 - 37.
Example of Polar Display.

Shaft Centerline



Use this icon to generate a shaft centerline display of a selected measurement point. The shaft centerline display shows the rotor position dynamically and is useful at run-up. Before the machine starts rotating, the shaft centerline display shows the shaft position to ensure that the shaft has an appropriate clearance at each bearing. When the shaft starts to rotate, the shaft position can be observed as the speed increases. To display shaft centerline data, a shaft centerline measurement point with two channels needs to be configured in @ptitude Observer. Set the shaft centerline cold gap by right-clicking in the hierarchy and selecting the option "Calibrate shaft centerline graph"

Figure 5 - 38 below, is an example of a shaft centerline display in a circular format.

Shaft centerline can also be displayed in a square format. The selection is made within [User Preferences](#).

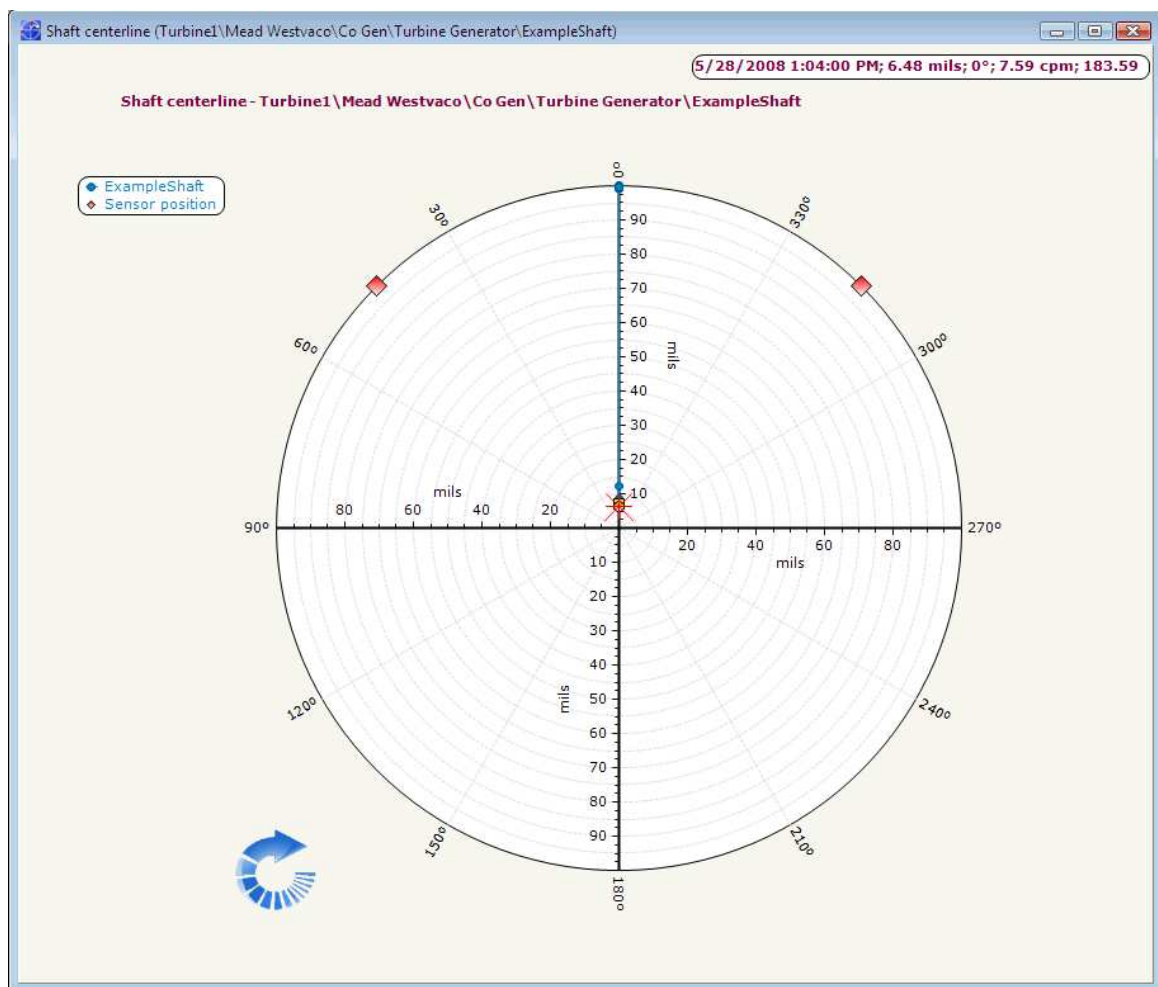

Figure 5 - 38.
Example of Shaft Centerline Display.

Combination Plots



Use this icon to display a list of available combination plots in the system. Combination plots show two or more types of diagrams for the same measurement. The individual parts of the combination plot often work cooperatively so once one part is zoomed, the other is also zoomed making it easier to follow the same type of data from two or more types of displays.

The following combination plots are available.

- **Spectra/Time waveform**
- **Spectra/Phase**
- **Trend/Spectra:** including an enhanced plot for spectral comparisons, see example.
- **Diagnosis/Spectra**
- **Diagnosis/Spectra/Time waveform:** this plot follows the cursor on the diagnosis plot and displays the simultaneous FFT and time waveform.
- **Trend/Spectra/Time waveform:** this plot follows the cursor on the trend plot and displays the closest FFT and time waveform.

Some combination plot examples follow.

Figure 5 - 39 below, is an example of a spectra and time waveform, combination plot.

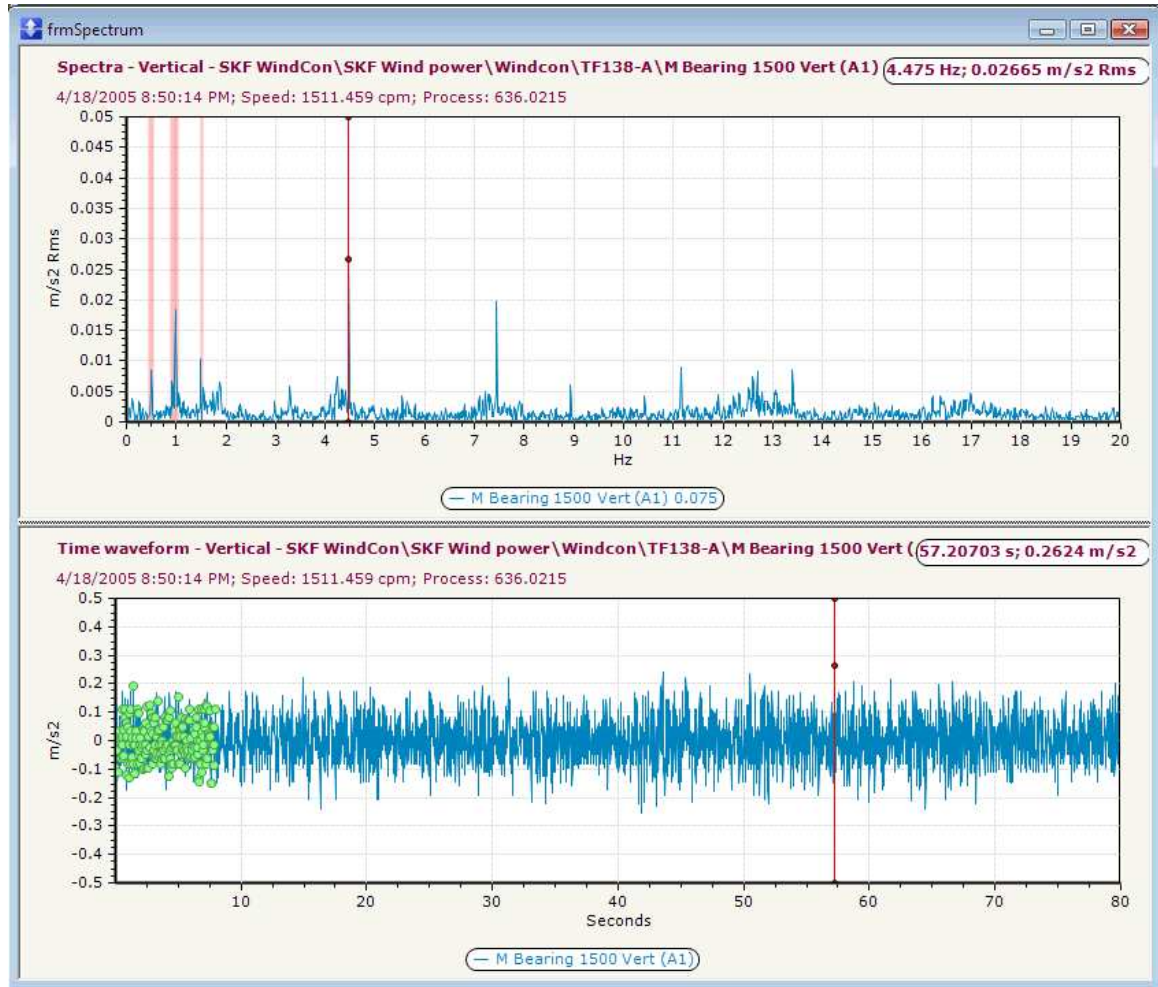

Figure 5 - 39.
Example of Spectra and Time Waveform Combination Display.

Figure 5 - 40 below, is an example of a trend and spectra, combination plot.

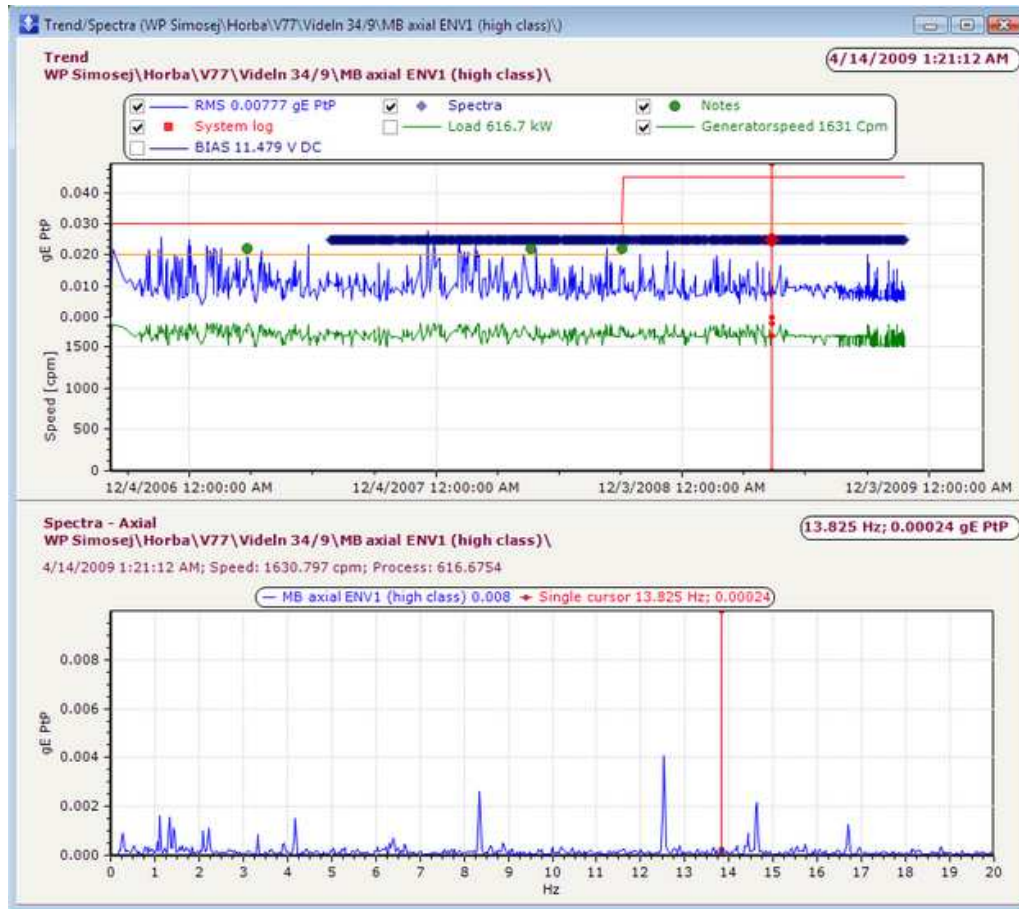

Figure 5 - 40.
Example of Trend and Spectra Combination Display.

When viewing a trend/spectra plot, it is possible to activate a secondary cursor on the trend and display a secondary spectrum plot, shown below the trend plot alongside the first (primary) spectrum plot:

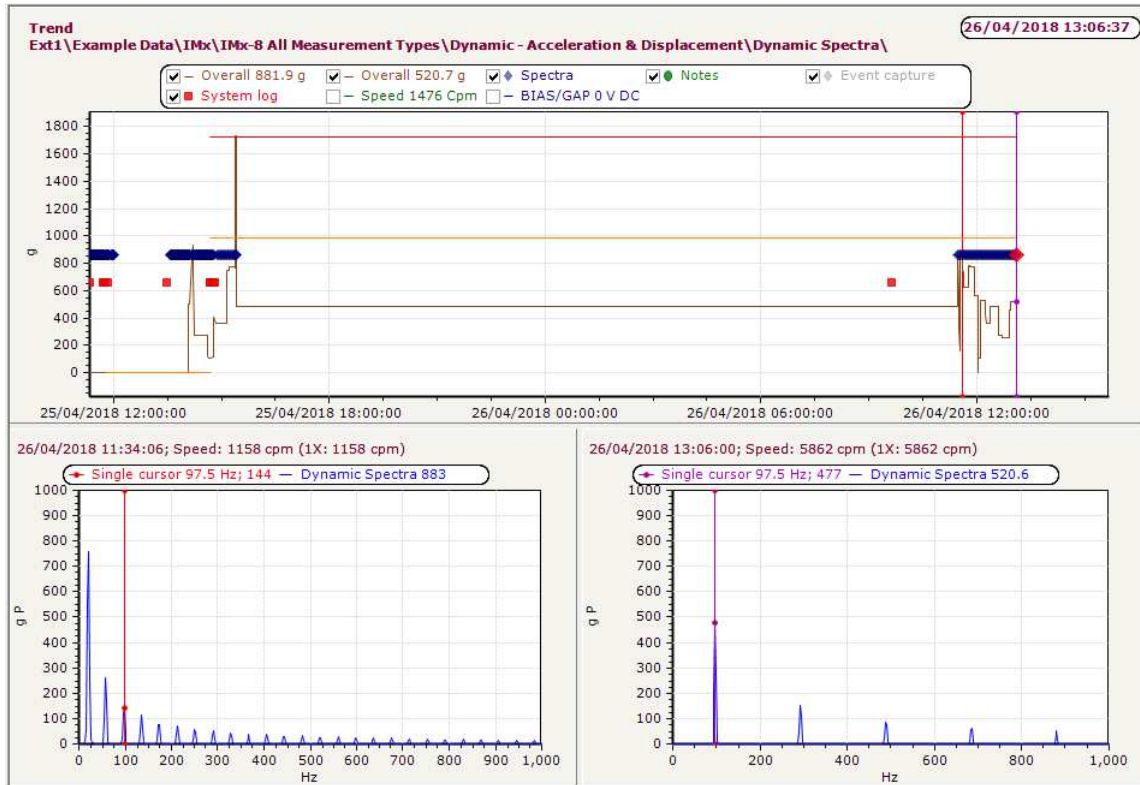

Figure 5 - 41.
Trend/Spectra Combination Display with secondary cursor enabled

The legend panel in the trend plot will show an additional set of values for the overall and up to four bands. Moving the new (secondary) cursor on the trend plot will change the spectrum displayed in the secondary spectrum panel (right hand side).

Control may be passed back to the original (primary) trend line in the trend plot by moving the mouse over that cursor line and clicking on it. Cursor control will then update the primary spectrum plot. It is possible to switch between the two cursors in this way, at any time.

Capture (Event and run cycle)



Event capture provides the capability to configure event capture groups with pre-and post-event, data capture. The captured time waveforms enable detailed analysis of both very low frequency (mechanical) and very high frequency (electrical or generator related) oscillations. Normal measurements taken at different sampling frequencies continue to operate as usual while a time waveform is collected.

Event captures can be triggered by the following:

- An alarm in the event capture group triggers event capture (for simple alarms).
- An alarm in the same alarm group as the event capture group triggers event capture (for complex alarms).
- Clicking the **Capture** button triggers a manual event capture.
- IEC status codes configured for event capture.

The following plots are available from the Event capture overview.

- **Event Capture Time Waveform** - the true peak-peak is calculated from the time waveform.
- **Event Capture 3D** – shows spectrum graphs taken from successive measurement values in the selected continuous time waveform capture. The z-axis represents time intervals in the event capture from which spectrum graphs were generated.

The following section describes working with the capture graph displays (event and run cycle captures). For details about the behaviour of the event capture function, refer to Appendix A, What to Expect When Using Event Capture in this user manual.

Run cycle captures can be used with IMx-8, IMx-16Plus or IMx-Rail devices, its specific use with IMx-Rail for rail track monitoring is discussed in Appendix D, SKF Rail Track Monitoring.

Displaying the capture view from the hierarchy

- From the hierarchy tree view, highlight a capture group. The capture view tool  in the toolbar is enabled.
- Click the capture view tool to launch the capture view.

OR

- Right-click a capture group and then select **Diagram**.

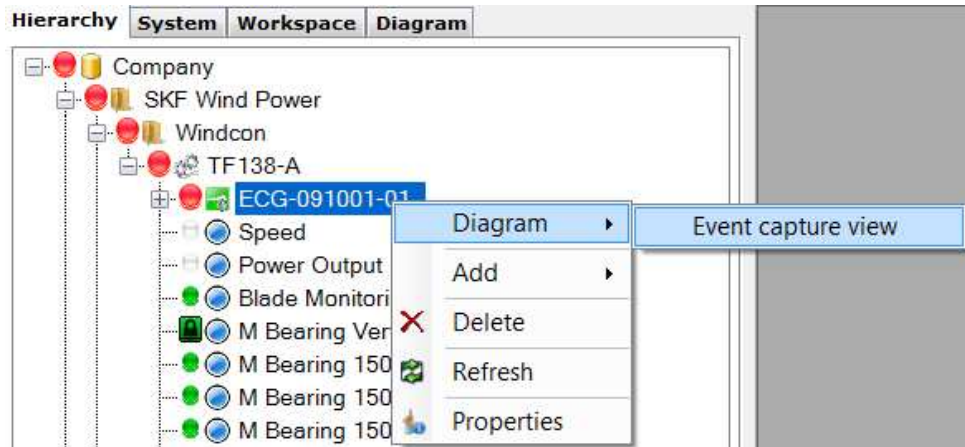

Figure 5 - 42.
Example of Diagram Options from an Event Capture Group.

- Select **Event Capture View**. The event capture view displays all points available in the capture. Each event capture point reflects a single channel.

From the hierarchy tree view, highlight an event capture point node and right-click to select **Diagram**.

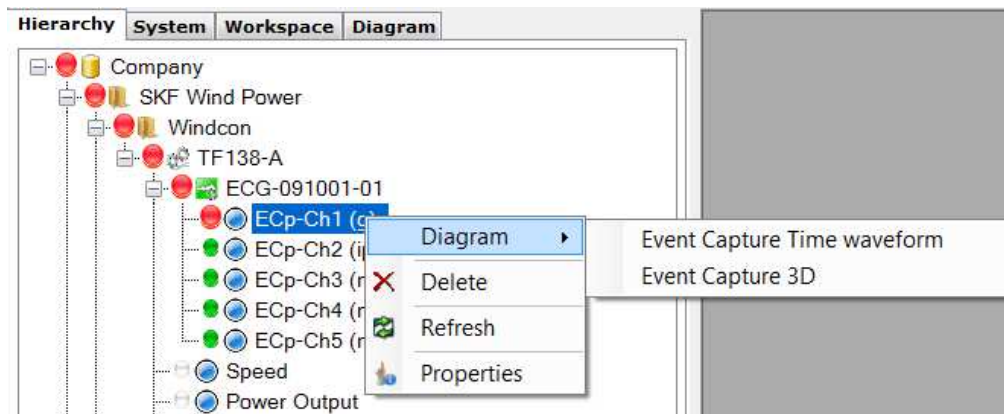



Figure 5 - 43.
Example of Diagram Options from an Event Capture Point.

- Select either **Event Capture Time Waveform** or **Event Capture 3D**. The event capture window displays the new time waveform or 3D plot showing only the selected point, if capture data is available. The Overview tab displays an overview plot for only the selected point.

The Trend plot function is enabled for event capture measurement points which have alarms enabled. Select the event capture measurement point in the

hierarchy view and then click Trend  to display the plot. The trend depicts event capture flags in the plot as grey diamonds. When an event capture indicator in the trend plot is clicked, a new window opens to display the corresponding event capture for further analysis. The list view selection shows the event that was selected on the trend plot and a thumbnail display of the same.

Initial event capture view description

Figure 5 - 44 below, is an example of the Event capture view.



Figure 5 - 44.
Example of Event Capture View.

The work space contains a list of the event captures taken for the event capture measurement group plus the overview of the time signal plots for the channels in the selected event group.

The captures list displays information for each event capture.

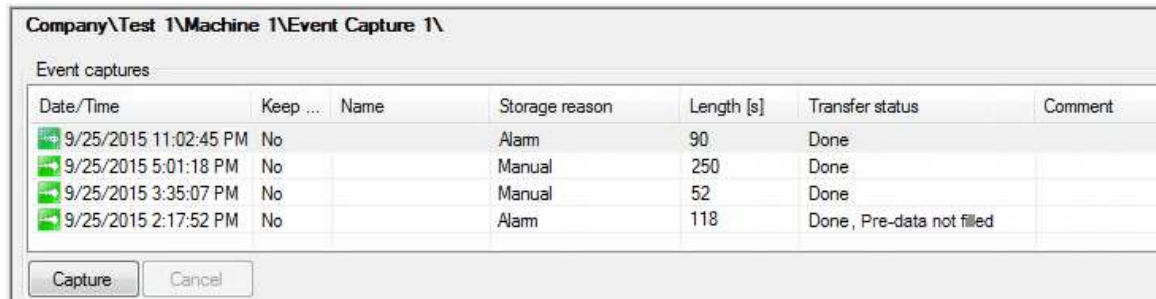

Figure 5 - 45.
Example of Event Captures List.

Date/Time when the event capture was triggered.

Keep Yes or No.

Name is the descriptive name given to the event capture.

Storage reason can be Alarm, Manual or Unknown.

Alarm - The event capture was triggered by the IMx due to an alarm.

Manual – The user clicked the **Capture** button to request the event capture.

Unknown - @ptitude Observer does not know yet if the incoming event capture is part of an alarm or a manual request.

Length [s] The actual length in seconds of the captured time signal.

Transfer status can be In Progress, Done, Truncated, Cancelled by user or Done, Pre-data not filled.

In Progress – the event capture is being received from the IMx.

Done – the event capture has received all expected data as configured on the measurement group.

Truncated - the event capture was closed because it could not be completed. The event capture may not have received the expected end packets for each channel's long time waveform signal or it may have lost sync for some reason.

Cancelled by user - the user clicked the **Cancel** button. When @ptitude Observer is connected to the Monitor Service, clicking this button will cause the IMx to restart and cancel the ongoing event capture.

An ongoing event capture cannot be cancelled if @ptitude Observer is not connected to Monitor.

Done, Pre-data not filled - the event capture did not receive all expected data as configured on the measurement group but it did receive all the data the IMx had to send.

Right-click on a plot in the overview to open the context menu.

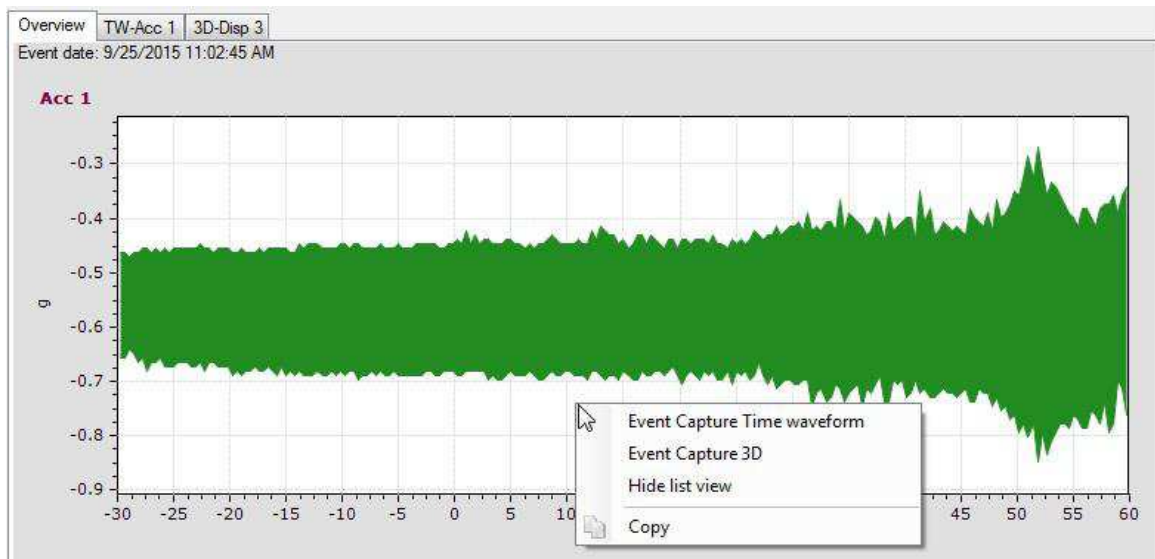

Figure 5 - 46.
Example of Event Capture Context Menu.

The menu options include:

Event Capture Time Waveform displays a more detailed window with the waveform of the long, time signal.

Event Capture 3D displays a 3D plot spectrum for the entire time waveform or a selection of it. The complete event or any part of it, can be analysed.

Hide list view hides the Event captures list section at the top of the workspace to provide more viewing space.

Copy creates a screenshot of the graph and copies it to the clipboard.

The window for the event capture contains three parts, as shown below:

- A. The complete or long, event capture
- B. A spectrum part
- C. A zoomed version

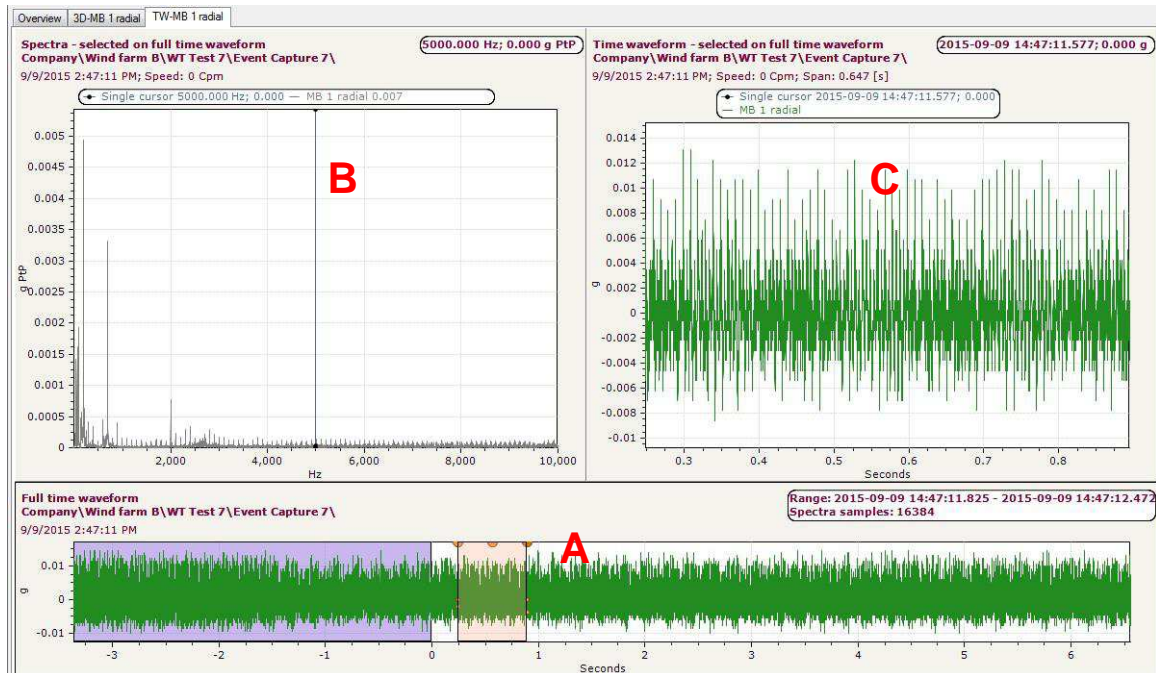

Figure 5 - 47.
Example of Event Capture Window.

The following rules apply to the complete or long, event capture (A):

- The occurrence of the event capture could be an alarm or manual storage.
- The date list of the event captures, if not hidden, shows the reason that storage took place: alarm or manual.
- One band marker is always visible and cannot be removed from the graph.
- The band marker controls both the length of the zoomed in time waveform and which values the spectra is going to be calculated on. The band in the full time waveform display is initially located at "0", which is the time the event occurred. The band can be adjusted to change the zoomed time waveform as the spectrum is recalculated.
- The X scale on the long, time waveform has zero time at the occurrence of the event capture storage. All time values before that are negative and positive after. The graph displays a different background colour for negative and positive time.

The following rules apply to the spectrum (B):

- Single cursors can be added to the spectrum.

- The DiagX tool can be applied to the active single cursor.
- The spectrum shows the fault frequencies calculated from the machine parts.

The **Event capture 3D** plot window displays the 3D plot and an event capture time waveform plot. The 3D plot shows spectrum graphs taken from successive measurement values in the selected continuous time waveform capture. The z-axis represents time intervals in the event capture from which spectrum graphs were generated. The lower time waveform plot shows the time range over which the event data was captured and indicates the range of data currently being displayed in the event capture 3D view.

The lower time waveform graph provides control points on a colorband cursor. Modifying the colorband cursor will cause the number of spectra being displayed to vary. Control points can be used to specify which part of the time waveform information displays its spectrum characteristics in the event capture 3D plot.

When opening an event capture 3D plot and moving the selected area on the long time waveform all the way to the right, there may be some data beyond the selected area that cannot be selected (shown as a grey band). This occurs because a sequence of spectra is calculated from the long time waveform. Depending on the number of samples required per spectrum, there may not be enough data to fill exactly each spectrum all the way to the end of the data. The display presents the areas of the long time waveform that are being used for spectrum data. Any data leftover cannot be selected. See **Spectrum Settings** below for ways to expand the area of selectable data.

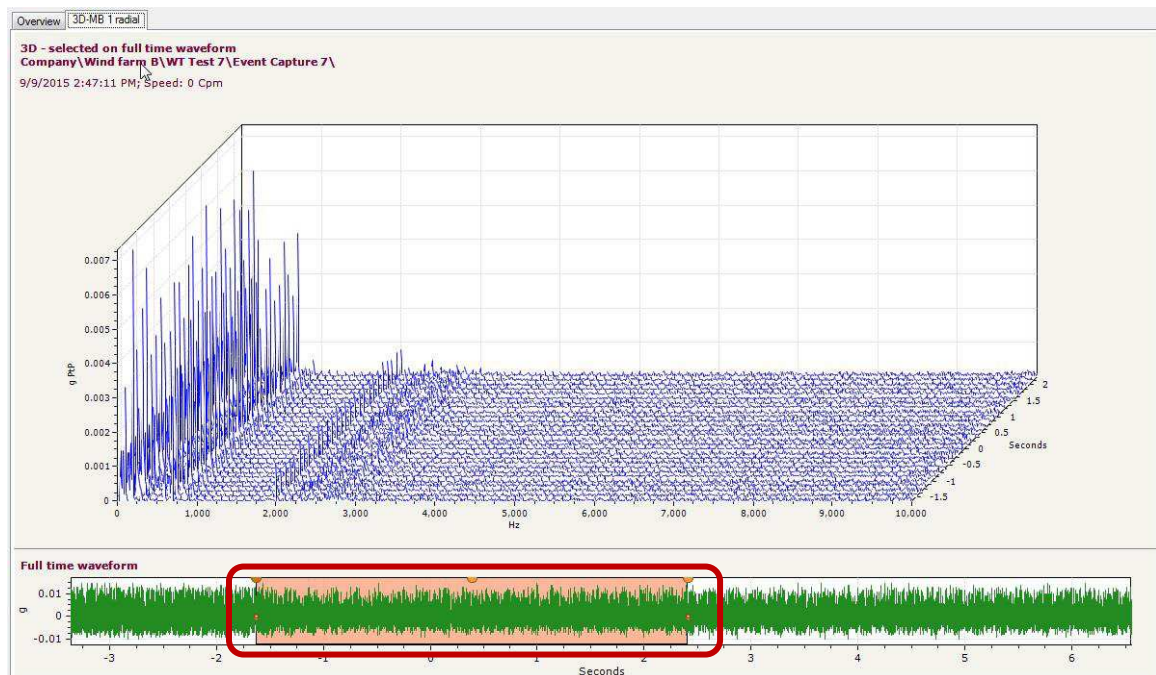

Figure 5 - 48.
Example of Event Capture 3D Plot.

Options Menu

The Option Menu is displayed when right-clicking on the forms. Relevant options differ in the event capture 3D plot and the event capture time waveform plot.

Right-click on the event capture 3D plot to open the following context menu.

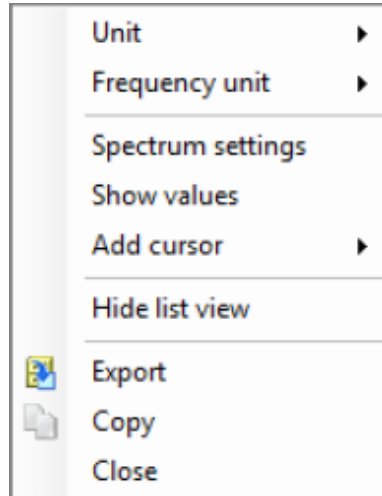

Figure 5 - 49.
Example of Event Capture 3D Plot Context Menu.

Unit is the measurement unit of the data displayed. Changes can be made between velocity, acceleration and displacement. The original measurement point units are restored when that particular graph is closed.

Frequency unit switches the frequency unit between Hz and cpm.

Spectrum Settings opens a dialog that controls how the spectrum graphs are displayed in the event capture 3D plot.

Change the **Fmax** by choosing from fixed Fmax settings. The Fmax can be modified only to a smaller or equal value to that originally taken in the event capture group. For example, if the event capture was measured with an Fmax of 1 kHz, the selection list will display only those choices that are 1 kHz or smaller.

Change the number of **Lines** shown in the spectrum graphs by choosing from the drop-down.

- This may affect the total number of spectra that are generated from the event data.

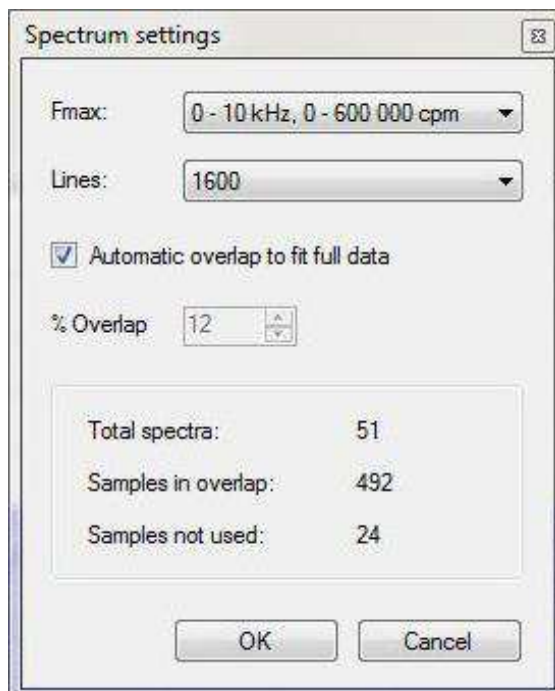

Figure 5 - 50.
Spectrum Settings Dialog.

The checkbox **Automatic overlap to fit full data**, is enabled by default. The system calculates the percentage of overlap that maximises the selectable spectrum information. The results of the automatic calculation display below: **Total spectra**, **Samples in overlap**, **Samples not used**.

Clearing the checkbox **Automatic overlap to fit full data**, allows manual adjustments to the **%Overlap** value to be made. **Total spectra**, **Samples in overlap**, **Samples not used** are recalculated and updated accordingly.

After making changes, click **OK**. New spectrum information is generated and the plot is redrawn to fit the new parameters.

Show values displays the values in 3D plots.

Add cursor adds available cursors (markers) one at a time in the graph temporarily.

Hide list view hides the Event captures list section at the top of the workspace to provide more viewing space.

Close To close a tab, right-click on the tab label and a small pop-up option to **Close** the tab displays. Or, use the context menu **Close** command.

Right-click on an event capture time waveform graph to open the following context menu.

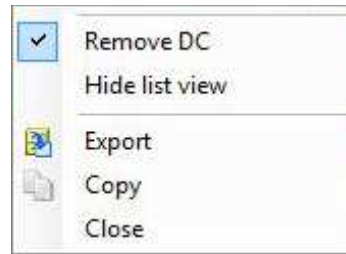

Figure 5 - 51.
Example of Event Capture Time Waveform Context Menu.

Remove DC provides the option to exclude the DC part of the signal. Often when showing time waveform data, the DC part is removed, leaving just the AC signal content.

To manually capture an event:

- Click **Capture** to initiate capturing an event. The event capture will display In progress as the **Transfer status**. While the capture is occurring, a message beneath the Event capture list states: Capture not allowed: capture is pending. When the capture completes, the status dynamically updates to **Done**. If the event capture cannot complete or no progress is detected for one minute, the capture attempt is ended and the status updates to Truncated.
 - The manual **Capture** function is not included in the count of maximum events stored per day. A manual event capture is stored even if the limit of event captures per day is reached.
 - The **Capture** function is unavailable when @ptitude Observer is not connected to a Monitor service or when the associated IMx unit is not available (connected). The following message is displayed to the right of the Capture button: Capture not allowed: Observer is not connected to the Monitor Service.
 - After the IMx has re-established communication with the Monitor service, there is a period of at least 60 seconds before the **Capture** button is re-enabled. The following message is displayed: Capture not allowed: waiting [number of] seconds on ready for event capture.
 - If a sensor cable problem (cable fault) occurs during the event capture, the following message displays: All or partial data stored out of sensor OK range.
- Another event capture may be initiated when the previous manual capture is Done or in any **Transfer status** except In Progress.
- Click **Delete** to delete a selected event capture from the list, provided that the **Transfer status** is not In Progress.

To edit an event capture:

- Select an event capture in the list and click **Edit** to open the **Edit event capture** dialog.

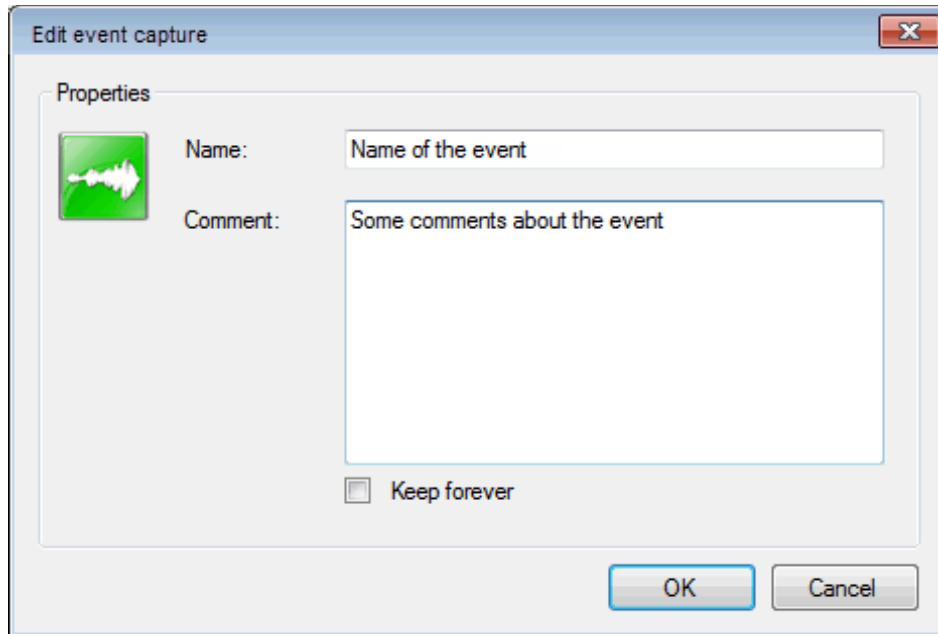

Figure 5 - 52.
Example of Edit Event Capture Dialog.

- Enter the **Name** of the event capture.
- Enter a **Comment**, if desired. The comment will display in the Events capture list.
- Select the **Keep forever** checkbox to save the event capture until the measurement group or measurement point is deleted. Event captures not marked as **Keep forever** can be deleted by the usual methods (the Delete Data interface or setting up the Automatically delete old data option under Database > Options)
- Click **OK**.

To export to UFF (Universal File Format):

- Select an event capture (with **Transfer status** Done or Truncated) in the list and then click **Export**. Only one event capture can be exported at a time.
- The **Export to UFF** dialog opens. The event capture **Group** name of the selected group is displayed. Specific-channels can be exported to a UFF.

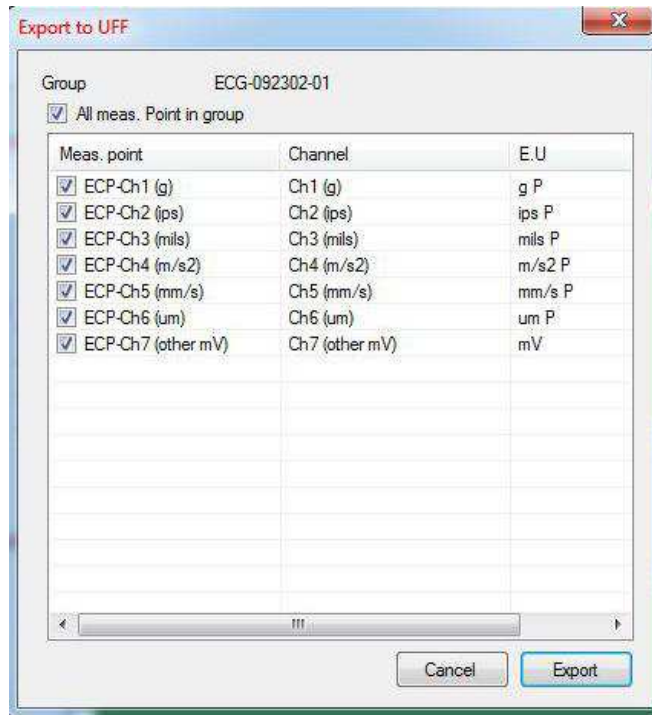

Figure 5 - 53.
Example of Export to UFF Dialog.

- The table contains the measurement points of the current selected group and measurement. **All meas. Point in group** can be checked to enable export of all the measurement points. Alternatively, check only the desired points within the table and uncheck those that should not be included.
- With the desired selections made, click **Export**. The UFF file is generated.

Buffer



This is the toolbar icon for the buffer selection and settings. The buffer is used to control and filter which data should be retrieved from the database for analysis. Date ranges, filter parameters and source buffer type, can all be specified.

Usage

Opening the buffer setting and changing any of the parameters will update the buffer for the active display only (the name of the buffer will change to 'custom').

To use these buffer settings in the future for opening graphs, click the save button. After entering a custom name for this buffer, it will be stored in the database and will be visible in the drop-down list of available buffers. Once selected, this buffer will then be used for any subsequent data retrievals.

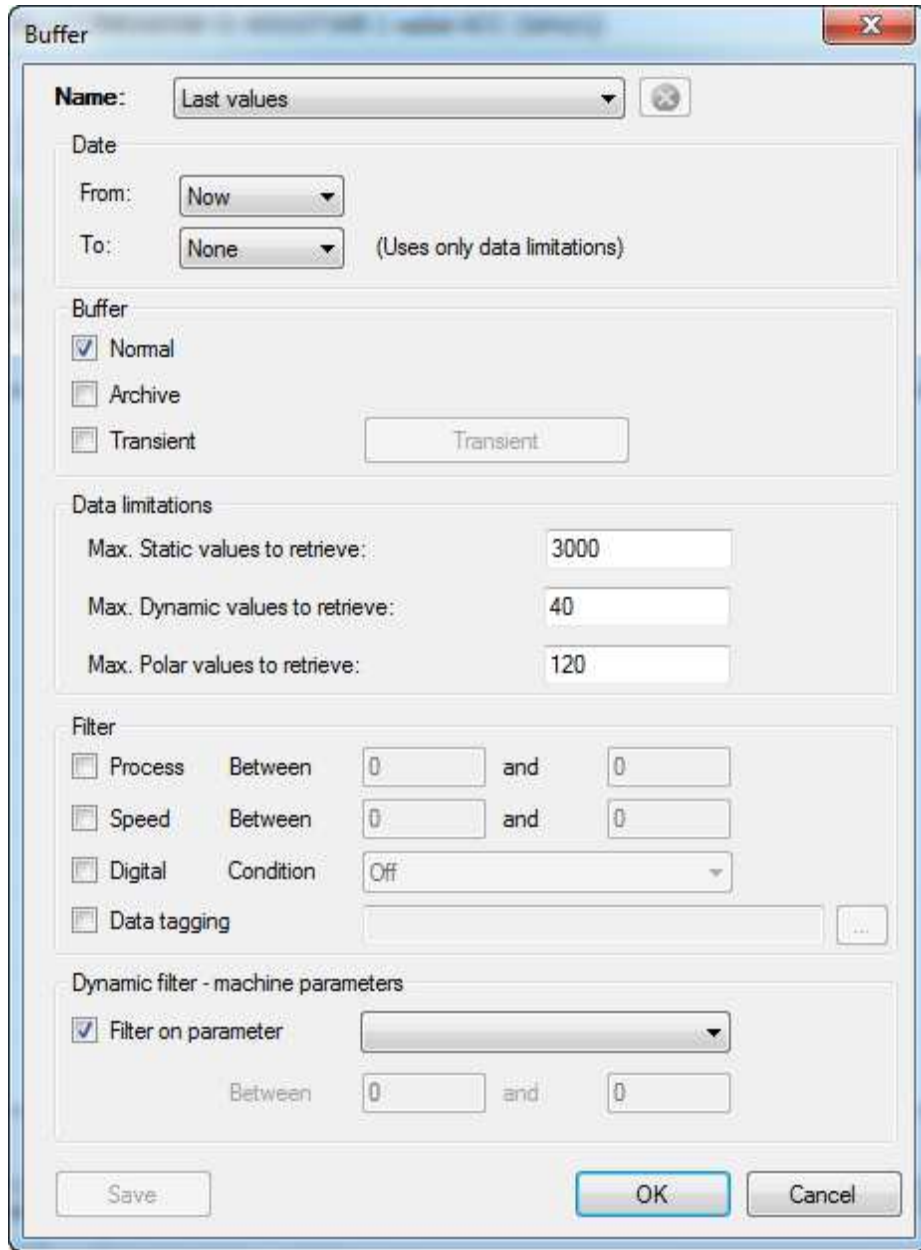

Figure 5 - 54.
Example of Buffer Settings.

Name identifies this particular setting of the buffer interface.

Date

Select a time or date from the pre-defined list to be used with Backward or Forward value for the end date range.

From specifies the start date and time.

To specifies the range of end date and time.

None

Now: specifies the current date and time for the end range.

Time: a specific time to define the end range.

Backward: specifies a date range backward in time relative to the start time. The pre-defined dates may be used for this option.

Forward: specifies a date range forward in time relative to the start time.

Buffer

It specifies from which buffer to collect the data.

Normal: refers to the data stored in the rolling buffer. The type of data and the storage interval are set in [Operating and Storage Conditions Tab](#) settings when creating a measurement point.

Archive: refers to the data stored in a special buffer called archive. This buffer typically stores one measurement data value every 10 minutes. At that rate, the 80 000 measurement data values it can hold would represent data collected over 1½years. The type of data and the storage interval are set in trend setting when creating a measurement point.

Transient: refers to the data captured during transient. Therefore, for this type of buffer, a specific transient of a measurement group must be selected.

Data limitations

Data limitations allow the user to enter the maximum number of values (Static, Dynamic and Polar) that should be retrieved.

Filter

Process allows filtering by process readings such as temperature and load. This is only applicable if the measurement point had an associated process point configured.

Speed allows filtering by speed readings. This is only applicable if the measurement point had an associated speed point configured.

Digital allows filtering by digital input on or off and filtering by the operating classes. This is applicable if the measurement point had an associated digital point configured.

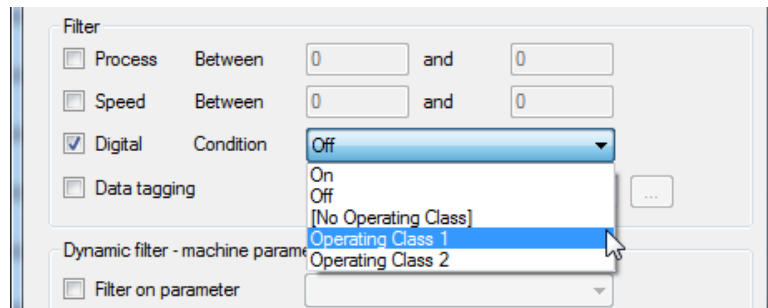

Figure 5 - 55.
Example of Buffer Settings for Digital Condition.

Data tagging allows for the filtering of data that is marked with a specific tag. Data can be tagged manually with a Software data tagging point or automatically by OPC data tagging points.

Dynamic filter – machine parameters

Filter on parameter enables, when selected (checked), the filtering of dynamic measurements in all relevant plot types based on the range set for

one selected machine parameter. Make a selection from the **Filter on parameter** list. The list contains the available machine parameters that are associated with the parent machine. Use **Between ___ and** to enter the minimum and maximum values for the filter. Either one or both must be entered. Upon clicking Enter, the plot will redraw using the new filter ranges specified by the parameters.

- If a box has no value, the filtering will have no limit in one direction. For example, if there is nothing in the minimum box then there is no lower limit on the filter.
- Unchecking the checkbox will clear the filtering and redraw the plot, but any values entered are still visible.

Notes

A note is defined as an observation or action taken, related to a machine. Typical notes relate to maintenance activities and visual inspections.

To get to Notes screen, select a machine then perform one of the following actions:

- Click on  **Notes** icon on the toolbar.
- Click **Edit** from the tool bar menu options, then select **Notes**.

The notes window displays the notes for the selected object in the hierarchy. Although a note is a machine-specific object, if an object of machine level or above is selected, then all notes under that object will be displayed.

It is possible to filter out specific notes based on date and title of notes. If a hyperlink is specified along with the note, then it can be opened by clicking the hyperlink for the selected note in the notes window. The notes window is automatically linked to the hierarchy. Therefore, selecting an item in the hierarchy updates the notes window automatically with the notes of the newly selected object.

Linking can be disabled by clicking  **link to hierarchy** icon on the toolbar. Use **New**, **Edit** or **Delete** options to configure notes.

Configuring a Note

Figure 5 - 56.
Example of Notes Settings.

Location indicates for which machine or measurement point the note is being configured.

Title enables categorisation of notes based on their type. To add a new title to the system click **Add** next to the title which brings up the new note title screen where a new title can be entered.

Date sets the date and time for the note. When creating a new note, the current date and time is set as default. However, the date and time may be altered to register for example, an historical event.

Priority specifies the severity level to categorise the notes.

Picture is a picture to be associated with the note.

Hyperlink is a document or webpage associated with the note where more information regarding the note can be found. This document or hyperlink can be accessed from the notes list window by clicking the hyperlink of the selected note.

Receiver specifies which group of users to receive the note. Groups are created by [Receivers](#) interface in Libraries under Database.

Comment is the informative text or content of the note.

Signature is the person who created the note.

Event Cases



Event cases can be created in Observer to keep track and document reports, information and history regarding a specific event tied to a specific machine.

New event cases can be created on machine level:

- Right-click on a machine from the hierarchy view then choose **Add Event case**.
- or select a machine, click the **Event cases** icon on the tool bar, then click the **New** button on the Event cases window.

The event cases window displays the event case reports for the selected object in the hierarchy. Although event cases are machine-specific, if an object of machine level or above is selected, then all event case reports under that object will be displayed.

Reports can be created to inform a customer or a department of actions that need to be taken care of regarding the event.

The reports are stored to the event case and can be reviewed and followed-up at a later date. The report is editable until the report is released by setting the status of the report to “released”.

Each report in the event case can produce a document at any time in word or .pdf format which can automatically be sent as an email and/or stored as an attachment on the machine.

A report contains a number of **assessments** which typically are used to inform customers or internal departments of important information by the data analysts in Observer. An assessment consists of an assessment text and a recommendation how to handle the information detected in the assessment.

A severity level can be set in the form of a “classification level” and the assessment can be tied to a specific machine part if desired.

To the assessments, **pictures** can be added which will also be printed in the document that can be produced from a report. These pictures are typically screen shots of graphs in Observer indicating a defect or problem of some kind, but any picture can be added.

Event case report layouts define how the documents should look. For more information, see [Report Library](#).

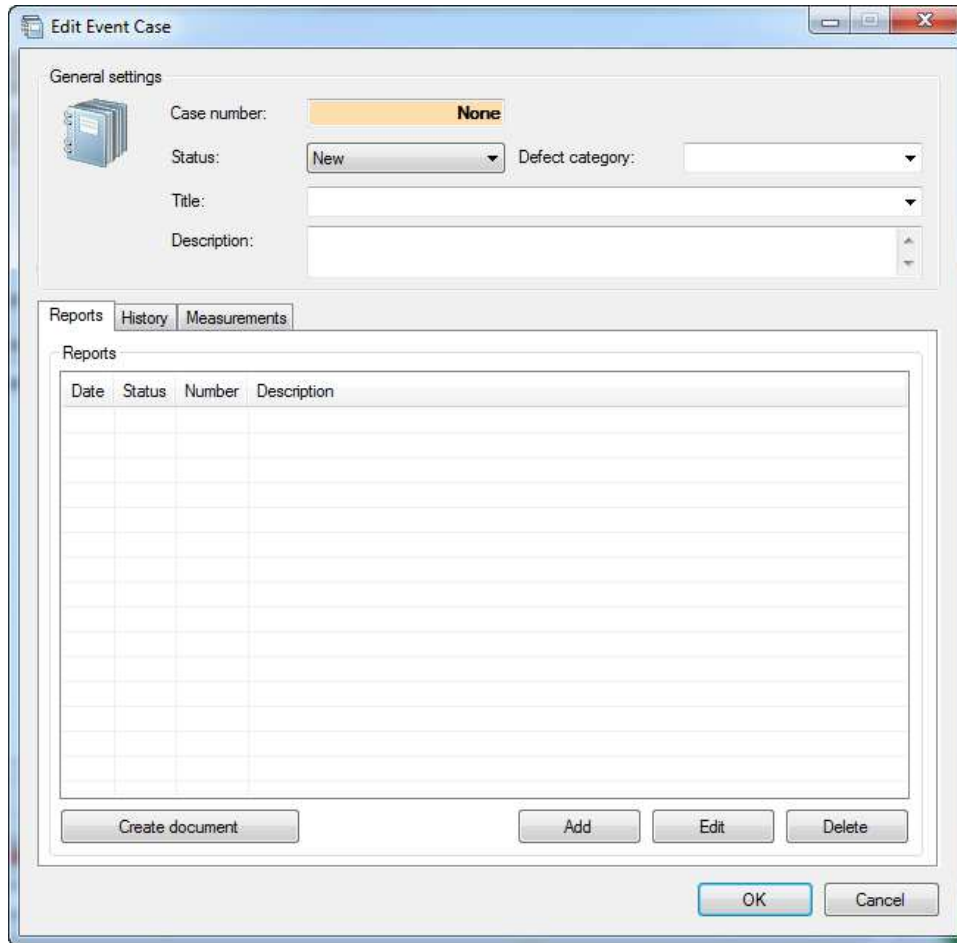

Figure 5 - 57.
Example of Edit Event Case.

Case number is a unique number that can be used to track this case. The case number consists of a counter and a prefix. The prefix can be set in the options interface. The case number in combination with the report number can be printed on the event case report documents that can be generated.

Status of the report.

Defect category can be used to group this specific case to a specific type of defect.

Title can be used to group this specific case with a specific title.

Description is a custom description that can be entered for the case.

Of all the above information, only the case number will be printed on any document generated from an event case report.

Reports Tab

Existing report(s) can be added, edited or deleted. A document can be generated by selecting a report and clicking **Create document**.

History Tab

It lists all the related history of the selected event case report. New history can be added or existing history can be edited or deleted.

Measurements Tab

Any measurements related to the selected event case report can be added, edited or deleted.

Editing an Existing Event Case Report

The screenshot shows a 'Report' dialog box with two tabs: 'General' and 'Pictures'. The 'General' tab is active and contains the following fields:

- Machine:** Machine 16
- Date/Time:** 11/ 8/2016 10:35:25 AM
- Status:** In progress
- Report number:** 1 **Modified:** 11/10/2016 10:36:18 AM
- Description:** Bearing cracked.
- Created by:** admin, admin
- Approver:** admin, admin

Below the general settings is an 'Assessments' section with a table:

Component	Classification	Assessment	Feedback topic
<Not selected>	1	Review	[None]

Buttons for 'Add', 'Edit', and 'Delete' are located below the table. At the bottom of the dialog are 'Create document', 'OK', and 'Cancel' buttons.

Figure 5 - 58.
Example of Report.

Machine displays the machine for which this event case report was created.

Date/Time sets the creation date and time of the report.

Status indicates the status of the report. Options are In progress, To be approved, Rejected and Released. When a report status is set to Released, the report cannot be edited any more.

Report number is an automatic number incremented by 1 each time a new report is created for the specific event case.

Description is a custom description that can be entered for the report.

Assessments lists all assessments created for the report. A new assessment can be added. Existing assessments can be edited or deleted.

Click **Add** or **Edit** to open the **Assessment** dialog.

Figure 5 - 59.
Example of Assessment.

Classification is used to classify the severity assessment in a scale from one to ten.

Machine part can be selected from the existing machine parts of the machine if this assessment applies to a machine part. It is also possible to enter a free text machine part.

Assessment is the data analysis detected or description of the event.

Recommendation of actions that need to be taken in response to the assessment.

Feedback topic specifies for which category the feedback has been provided (not editable).

Feedback displays the custom feedback (not editable).

Maintenance Planner

The **Maintenance planner** interface is for configuring maintenance tasks such as lubrication, replacements, scheduled maintenance etc. by keeping track of machine running hours or calendar time.

To get to the **Maintenance planner** screen, perform one of the following options:

- Right-click on a machine from the hierarchy view or workspace then select **Maintenance planner**.
- Select a machine, then click  **Maintenance planner** icon on the toolbar.

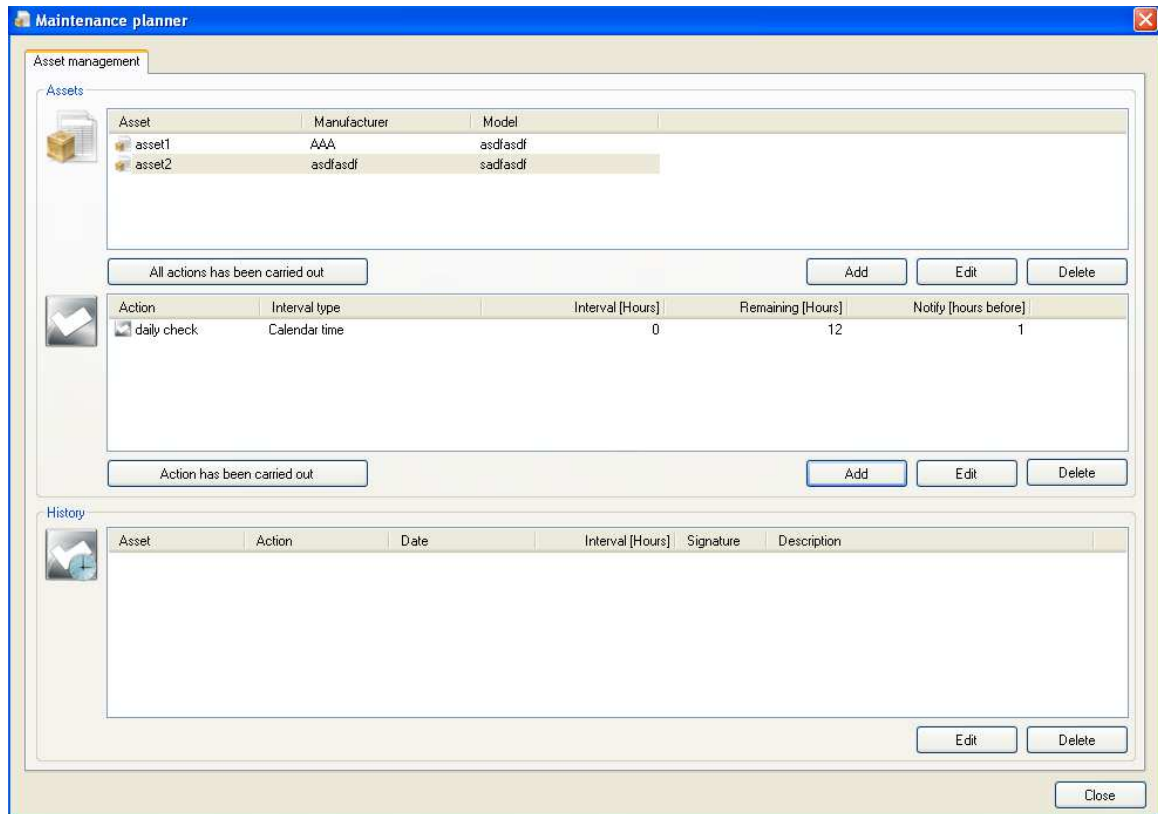

Figure 5 - 60.
Example of Maintenance Planner.

Asset management allows a user to add, edit or delete assets along with asset maintenance task actions. Note that an asset must be assigned first before a maintenance task action can be added, edited or deleted.

History displays the past maintenance tasks for the selected asset. History items can be edited or deleted.

Measurement Date



Measurement date interface lists the measurement date of the selected measurement point. It configures the storage information of the selected measurement data from the list.

Measurements list displays data information. Keep forever means that the selected measurement is set as a reference forever until it is edited otherwise.

Edit can change the date, time, option to keep forever or not, option to exclude from diagnosis, speed and process data.

Delete deletes the selected measurement data from the database.

Add can add data tagging specific information for Software data tagging points only.

Export ODS* data exports a selected measurement incident to a universal file format (UFF) which then can be imported into a software for machine movement animation such as ME'scope. *ODS: Operational Deflection Shape.

To open the **Meas. Date** interface, select a machine > select a measurement point > then click the Meas. date tool in the toolbar.

Date/Time	Total [g P]	Speed (Delta)	Process (Delta)	Digital	Storage reason	Data type	Mean. value	Exclude from diagnoses	Save	Buffer	Measurement Comment
6/23/2015 12:00:00 PM	0.109065	3720.041 (0.01)	0	0	Scheduled	Time waveform	1	No	No	Normal	
6/23/2015 11:59:00 AM	0.1081545	3720.04 (0.03)	0	0	Scheduled	Time waveform	1	No	No	Normal	
6/23/2015 11:58:02 AM	0.1106426	3720.04 (0.01)	0	0	Scheduled	Time waveform	1	No	No	Normal	
6/23/2015 11:57:01 AM	0.1112544	3720.04 (0.01)	0	0	Scheduled	Time waveform	1	No	No	Normal	
6/23/2015 11:56:01 AM	0.1133412	3720.041 (0.02)	0	0	Scheduled	Time waveform	1	No	No	Normal	
6/23/2015 11:55:01 AM	0.108332	3720.041 (0.02)	0	0	Scheduled	Time waveform	1	No	No	Normal	
6/23/2015 11:54:00 AM	0.1123144	3720.041 (0.02)	0	0	Scheduled	Time waveform	1	No	No	Normal	
6/23/2015 11:53:00 AM	0.1120982	3720.04 (0.02)	0	0	Scheduled	Time waveform	1	No	No	Normal	
6/23/2015 11:52:00 AM	0.1102406	3720.041 (0.02)	0	0	Scheduled	Time waveform	1	No	No	Normal	
6/23/2015 11:51:00 AM	0.1110953	3720.041 (0.02)	0	0	Scheduled	Time waveform	1	No	No	Normal	
6/23/2015 11:50:01 AM	0.1107337	3720.04 (0.03)	0	0	Scheduled	Time waveform	1	No	No	Normal	
6/23/2015 11:49:01 AM	0.1094539	3720.041 (0.02)	0	0	Scheduled	Time waveform	1	No	No	Normal	
6/23/2015 11:48:01 AM	0.1092161	3720.041 (0.02)	0	0	Scheduled	Time waveform	1	No	No	Normal	
6/23/2015 11:47:00 AM	0.1085987	3720.04 (0.01)	0	0	Scheduled	Time waveform	1	No	No	Normal	Status codes = 949
6/23/2015 11:46:00 AM	0.112321	3720.04 (0.03)	0	0	Scheduled	Time waveform	1	No	No	Normal	Status codes = 931
6/23/2015 11:45:01 AM	0.1112395	3720.04 (0.01)	0	0	Scheduled	Time waveform	1	No	No	Normal	Status codes = 927
6/23/2015 11:44:01 AM	0.1106753	3720.039 (0.03)	0	0	Scheduled	Time waveform	1	No	No	Normal	Status codes = 910
6/23/2015 11:43:01 AM	0.1109244	3720.039 (0.01)	0	0	Scheduled	Time waveform	1	No	No	Normal	Status codes = 890

Figure 5 - 61.
Example of the Meas. Date Window with Measurement Comments.

- Note that the [Buffer](#) can be used to control and filter what data is retrieved from the database into the **Meas. Date** window.

A Note about Measurement Comments and Status Codes

The final column is **Measurement Comment**. The comments displayed provide additional information to aid analysis, for example, IEC status codes. These IEC status codes can be requested and stored if the license module "IEC 61850" is installed. This license module applies only to the following devices: IMx-W, IMx-C, IMx-S, IMx-T, IMx-B, IMx-16Plus and IMx-8.

If a specific measurement shows IEC status codes in the **Measurement Comment** column, then the same status codes display when the measurement is opened in any graph. The status codes are also visible in printouts.

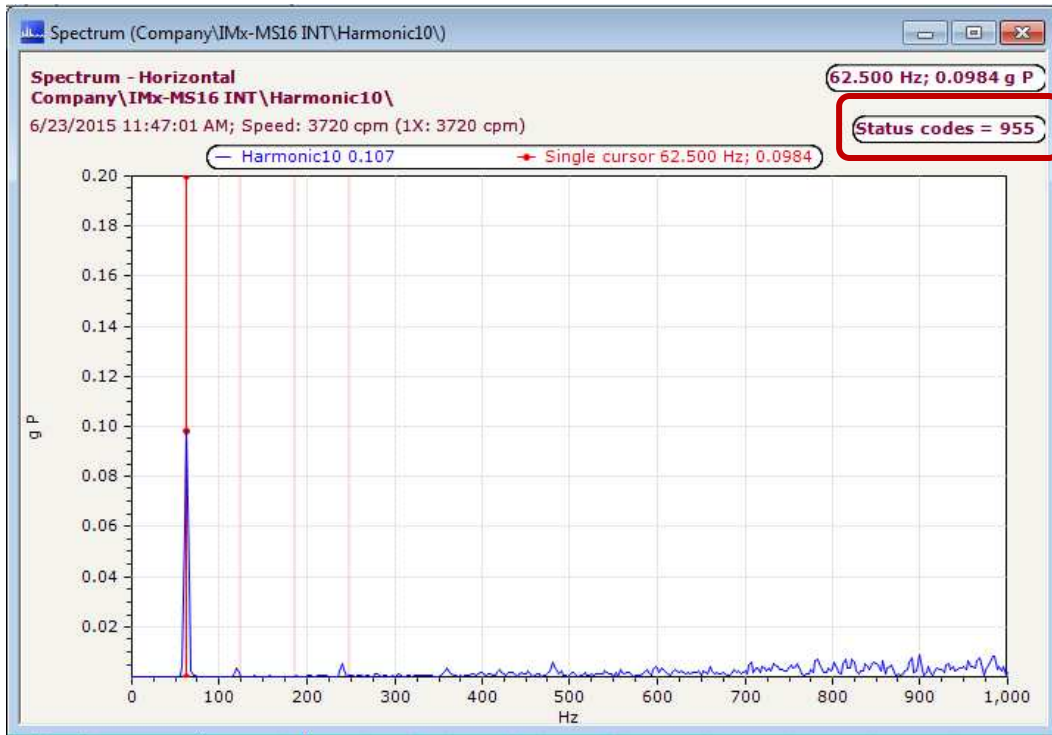

Figure 5 - 62.
Example of a Spectrum Plot with Status Codes Displayed.

6 Menu Items

The following are the menu items available in @ptitude Observer.

- [File](#)
- [Edit](#)
- [Show](#)
- [Database](#)
- [On-line](#)
- [Portables](#)
- [Window](#)
- [Help](#)

File

File menu provides the following interfaces.

- [Manage databases](#)
- [Add external database](#)
- [Remove external database](#)
- [Report](#)
- [Log off](#)
- [Exit](#)

Manage Databases

Manage databases interface provides the ability to connect to a database or jump from one database to another within @ptitude Observer without leaving the current log-on session. This is an important feature when data spread over several databases must be analysed. It is possible to add a new database and edit or remove an existing database.

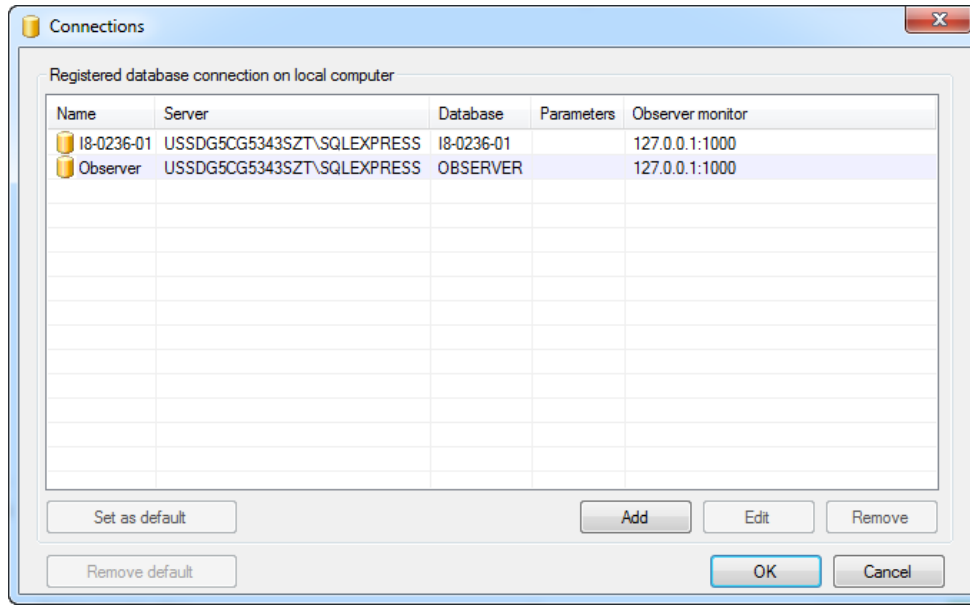

Figure 6 - 1.
Example of Database Connections.

Set as default sets a database as a default database with which the system starts.

Remove default removes the default database setting.

Adding/Editing a Database

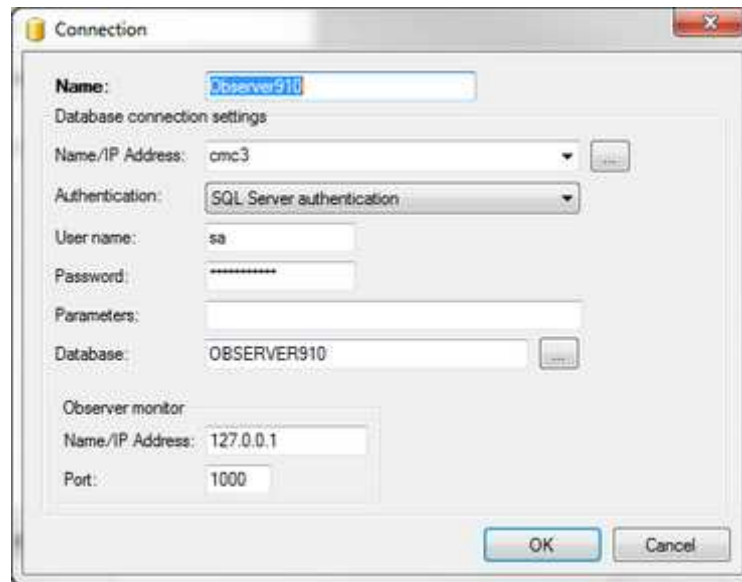

Figure 6 - 2.
Example of Database Connection Settings.

Name identifies the registered database connection on local computer.

Name/IP Address is the server name/IP address entered or selected from the list of detected servers. (local) refers to the computer on which @ptitude Observer is currently running.

Authentication is for SQL Server only. The choice is between Windows authentication and SQL Server authentication.

Windows authentication is applicable if connecting to an SQL server in the same domain as this computer with a common domain controller or if the SQL server is installed on the local computer.

SQL Server authentication should be used in all other scenarios.

User name is the database user name.

Password is the password for the user.

Parameters allows for any additional parameter to be applied to the database connection. For example, Network=DBMSSOCN means that the connection should be forced to use TCP/IP protocol. Auto translate=false can resolve DBCS character issues on systems with DBCS languages such as Korean, Japanese and Chinese.

Database specifies which database to use. Select a database from the drop-down list, this list includes all available @ptitude Observer databases on the specific database server.

Observer monitor settings are Name/IP address and Port of the @ptitude Observer Monitor that is serving the database server. This setting assigns which port the monitor should use to communicate with @ptitude Observer and IMx devices. The port default value is 1000.

The port setting should be the same number as the monitor service has been registered to run with using the "@ptitude Observer Monitor Manager" software.

Add External Database

Add external database interface adds an external database registration to the hierarchy. In an enterprise solution where it is common to work in several databases, it is convenient to add the databases as external databases which then enables access to all databases from the same hierarchy. The external database can be a database on the same database server or it can be on a different server.

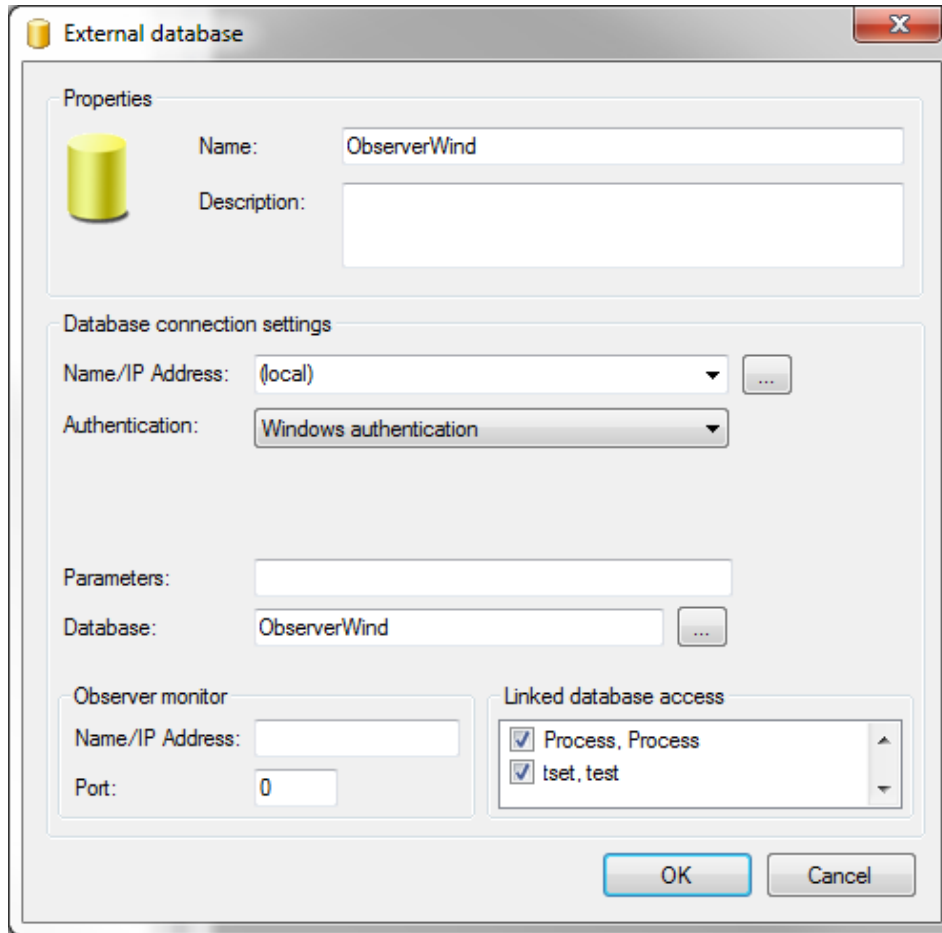

Figure 6 - 3.
Example of Add External Database.

Properties Name is what the external database should be called.

Properties Description is information about the external database.

The attributes of **Database connection settings** are the same as in [Connection](#) interface of Add/Editing a Database under Manage Databases.

Linked database access grants user(s) access to the specified external database.

Remove External Database

Remove external database removes the selected external database from the hierarchy view. Note that it is not possible to remove the main database.

Report

The Report interface can generate documents that contain text based information as well as diagrams and pictures of selected data.

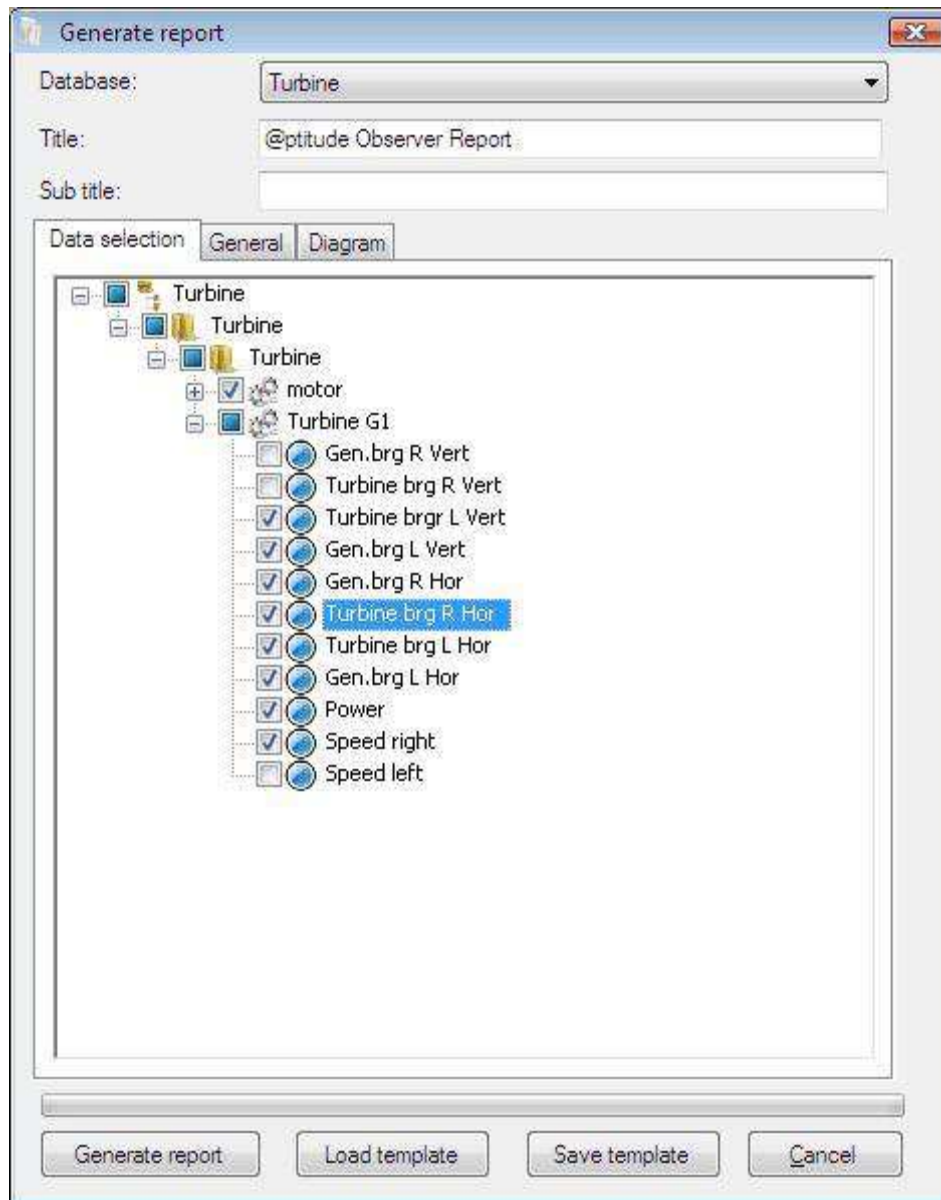

Figure 6 - 4.
Example of Select Data for Report.

Database is the database from which this report will be generated.

Title is an identifying name given to the report.

Sub title is a secondary, usually explanatory title.

Data Selection Tab

Data selection enables the selection of the machines and measurement points to include in the report.

General Tab

General sets formatting rules for the report and selects types of machine information that should be included. Different types of lists, like alarm lists can also be included.

Content prints the “Table of contents” at the beginning of the report, if checked.

Machine data prints the extended machine information for each machine included in the report, if checked.

Notes includes all the notes related to the selected machines during the date/time range entered, if checked.

Overall level includes the overall value list related to the selected measurement points from the date/time entered, if checked.

Alarm list includes alarm information related to the selected measurement points during the date/time range entered according to the filtering option and status option, if checked.

Page break between machines forces a page break on the printout between machines, if checked.

Show report automatically when generating shows the report in the selected format after the creation of the report has been finished, if checked.

Send report to printer sends the report immediately to a printer after it has been created, if checked.

Keep temporary files keeps all the temporary files required for the creation of the report including pictures, if checked.

Diagram Tab

Diagram allows desired graph settings to be included in the report, to be selected along with date or value range.

Load template loads report settings.

Save template saves current report settings as a template.

Log Off

Log off logs the current user off and allows another user to log on to the system.

Exit

Exit stops the current system session.

Edit

Edit menu provides the following interfaces.

- [Multiple point update wizard](#)
- [Workspace](#)
- [Copy node \(Ctrl+C\)](#)
- [Paste \(Ctrl+V\)](#)
- [Notes](#)
- [Event cases](#)
- [User preferences](#)
- [Properties](#)

Multiple Point Update Wizard

Refer to [Multiple Point Update Wizard](#) in System Configuration.

Workspace

Workspace interface brings up the workspace manager screen. A workspace is a specific part of the hierarchy that should be grouped together. For example, a workspace can be grouped by a user's responsibility. The workspace manager keeps track of all the workspaces in a database and can create new workspaces or edit existing ones. For portable data collectors, a workspace can be used as a way to define certain machines that the user needs to keep track of.

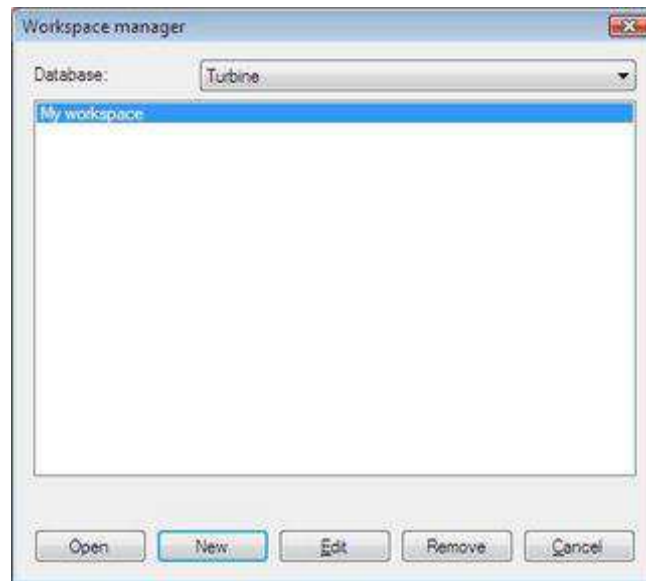

Figure 6 - 5.
Example of Workspace Manager.

Database is where the workspace resides.

Open displays the selected workspace from the workspace manager screen in the workspace view of tree view window.

New creates a new workspace.

Edit changes the currently selected workspace.

Remove can delete the workspace from the database.

Cancel closes the workspace manager window.

Editing a Workspace

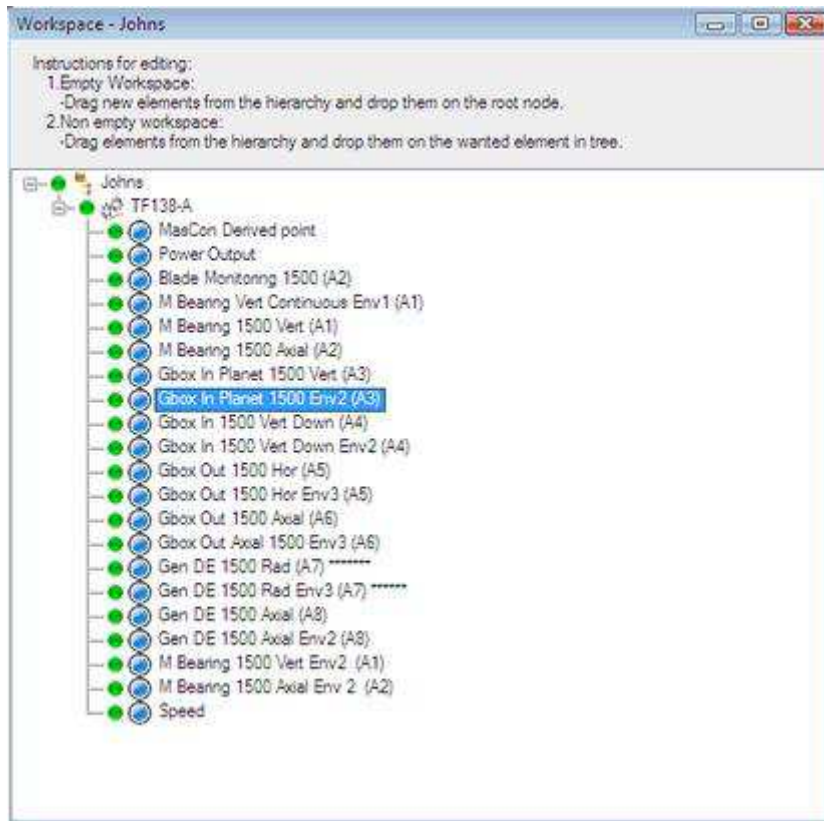

Figure 6 - 6.
Example of Workspace.

To configure the workspace contents, drag an element from the hierarchy view to the workspace on the location where the node should be positioned then drop it.

Available interfaces for different level of nodes are the same as in [Hierarchy View](#).

Copy Node

Copy node (Ctrl+C) copies the selected node. If a machine or a sub machine is selected, the machine copy wizard will start and guide the copying process. Refer to [Machine Copy Wizard](#) in System Configuration.

Paste

Paste (Ctrl+V) pastes the copied node to the selected location in the hierarchy view.

Notes

This displays a list of notes for the selected object in the hierarchy. Refer to [Notes](#) in System Operation.

Event Cases

Event cases can be created in Observer to keep track and document reports, information and history regarding a specific event tied to a specific machine. Refer to [Event Cases](#) in System Operation section.

User Preferences

User preferences interface is where all the customised settings for the individual users are set.

General Tab

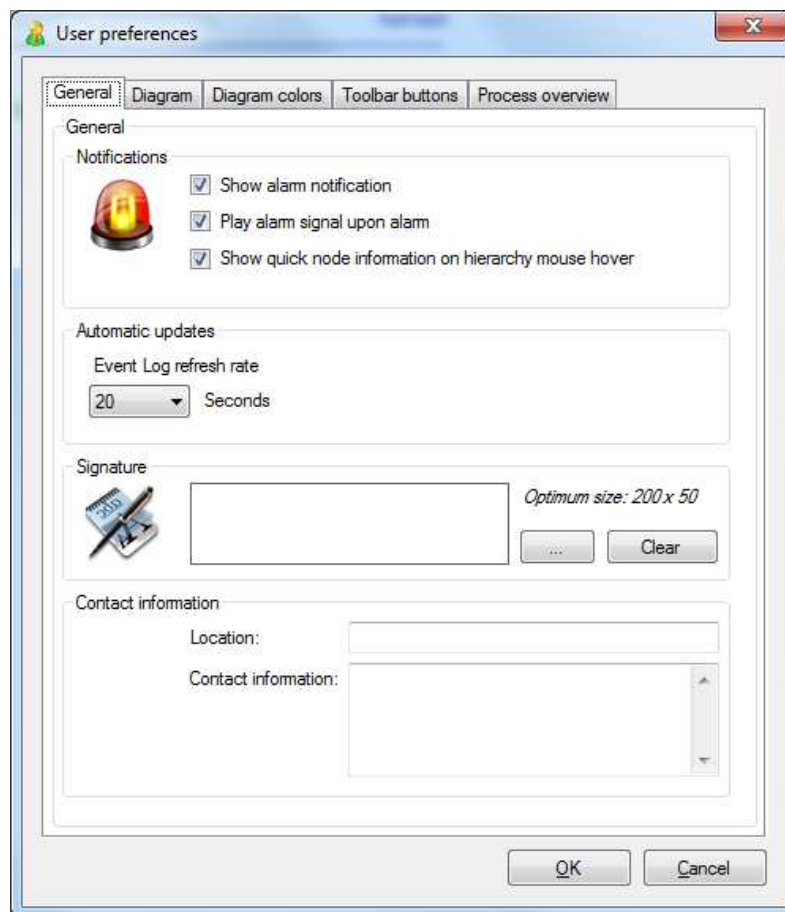

Figure 6 - 7.
Example of User Preferences Settings, General Tab.

Show alarm notification displays a flashing alarm icon on the top right corner of Observer screen upon alarm, if this field is checked.

Play alarm signal upon alarm triggers the sound through the speakers of the computer upon alarm, if this field is checked.

Show quick node information on hierarchy mouse hover enables the quick node pop-up information when hovering the mouse over a node in the normal hierarchy.

Event Log refresh rate tells the software how often the [Event Log](#) window shall be refreshed if it is open and the Auto refresh is enabled. **NOTE:** If this setting is set too low, then it will cause tremendous stress to the application as well as database.

Signature allows an image of a handwritten signature to be added. This signature can be automatically added to event case report printouts.

Contact information sets the contact information for the user.

Diagram Tab

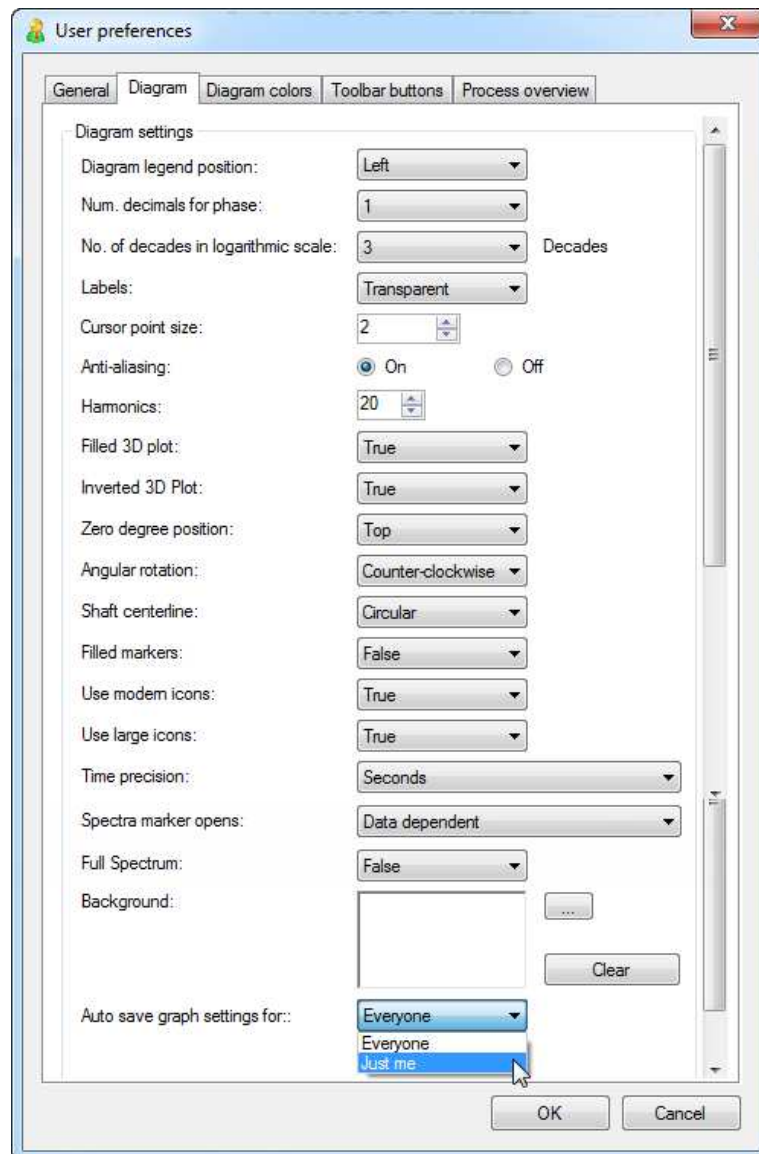

Figure 6 - 8.
User Preferences, Diagram Tab.

Diagram legend position sets the preferred position of the legend available in most graphs. Note that different legend positions are available for different types of graphs. If the specified position is not available for a particular graph then the software will choose and appropriately position it, automatically.

Num. decimals for phase sets the number of decimals to display for phase in the Trend, Polar and Trend List graphic displays.

No. of decades in logarithmic scale changes the way the logarithmic scale works for graphs. It can be between 2 and 5 decades.

Labels determines how to display labels in graphs. Labels can be set to be displayed as transparent as well.

Cursor point size sets the size of the cursor points for single cursors and other tools mostly for the phase spectrum and time waveform graphs.

Anti-aliasing determines if graphs should be displayed with smoothing (anti-aliasing) On or Off. Some users prefer to display graphics in any application as anti-aliased. However, in order to analyse data sometimes it is easier to detect a problem with anti-aliasing off.

Harmonics sets the number of harmonics for the harmonic cursor. It can be between 10 and 200.

Filled 3D plot

True fills the spectrum area as shown in the 3D plot graph display.

False makes the areas transparent.

Inverted 3D Plot inverts the depth scale of the 3D plot.

Zero degree position is the position of 0° in Polar type plots.

Angular rotation determines which direction of the angle increase in Polar type plots.

Shaft centerline determines if the shaft centerline plot should be visualized in circular or square format.

Filled markers shows the point markers as filled or transparent in some diagrams

True shows the point markers as filled, in some graphic displays.

False shows the point markers transparent, in some graphic displays.

Use modern icons shows modern icons if checked True. Otherwise older versions of icons are displayed.

True displays modern icons.

False displays older version of icons.

Use large icons shows bigger icons if checked True. Otherwise, the system displays small icons.

Time precision sets the precision of the time displayed in the plots.

Spectra marker opens sets the preferred plot type to open when the user clicks the left mouse button on a 'diamond' marker in the trend plot. If the specific measurement does not contain enough information to render the preferred plot, the software will automatically choose the most appropriate plot. Right-clicking on the 'diamond' spectra marker in a trend plot allows the user to pick from a selection of plots to open.

Full spectrum sets the preferred spectrum mode to be opened when displaying spectra in the application. If set to 'true', the application will display the data opened in plots in Full Spectrum mode if the measurement and measurement point support it.

Background specifies the background image of graphs. The default is watermark image.

Auto save graph settings for sets the preferred scope of the graph setting changes. The default is Everyone, which shares the graph settings with all users. If set to Just me, then the graph settings are private and saved only for the current user.

Diagram colors Tab

Here are all the available colour options for the graph. All can be changed: from the background colour of the graph to the colour of tools.

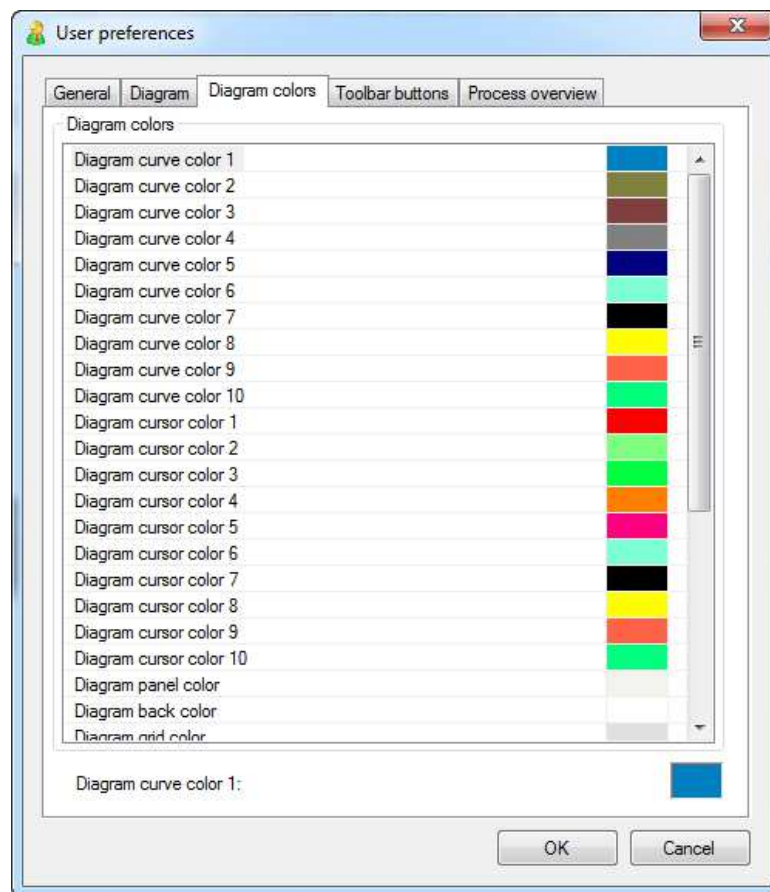

Figure 6 - 9.
User Preferences, Diagram Colors Tab.

Toolbar buttons Tab

This tab determines the toolbar buttons to be displayed.

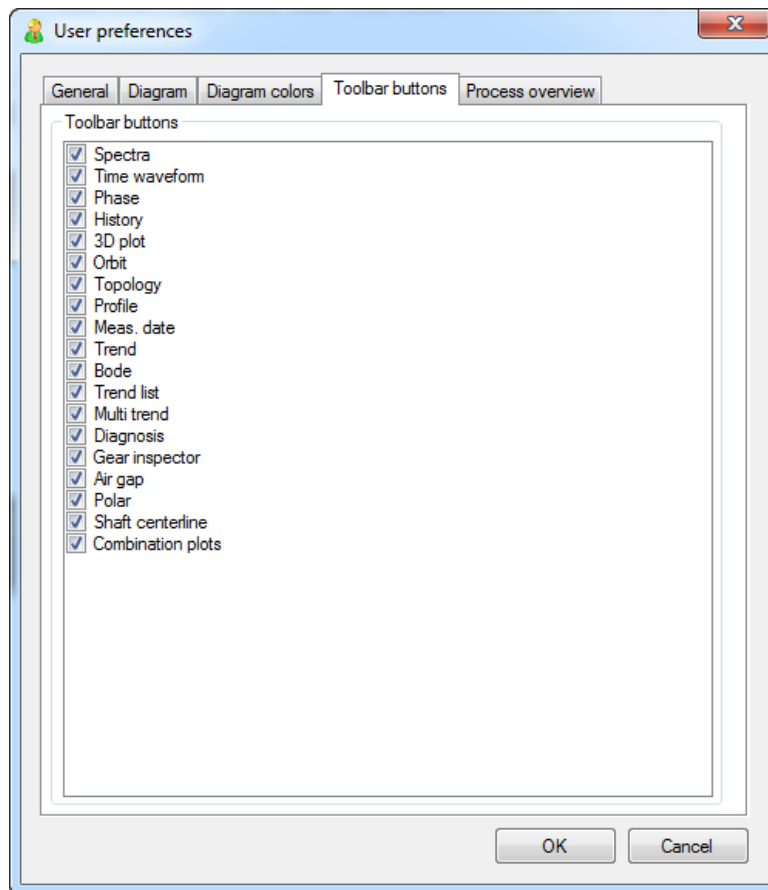

Figure 6 - 10.
User Preferences, Toolbar Buttons Tab.

Process overview Tab

Some of the Process Overview user preference settings can be customised, to enhance viewing the Process Overview. For example: by selecting to enlarge the icons, setting the update rate and changing the colours of the background and text. **User preferences** can be accessed from either **Edit > User preferences** or by right-clicking in the Process overview and selecting **User preferences**.

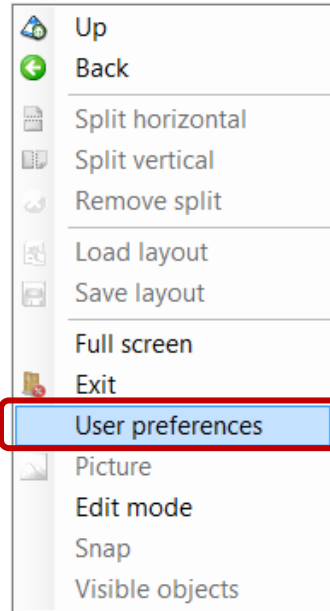

Figure 6 - 11.
Right-Click Context Menu, Edit Mode and User Preferences.

To customise the Process overview settings:

- In the **User preferences** dialog, click the **Process overview** tab to open it.

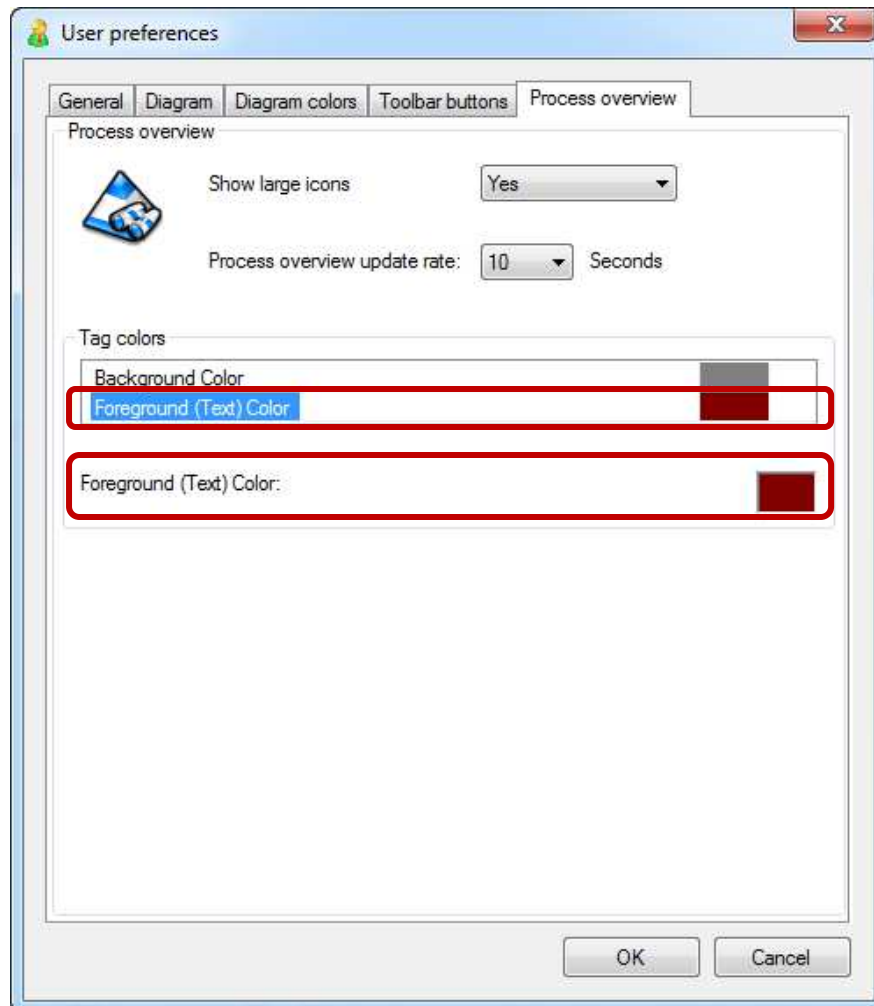

Figure 6 - 12.

User Preferences, Process Overview Tab – changing text colour.

- Selecting **Yes** for **Show large icons**, will maximise the status icons. With this option, the status icons expand in size proportional to the overall size of the tag (details are presented below). If **No** is selected, the status icons remain normal size.
 - Note that the maximum size of a status icon is 100x100 pixels.
- **Process overview update rate** can be set between 1 and 30 seconds. This tells the software how often the process overview display should ask the @ptitude Observer Monitor computer for new values to display in the process overview.

⚠ WARNING! If this value is set too low, it will cause tremendous stress to the application as well as the database.

In the **Tag colors** section, the background or foreground (text) colour can be changed.

- Click on the text portion of the label **Background Color**. Notice that label below for the picture box also says **Background Color**.
- Click on the picture box to open the **color control dialog**.

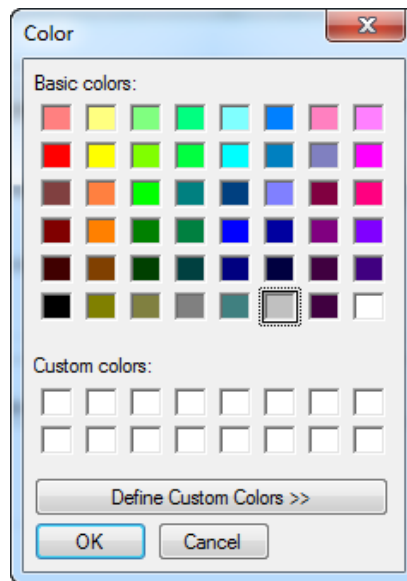

Figure 6 - 13.
Color Control Dialog.

- Select the desired background colour and then click **OK** in the dialog. The colour in the picture box and in the color box of the **Background Color** row update to the selected colour.

Change the text colour in the same way:

- Click on the text portion of the label **Foreground (Text) Color**. Notice that label below for the picture box also says **Foreground (Text) Color**.
- Click on the picture box to open the **color control dialog**.
- Select the desired text colour and then click **OK** in the dialog. The colour in the picture box and in the color box of the **Foreground (Text) Color** row update to the selected colour.
- Click **OK** to save the new **Process overview** user preferences.

Back in the workspace, the tags will reflect the new background and text colour selections.

To manually enlarge the tags:

- If **Show large icons** is set to **Yes**, select a tag and catch the corner(s) to manually enlarge it. Catch the lower right corner (a diagonal arrow appears) to enlarge the tag both vertically and horizontally. When an arrow appears at the bottom edge, the tag can only be stretched vertically and when an arrow appears at the right edge, the tag can only be stretched horizontally.
 - The maximum size of a status icon is 100x100 pixels.



Figure 6 - 14.
Example of an Enlarged Process Overview Icon/Tag.

Properties

This interface provides properties of the selected item in the hierarchy view, system view or workspace view.

For measurement point properties refer to [Setting up Measurement Points and Alarms](#) in System Configuration.

For machine properties refer to [Machine Properties](#) under Creating IMx/MasCon Devices and Channels in System Configuration.

For node properties refer to [Node](#) under Building a Hierarchy View in System Configuration.

For database properties refer to [Add External Database](#) under File in Menu Items.

Show

Show menu provides the following interfaces.

- [Tree view](#)
- [Filter](#)
- [Hierarchy](#)
- [System](#)
- [Workspace](#)
- [Diagram View](#)
- [Alarm list](#)
- [System alarm](#)
- [Maintenance Overview](#)
- [Message Center](#)
- [Refresh](#)
- [Dashboard](#)

Tree View

Tree view shows or hides the tree view window containing the hierarchy view, system view, workspace view and diagram view. Refer to [Tree View](#) in System Operation. Hiding the tree view window provides more area available for graphs on the screen.

This interface can also be accessed by clicking on  **Show tree view** icon on the toolbar.

Filter

This interface filters the hierarchy view according to the specified rules.

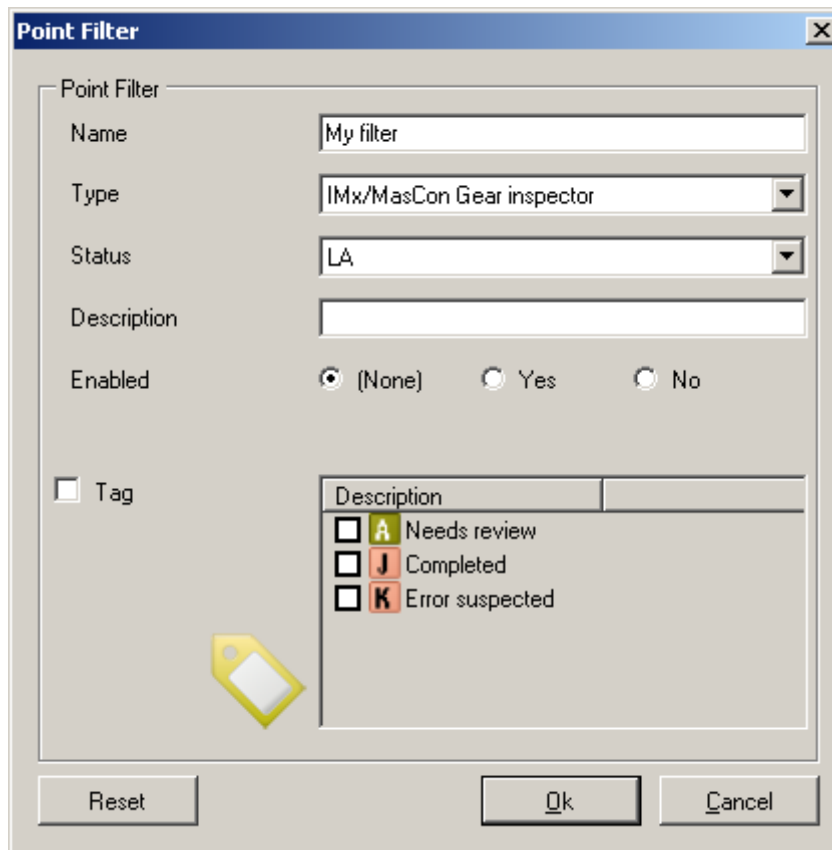

Figure 6 - 15.
Point Filter.

Name is the name of the filter.

Type is the type of points to be included, selected from the drop-down list.

Status is the status of points to be included, selected from the drop-down list.

Description is a description for the points included.

Enabled is used to filter based on the point's enabled state.

None displays all the points regardless of their enabled state.

Yes displays only the points that are enabled.

No displays only the points that are disabled.

Tag is used to filter by the selected tag(s).

Reset sets filter settings back to the system generated settings.

Hierarchy

Hierarchy view brings up the hierarchy view in the tree view window. Refer to [Hierarchy View](#) under Tree View in System Operation.

System

System brings up the system view in the tree view window. Refer to [System View](#) under Tree View in System Operation.

Workspace

Workspace brings up the workspace in the tree view window. Refer to [Workspace](#) under Tree View in System Operation.

Diagram View

Diagram View brings up the hierarchical view of saved diagram boxes in the tree view window. Refer to [Diagram View](#) under Tree View in System Operation.

Alarm List

Alarm list interface brings up the alarm list for the selected item in the hierarchy view and displays all the alarms under this item and sub-items in the alarm list.

The alarm list can also be opened by clicking on  **Alarm list** icon on the toolbar.

By default, the alarm list is linked to the hierarchy view. Therefore, the alarm list gets refreshed every time a new node is selected in the hierarchy view. The link status is indicated by [Alarm list(Linked)] keyword on the top of the screen.

The link can be turned off by clicking on  **link to hierarchy** icon on the toolbar.

Filter

Not acknowledged: the alarms that have not been recognized and not analysed by any user yet.

Acknowledged: the alarms that have been acknowledged by any user.

None: all alarms regardless of the acknowledgement status.

Acknowledge all acknowledges all the alarms.

Acknowledge acknowledges only the selected alarm(s).

Refresh reloads the alarm list.

Print prints the alarm list.

Alarm list can be sorted by any column.

System Alarm

The System alarm interface shows measurements out of range and system related alarms such as defective sensors, cables, etc. In addition, the @ptitude Observer Monitor start-ups and a loss of contact between an IMx/MasCon device and the @ptitude Observer Monitor are registered as well. This is a good place to start for troubleshooting a hardware error.

System alarms are categorised into 'Normal' system alarms and 'critical' system alarms. The critical system alarms are more severe and require more attention from the user than normal system alarms. If a critical system alarm is registered in the system, the system alarm icon in the toolbar will start blinking to attract attention. Upon opening the system alarm list, an additional list will be displayed in the top listing the critical system alarm.

System alarm list can be sorted by any column. The attributes of the system alarm settings are the same as in [Alarm List](#), above.

Maintenance Overview



Maintenance overview interface enables review of the maintenance tasks scheduled in the future. Maintenance tasks can be reviewed irrespective of whether they have been notified but not yet actioned or they are overdue. A description of how to set maintenance tasks is found in [Maintenance Planner](#) under System Operation section.

Message Center

Message Center interface enables the user to send/receive messages to/from other users within Observer. This can be a helpful tool for those who work in the same database to notify and communicate with each other.

Refresh

This interface forces a refresh of the hierarchy view, system view or workspace

view. Refresh can also be accessed by clicking on  **Refresh** icon on the toolbar.

DASHBOARD

"DASHBOARD" screen provides Notifications, News Feed and Message Center interfaces which can be navigated by clicking on icons in the upper right-hand corner of the dashboard screen.

Notifications displays any notifications that the user should be aware of.

News Feed informs users of new features in the currently released version. It is also accessible via [News in Observer](#) under Help menu tab.

Message Center enables the user to send/receive messages to/from other users within Observer. It is also accessible via [Message Center](#) under Show menu tab.

First time access to Dashboard displays Notifications.

The subsequent access to Dashboard displays one of three above interfaces that has been accessed most recently.

Database

Database menu provides the following interfaces.

- [Security Roles](#)
- [Users](#)
- [Database information](#)
- [System log](#)
- [Pictures](#)
- [Diagnoses](#)
- [Libraries](#)
- [Export](#)
- [Import](#)
- [Alarm group](#)
- [Measurement groups](#)
- [Options](#)
- [Delete data](#)
- [Data miner](#)

Security Roles

Security roles are pre-configured groupings of user rights. User rights are privileges of the user. Privileges are assigned by the system according to the role.

In the **Security roles** dialog, select a Security Role **Name** from the list of standard roles.

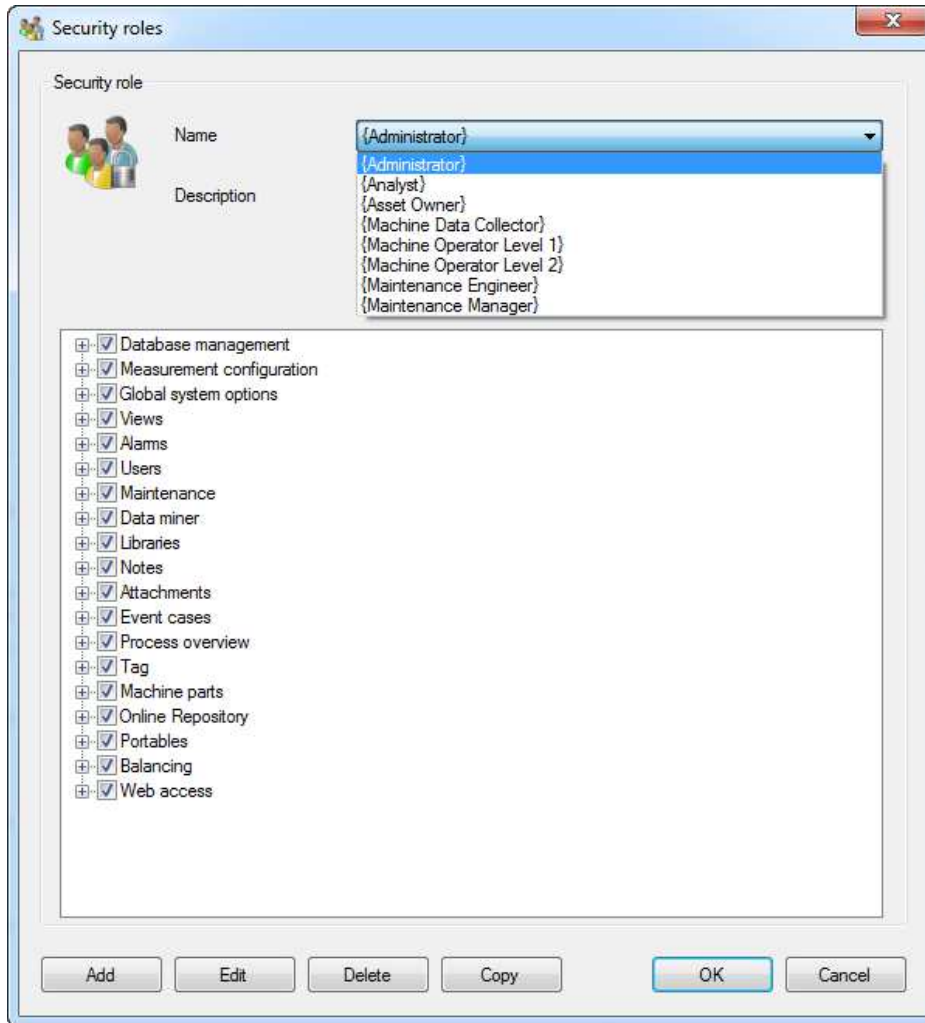

Figure 6 - 16.
Security Roles Dialog.

- Every user must be assigned to a security role to access the system. See [Configuring a User](#).
- Security roles that are marked with brackets are predefined in Observer and cannot be edited.

Some examples of predefined roles are shown below.

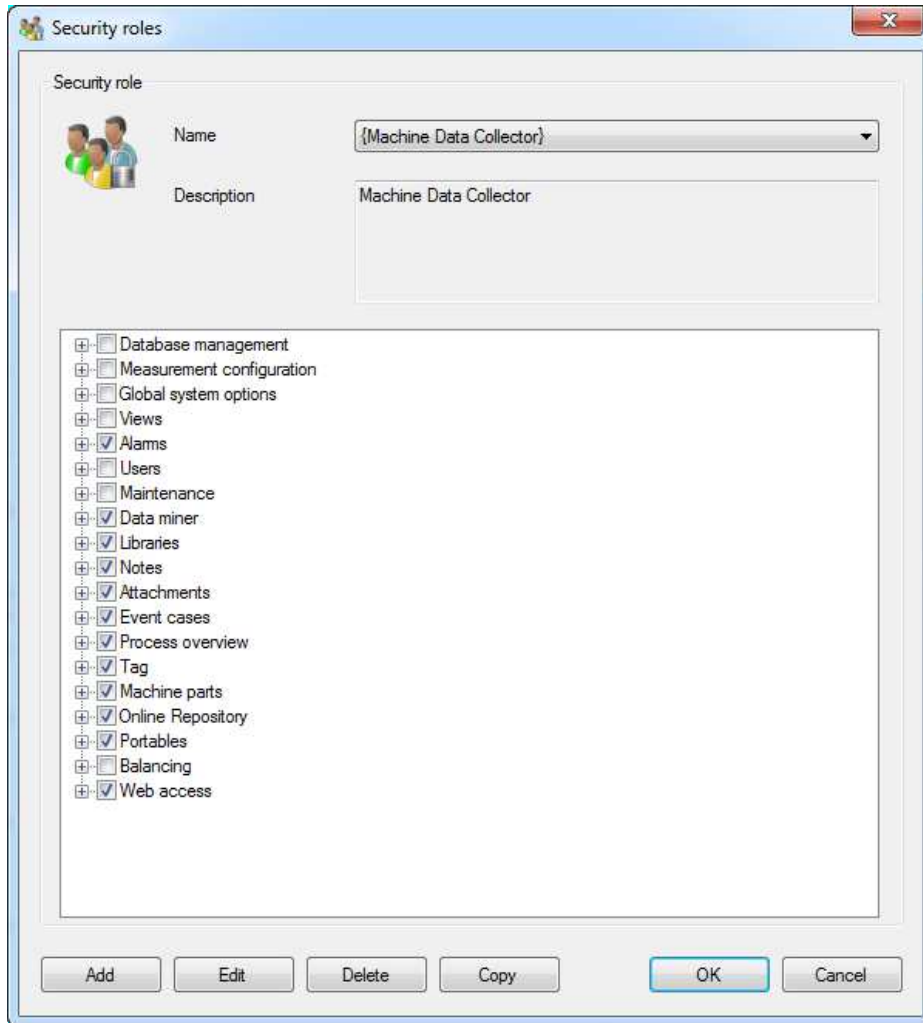

Figure 6 - 17.
Example of Machine Data Collector Security Role.

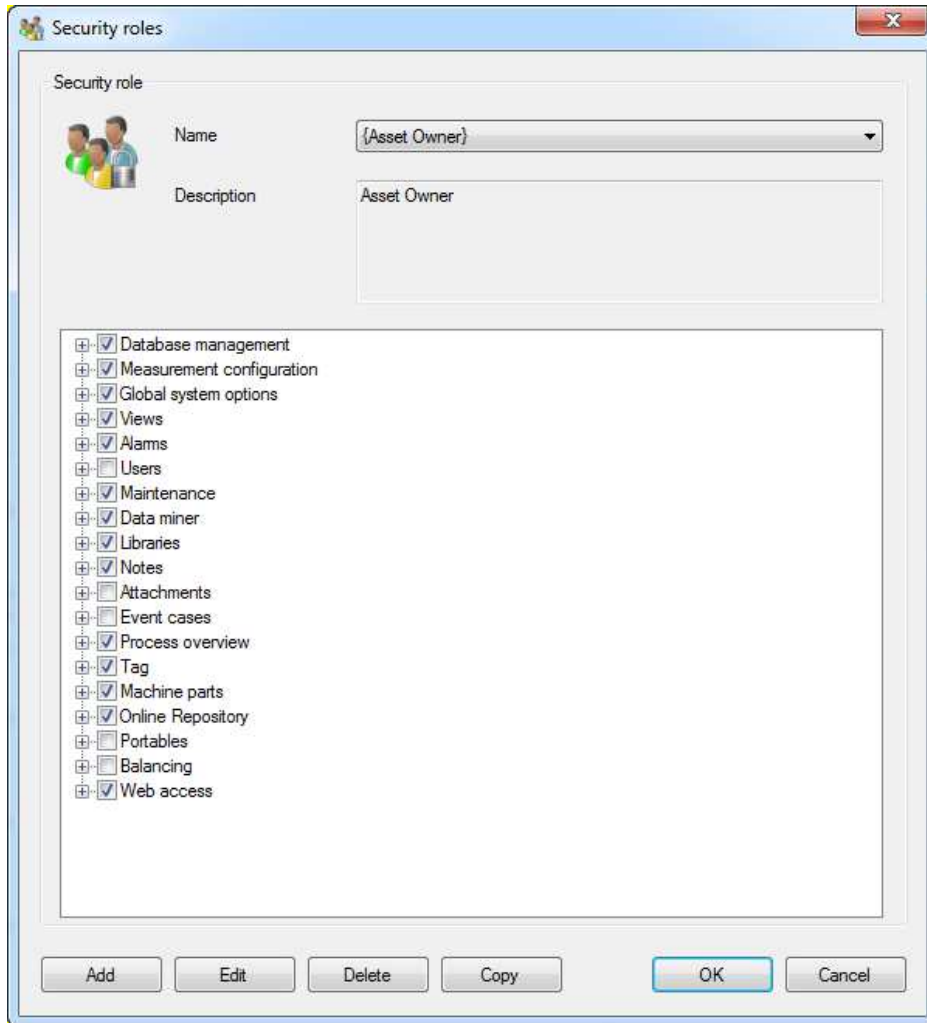

Figure 6 - 18.
Example of Asset Owner Security Role.

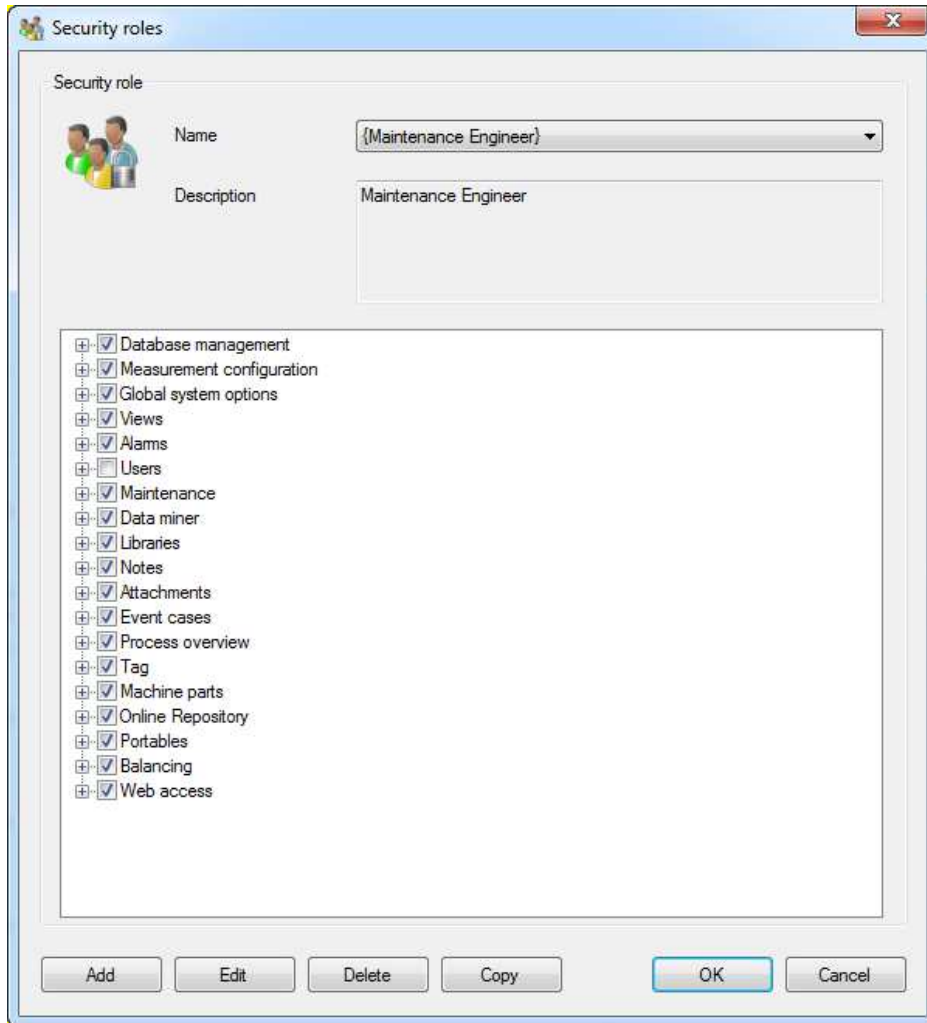

Figure 6 - 19.
Example of Maintenance Engineer Security Role.

Click **Add** to create a new security role.

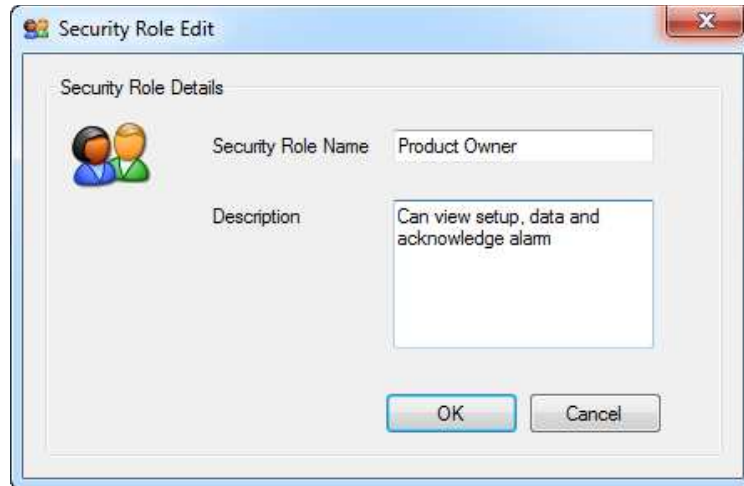

Figure 6 - 20.
Security Role Add/Edit Dialog.

Enter a **Security Role Name** and **Description**. Then, click **OK**.

It is possible to **Edit** customised roles and **Copy** existing roles.

A role can be deleted only if it is not assigned to any user. Attempting to delete a role assigned to a user displays a message, Figure 6 - 21.

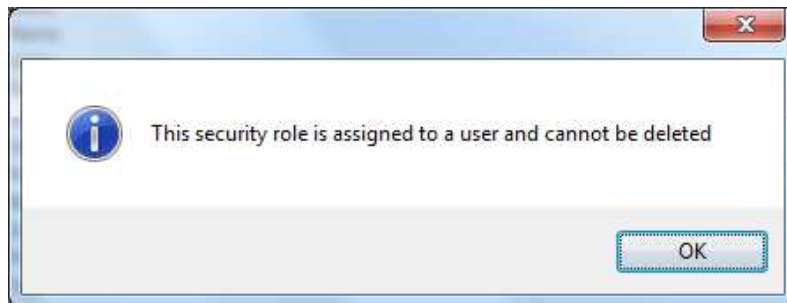

Figure 6 - 21.
Assigned Security Role Cannot Be Deleted Message.

Users

This interface brings up the Users window, Figure 6 – 22. This displays existing users and via **Session logs**, the session history for each user and which users are currently logged in. Those with rights to configure users, will also be able to add new users and edit or delete existing users.

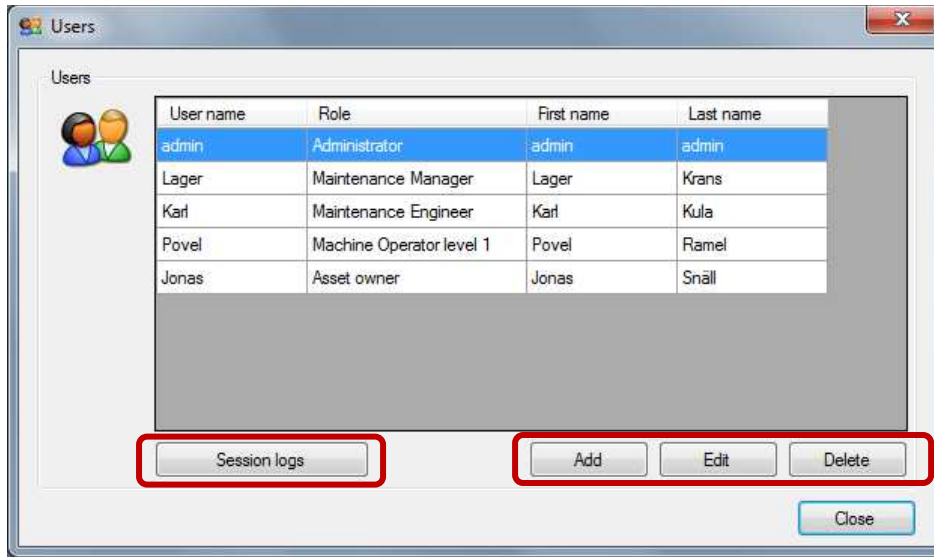

Figure 6 - 22.
Example of Users Dialog.

Viewing Session Logs and Current Users

Click the **Session logs** button to view the session history. This provides a quick overview of who was on the system and when.

- Only users of the default database are included; the users of external databases are not listed.

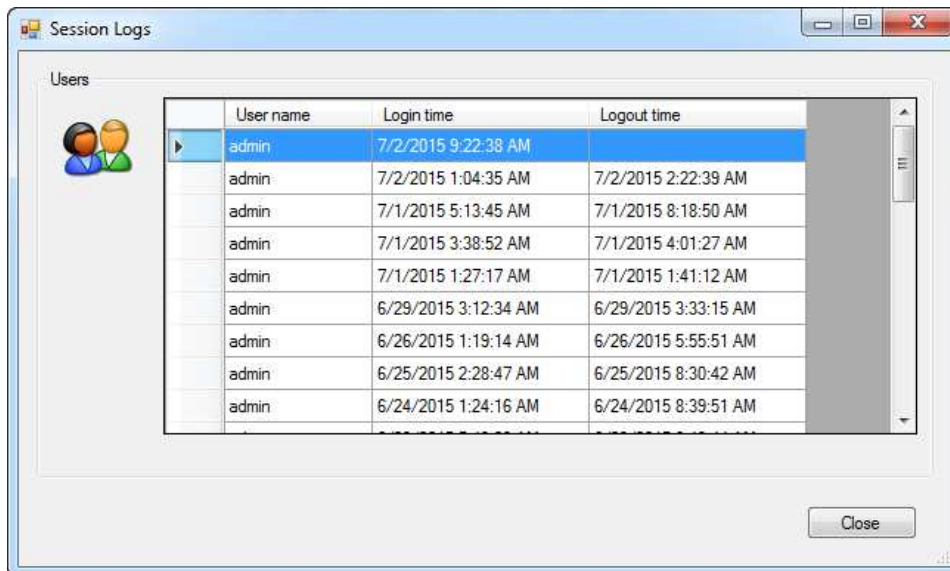

Figure 6 - 23.
Example of Session Logs Dialog.

The **Session Logs** dialog contains a read-only list of all the sessions (User name, Login time, Logout time, if any) for all users of the default database - even users who may have been deleted. It is sorted by **User name** (ascending) and **Login time** (descending). Note that if the **Logout time** is blank, then the user is considered to be logged in. If the user does not logout (via a session log out or

normally exiting the program, the Logout time will be blank. This will occur if the application closes abnormally.

To see a list of users who are currently logged into the default database, click **Current users** on the lower right portion of the tool strip bar.

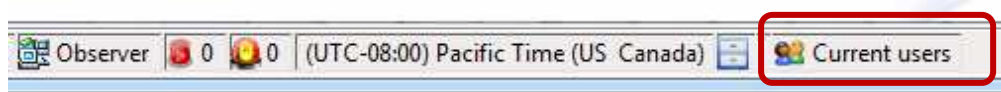

Figure 6 - 24.
Current Users on the Toolbar Strip.

The **Current users** dialog opens.

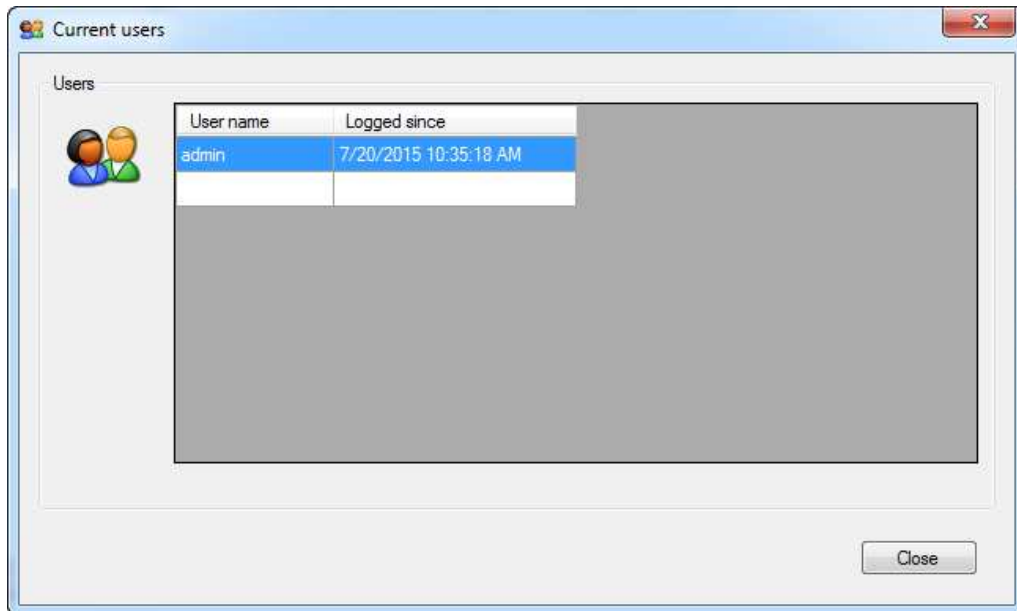
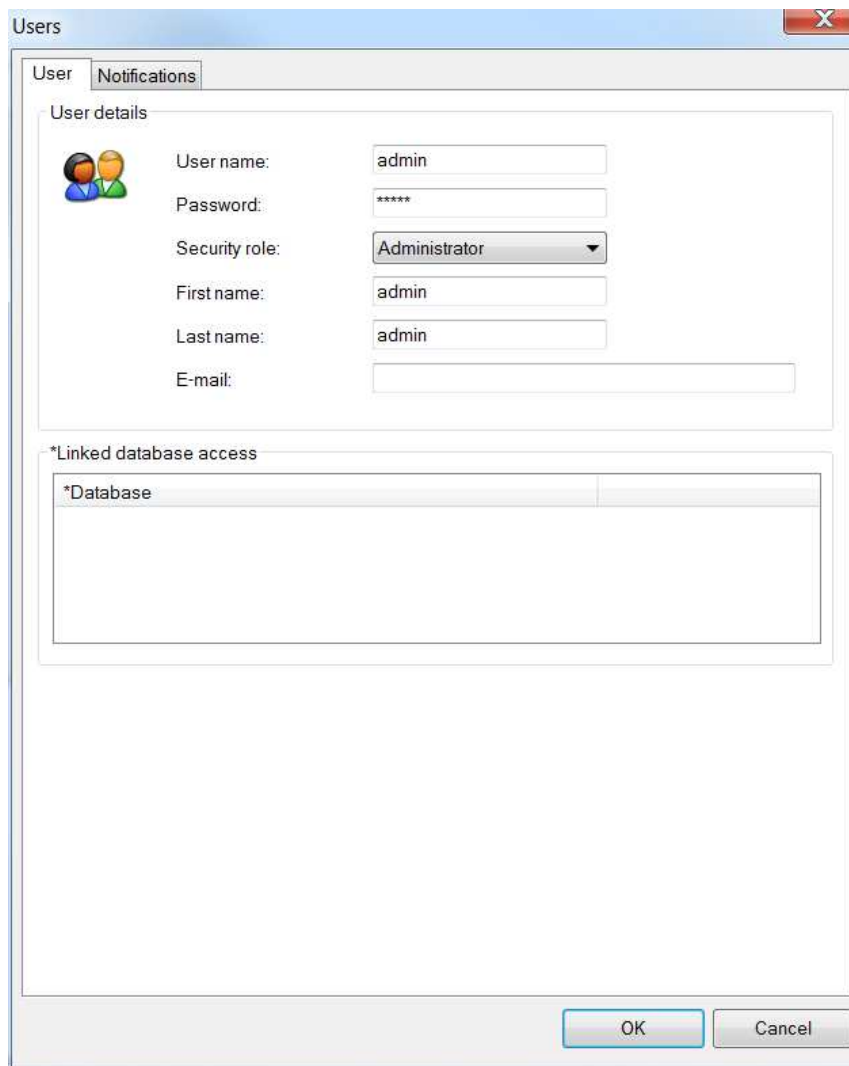

Figure 6 - 25.
Example of Current Users Dialog.

The **Current users** dialog displays a list of all the users who are currently logged in to the default database and when they logged in. This list can be used to help track who committed which changes. For example, if it is known that a specific action (such as, machine creation, data deletion) was taken at a certain time, this dialog could assist in determining which user initiated the action.

Configuring a User



The screenshot shows a window titled 'Users' with a close button in the top right corner. Inside the window, there are two tabs: 'User' (selected) and 'Notifications'. The 'User' tab contains a 'User details' section with a user icon and several input fields: 'User name' (admin), 'Password' (masked with asterisks), 'Security role' (Administrator), 'First name' (admin), 'Last name' (admin), and 'E-mail' (empty). Below this is a section for '*Linked database access' with a table header '*Database' and an empty table body. At the bottom right of the window are 'OK' and 'Cancel' buttons.

Figure 6 - 26.
Example of User Configuration.

User Details

User name is the login name of the user.

Password sets the password. User passwords are case sensitive.

Security role specifies the security role of the user.

First name is the user's real first name.

Last name is the user's real last name.

E-mail is the email address that will be used for notifications and/or status information selected.

Linked Database Access grants access to the selected database(s).

Notifications Tab

Send Alarm notifications lets the user receive periodic emails about alarms whenever alarms are available at a system configurable interval. The alarm report interval is set at E-mail settings tab within [Options](#) interface under [Database](#).

Send System alarm notifications lets the user receive periodic emails about system alarms whenever system alarms are available at a system configurable interval. The alarm report interval is set at E-mail settings tab within [Options](#) interface under [Database](#).

Send Monitor service status information lets the user receive periodic emails about the condition and status of the monitor service in addition to database condition. The status report interval is set at E-mail settings tab within [Options](#) interface under [Database](#).

Format offers three different types:

HTML can be used if the email provider supports displaying HTML emails.

Plain sends the email as plain text completely unformatted.

Truncated minimises the size of the email (it also contains less detail). This is especially useful if the emails are being forwarded to a mobile phone as SMS.

Use Custom Topic is a specific topic which will be used whenever the system delivers the selected notification(s) to the user. This is useful when a user has an email provider who offers a phone number recognition as the topic, for example "+46 070 XXXX XXXX". In such a case, if the user sets the Custom Topic to "+46 070 XXXX XXXX", the email notification(s) will be automatically forwarded to the specified number as SMS.

Database Information

Database information provides detail information on the SQL server database status.

To get to the database information screen:

- Click on **Database** on the toolbar, then select **Database information**.

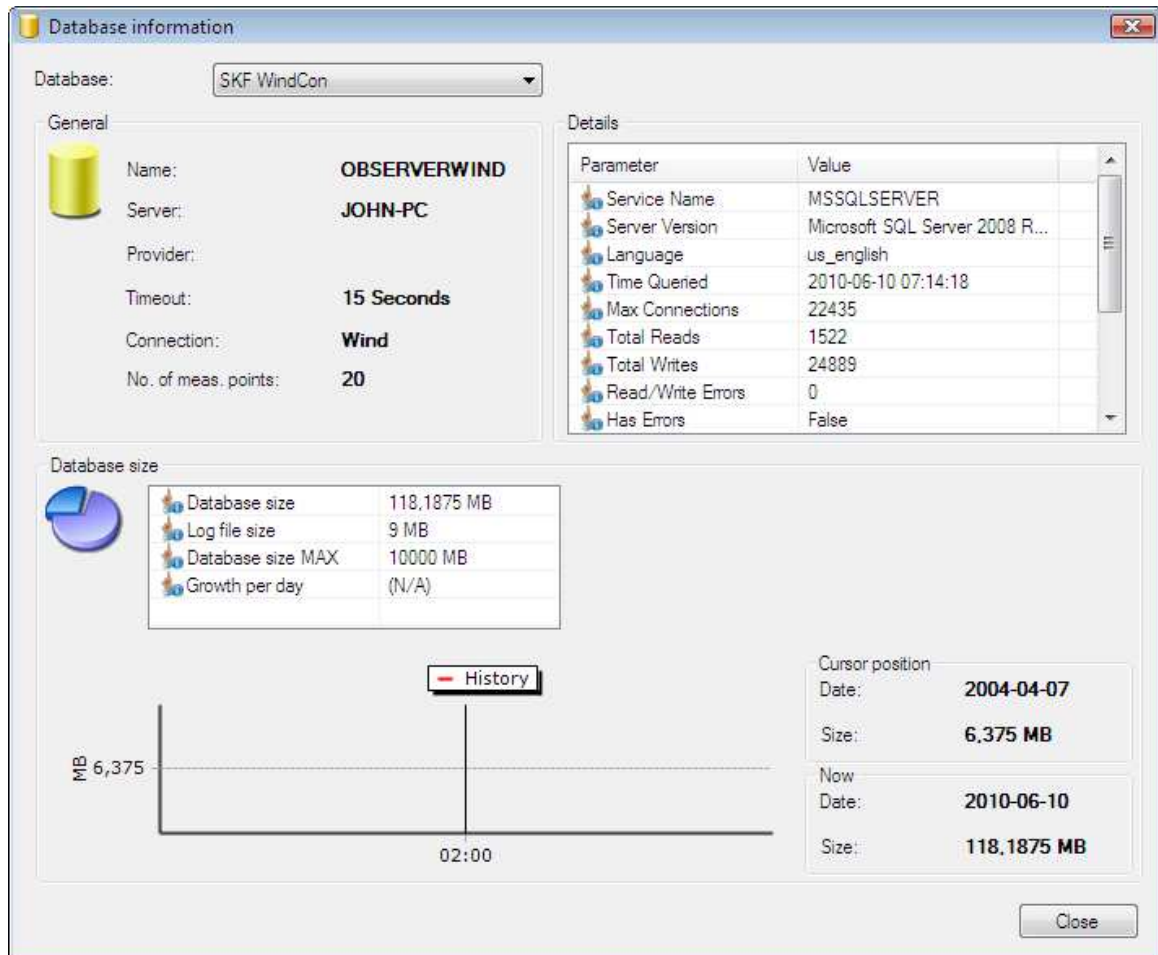

Figure 6 - 27.
Example of Database Information.

The database information displays the following:

- Current database situation of the selected database.
- Historical database growth trend with a predictive future trend if using on-line systems with @ptitude Observer Monitor.
- In-depth information about the SQL server operations.
- Memory information about the local computer.
- The total number of measurement points in the database.

System Log

The system log is a list of the configuration changes made to the system.

This includes all types of measurement points, channel information and hardware configuration of IMx/MasCon devices.

However, to see changes related only to a specific measurement point, channel or IMx/MasCon device, click on **System log** at the measurement point, channel edit or IMx/MasCon edit screens, respectively.

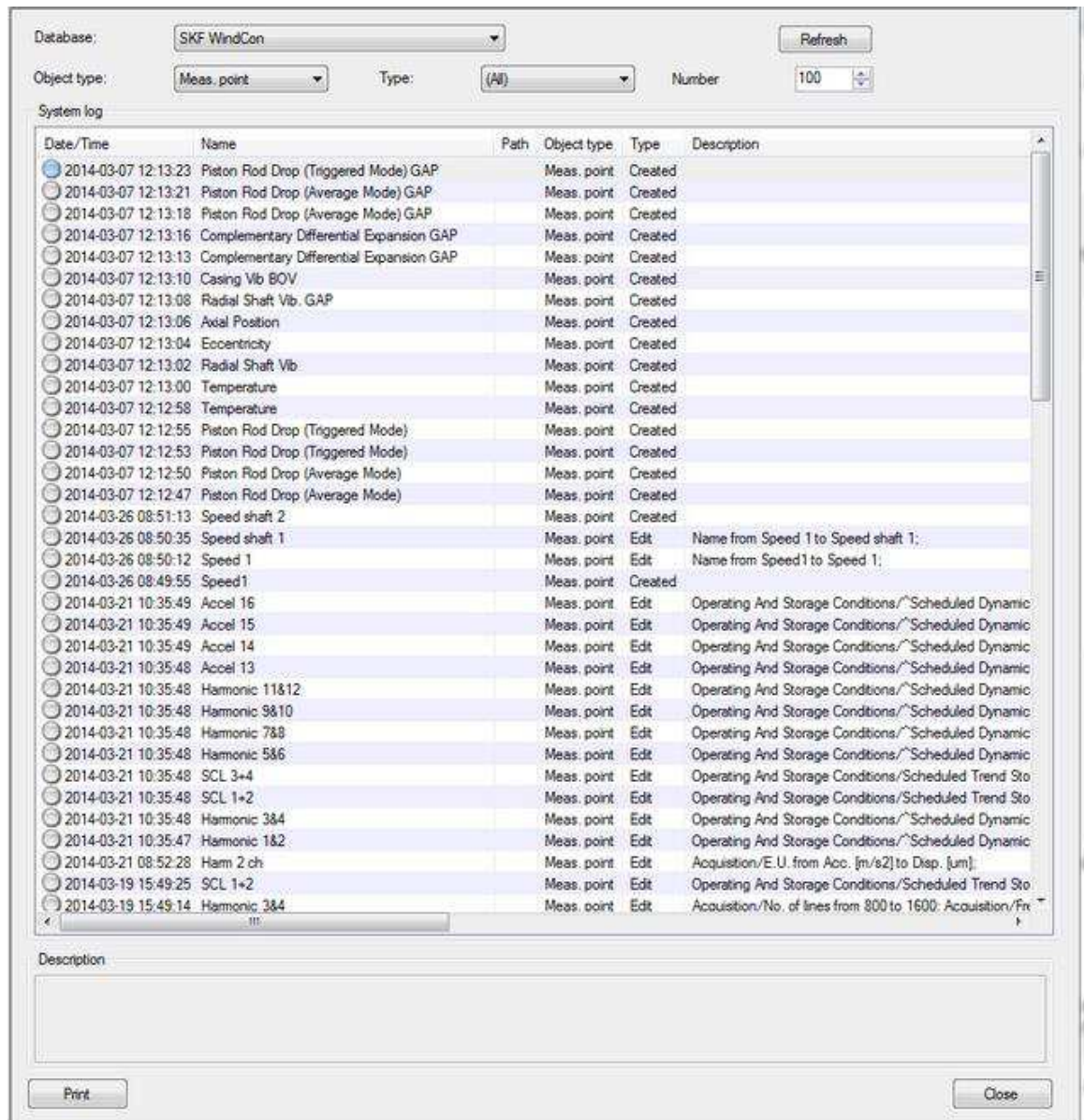

Figure 6 - 28.
Example of System Log.

The list can be filtered and grouped by database, object type and type.

Pictures

Pictures interface provides the capability to manage the pictures stored in the database. Pictures can then be used to support notes, provide process overview and graph display backgrounds.

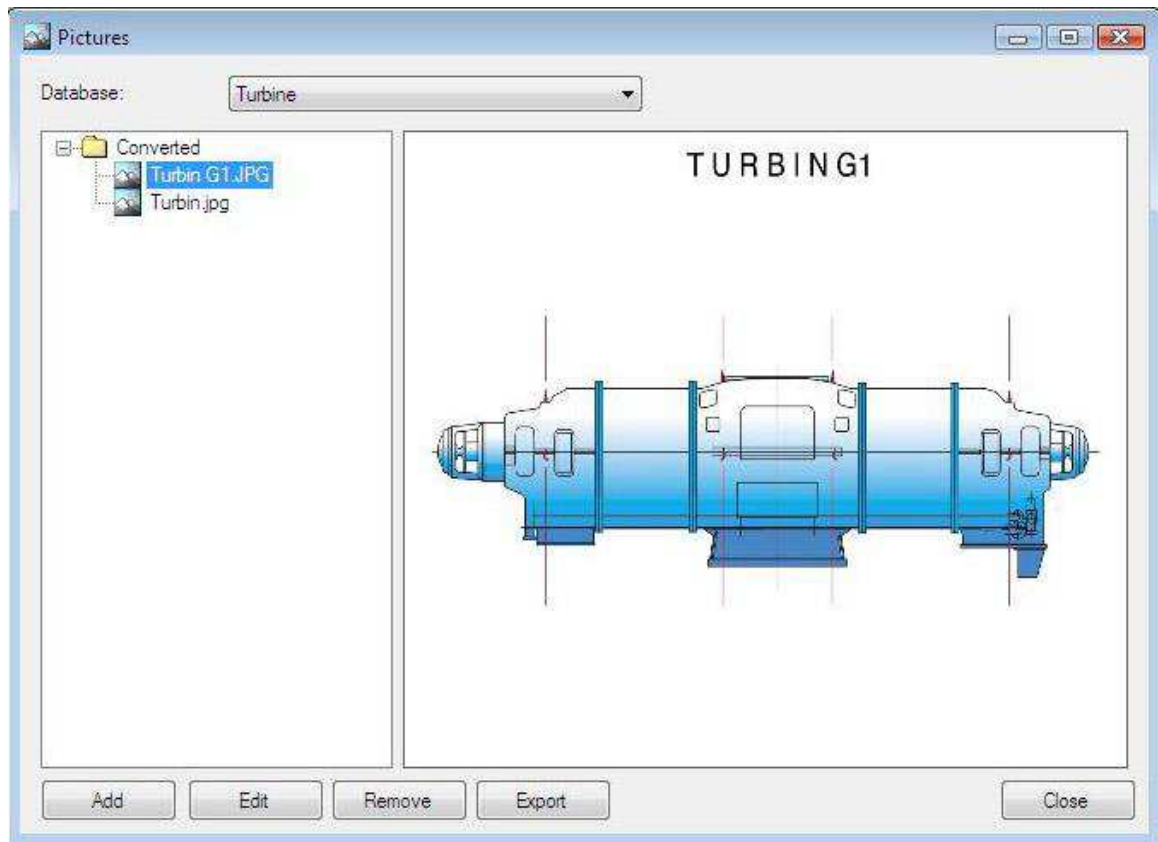

Figure 6 - 29.
Example of Pictures Interface.

Database is where the pictures reside.

Add allows adding pictures to the database to be used for display purposes.

Edit replaces the current picture by another one.

Remove allows removing the selected picture from the database.

Export allows exporting the selected picture to a selected path. It can be used to transfer pictures between databases.

Diagnoses

Adding Diagnoses to a Machine

The diagnostics can distinguish between data captured in the different Operating Classes. When attaching a diagnosis, there is a choice as to whether the diagnosis will use data captured in the different Operating Classes. This option is always editable, without regard to the particular diagnosis being a private diagnosis or not.

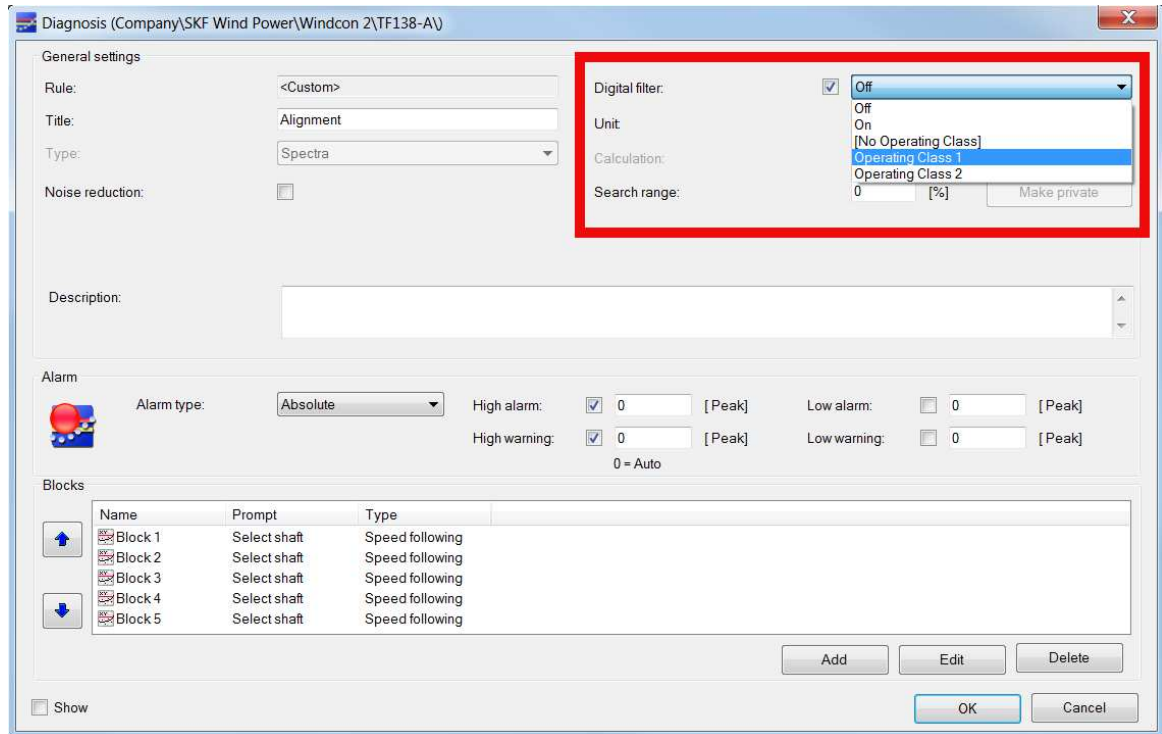

Figure 6 - 30.
Example of Diagnosis Dialog.

Select the **Digital filter** checkbox to enable the function. Then select the type of data to capture for the alarm:

Off (digital): operate in all conditions

On (digital): used with digital points, value true

No Operating Class: ignore the operating classes; use with multiple gating point (MGP)

Operating Class 1 [customised name]: use operating class 1 data only; use with multiple gating point (MGP)

Operating Class 2 [customised name]: use operating class 2 data only; use with multiple gating point (MGP)

The automatic alarms for the diagnosis will be calculated only in the specified operating class or digital state and will alarm only on the alarms in the specific class.

Diagnosis Rules

When viewing a frequency spectrum, it can be a difficult task to find out which machine part causes the particular frequency. To make this analysis easier, there are ready-made formulas which link frequencies and harmonics together with the correct machine part and correct cause of error. These formulas are called

diagnosis in @ptitude Observer and are an excellent tool to use as they allow the system to automatically and intelligently diagnose machine and machine parts for possible fault modes.

The machine diagnostics are built from a specific set of rules called **diagnostic rules**. There are two types of diagnostic rules, those defined by SKF are called **Standard diagnostic rules** and those defined by the user are called **Custom Diagnosis rules**.

To select which diagnosis rule to attach to a specific machine, refer to [Machine Properties](#).

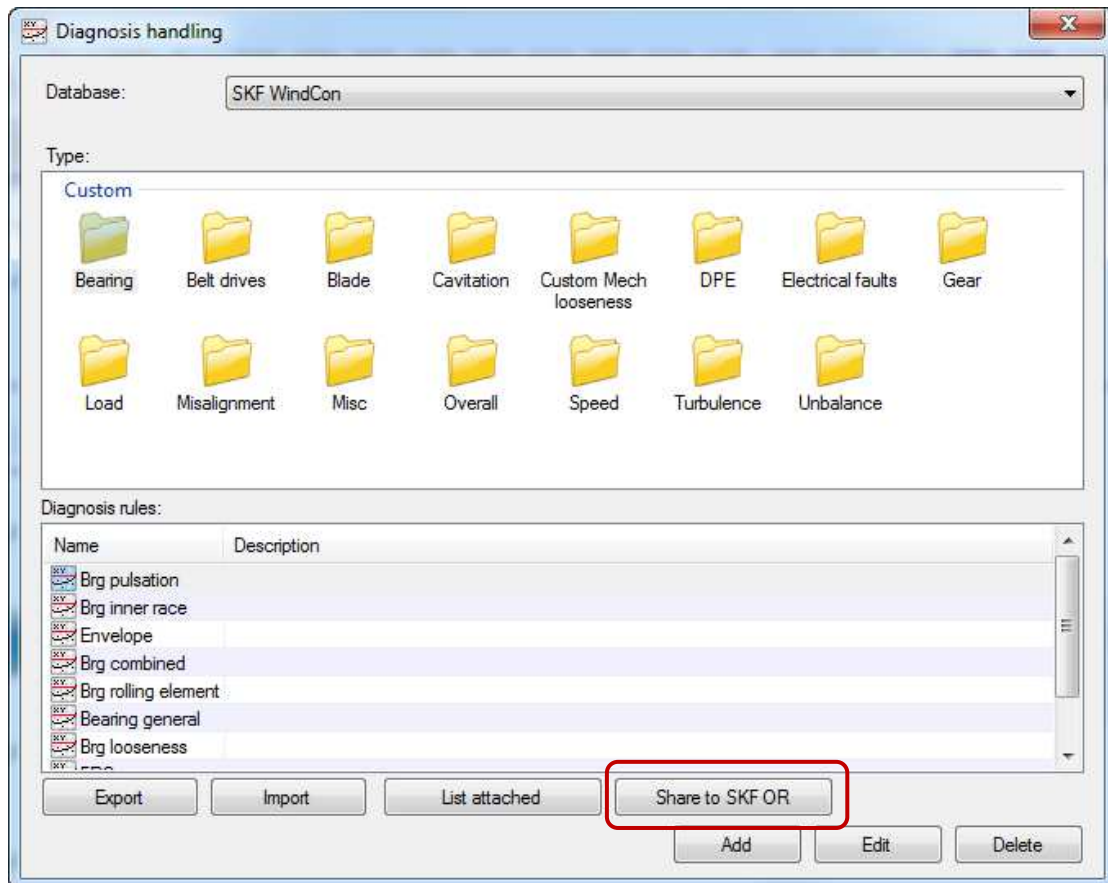

Figure 6 - 31.
Example of Diagnosis Handling Screen.

Export saves the selected diagnosis to a local file.

Import imports a previously exported diagnostic rule.

List attached displays a list of any attached diagnosis in the system built from the selected diagnostic rule.

Share to SKF OR is for sharing the selected diagnosis rule with SKF Online Repository Users. Only custom diagnosis rules can be shared.

Add / Edit / Delete provides access to create / change configuration / delete a diagnosis with user defined rules.

Creating a custom rule

The screenshot shows a dialog box titled "Diagnosis rules" with a close button (X) in the top right corner. The dialog is divided into three main sections: "General settings", "Alarm", and "Blocks".

General settings:

- Diagnosis type: Bearing (dropdown)
- Name: Bearing 1 (text field)
- Title: (empty text field)
- Source: Spectra (dropdown)
- Source input unit: m/s2 (dropdown)
- Calculation: Rms (dropdown)
- Noise reduction: (checkbox)
- Search range: 2 [%] (text field)
- Description: (empty text area)

Alarm:

- Alarm type: Relative (dropdown)
- High alarm: 150 [%] (checkbox and text field)
- Low alarm: 80 [%] (checkbox and text field)
- High warning: 150 [%] (checkbox and text field)
- Low warning: 80 [%] (checkbox and text field)
- 0 = Auto (text)

Blocks:

Name	Prompt	Type
Bearing	Select Bearing	Speed following

Buttons: Add, Edit, Delete, OK, Cancel

Figure 6 - 32.
Example of Creating Custom Diagnostic Rule.

Diagnosis type is the categorisation type of this rule.

Name is a user defined name to use for this rule.

Title is displayed for all measurement points that implement this particular diagnosis.

Source Input Unit defines the unit in which this diagnosis should be trended.

Type selects a type of data upon which the calculation is based.

Calculation:

Rms calculates the Rms value for the selected frequencies.

Sum calculates the sum of the selected frequencies.

% of Overall calculates the Rms of the selected frequencies and divides it by the overall.

Peaks counts the number of peaks in the selected frequencies.

Frequency finder finds the highest peak and trends its frequency.

% band overall takes the value calculated from Blocks (described below) and divides it by the value calculated for the selected band, showing the result in percent. The **Alarm type** may be either Absolute or Relative.

% speed following band takes the Block calculation result and divides it by the calculated value to get the relative percentage value. The **Alarm type** must be Absolute.

Frequency range for the calculation must also be set when using % band overall or % speed following band. For % speed following band, the frequency range is entered as a multiple of the speed.

RMS/RSS specifies the calculation type to use with % band overall or % speed following band. All added Blocks are calculated using either the selected RMS (root mean squared) or RSS (root sum squared) method. Both methods use the same Rms formula, but the RMS method uses one spectrum line for the peaks in the Block, where the RSS method calculates peaks with spectra lines line -1 to line +1 around the peak so that three spectra lines are used.

Diagnosis rules

General settings

Diagnosis type: Overall

Name: Diag rule name

Title: Diag rule title

Source: Spectra

Source input unit: mm/s

Calculation: % band

Frequency range Start: 0 [%] End: 0 [%]

RMS/RSS: Rms

Noise reduction: Search range: 2 [%]

Description:

Alarm

Alarm type: Absolute

High alarm: 0 [%] Low alarm: 0 [%]

High warning: 0 [%] Low warning: 0 [%]

0 = Auto

Blocks

Name	Prompt	Type
Block 1	Block 1	Fixed frequency range

Add Edit Delete

OK Cancel

Figure 6 - 33.
Diagnostic Rule Setup for % Band.

Diagnosis rules

General settings

Diagnosis type: Overall

Name: RMS Speed following band

Title: RMS Speed following band

Source: Spectra

Source input unit: mm/s

Calculation: % speed following band

Frequency multiple Start: 1 [X] End: 10 [X]

RMS/RSS: Rms

Noise reduction: Search range: 2 [%]

Description:

Alarm

Alarm type: Absolute

High alarm: 0 [%] Low alarm: 0 [%]

High warning: 0 [%] Low warning: 0 [%]

0 = Auto

Blocks

Name	Prompt	Type

Add Edit Delete

OK Cancel

Figure 6 - 34.
Diagnostic Rule Setup for % Speed Following Band.

Noise reduction applies a filter that removes the noise from the spectra before the calculation begins, if checked.

Search range performs a search for maximum amplitudes within this range.

Description briefly describes the diagnosis. It is recommended but not mandatory when creating customised diagnosis rules.

Alarm type sets the alarm for the diagnosis.

Absolute means that the alarm values are set in engineering units.

Relative means that the alarm levels are set in percent of a baseline level. The baseline level is calculated based on a number of historical values.

Alarm/Warning sets the default alarm/warning levels. Setting the alarm/warning levels to zero enables automatic alarm/warning settings and @ptitude Observer will adjust the alarm/warning levels when new data arrives. After five measurements have been taken, @ptitude Observer will save the alarm/warning levels.

Blocks are different types of frequencies used in the calculation. Use the arrow buttons on the left side to rearrange the order of the blocks. Blocks can be added, edited or deleted.

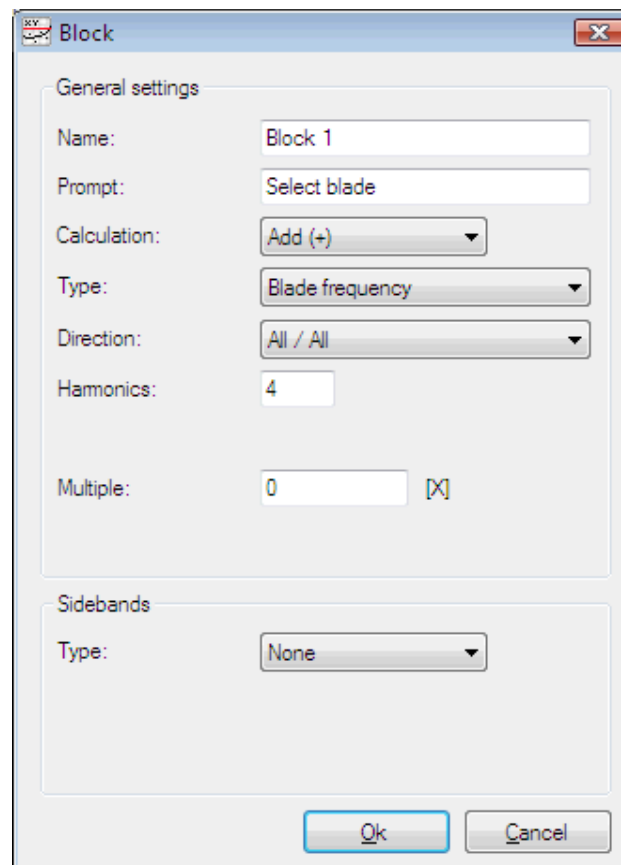

Figure 6 - 35.
Example of Diagnosis Block Settings.

Name is the name of the block.

Prompt is what to ask the user when attaching the diagnosis. If prompt is the same on the other blocks the user will only be asked once.

Calculation can add and subtract frequencies from the calculation or zero out by setting the amplitude for the selected frequency to zero.

Type is the type of (or which) frequency to use. Based on the selection made, different parameters appear.

Direction specifies in which direction the data should be calculated.

Harmonics specifies the number of harmonics that should be included in the calculation.

Multiple is the number to multiply the frequency. Default is 1.

Frequency specifies the frequency in cpm (cycle per minute) that should be monitored.

Sidebands Type selects the sidebands type.

List Diagnoses That Need Attention

This interface lists all attached diagnoses that are incorrectly configured for the entire database. There are a few reasons why this could happen and one of the most common reasons is that a machine part that a specific diagnostic is using for its calculation, has been deleted or removed from the machine. The system does not know how to calculate the diagnostics and now it is flagged as a diagnosis that needs attention by the user. Click on the edit button to reconfigure any diagnosis that needs attention.

Libraries

Libraries interface has the following functions available.

- [Bearing library](#)
- [Report library](#)
- [Receivers](#)
- [Tag library](#)
- [Data tagging group](#)
- [Machine template library](#)
- [Create machine template](#)

Bearing Library

Bearing library manages an @ptitude Observer bearing database and allows access to the information held on any of the listed bearings. When building machine parts, the system only allows for the selection of a bearing available within a database. However, user defined bearings can be added to the system.

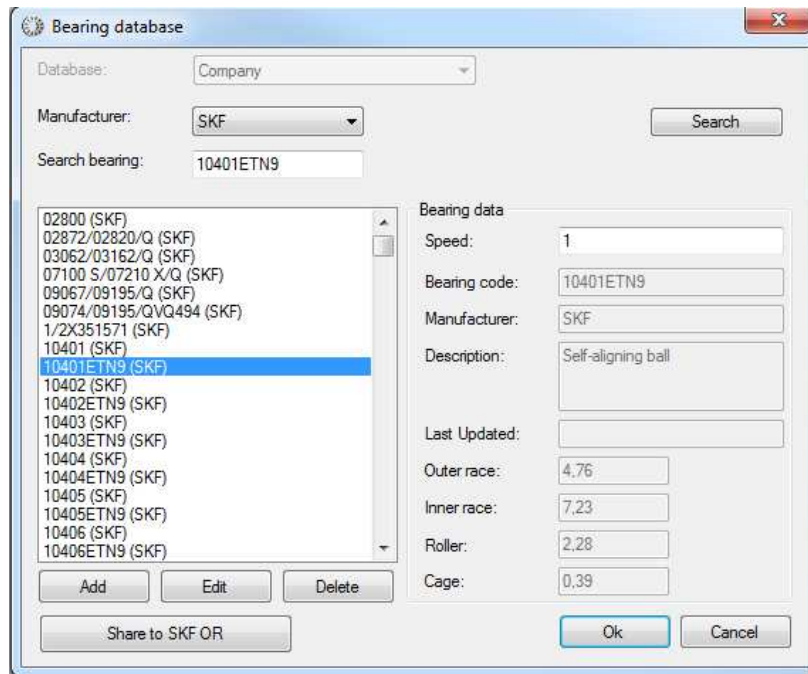

Figure 6 - 36.
Example of Bearing Library.

All bearing databases contain data for the bearings used in diagnosis and frequency calculations in @ptitude Observer. This makes it easy to identify and detect bearing defects and damage. As part of the descriptive data, 'Last Updated' information is available. Note, as shown above, this field will be blank when no new date is available for a specific bearing in the database.

Report Library

The report library contains standard layouts for event case reports. New layouts for event case reporting can be added and existing layouts can be edited or deleted.

New layouts for use in the event case reporting interface are designed with crystal reports software: this is available for purchase at many software vendors.

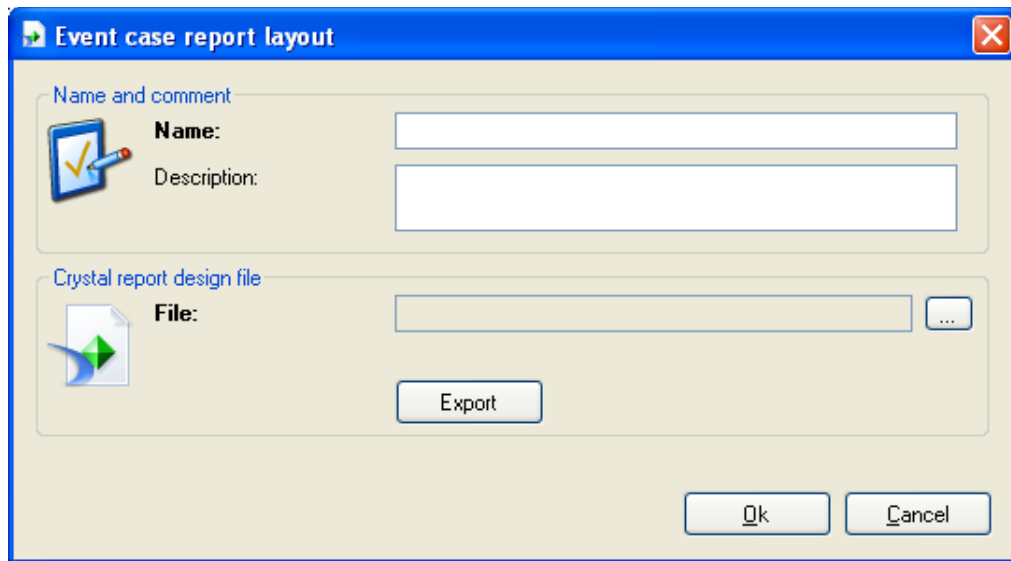

Figure 6 - 37.
Example of Event Case Report Layout.

Name for the layout.

Description for the layout.

File is the crystal report design file (.rpt) to use for the layout.

Receivers

Receivers interface is used to create, edit or delete a group of receivers for the selected database. This group is used when selecting a receiver for notes. Refer to [Notes](#) in System Operation. By naming each group meaningfully, it can support the effective distribution of notes.

Tag Library

In Observer it is possible to “tag” measurement points or machines with specific customised tags. These tags are configured in the tag library. There can be several tags configured in the library, ranging from A to Z. When configuring a tag, a letter (A to Z) that should be used as a graphical identifier of the icon and the colour of the icon, can be chosen.

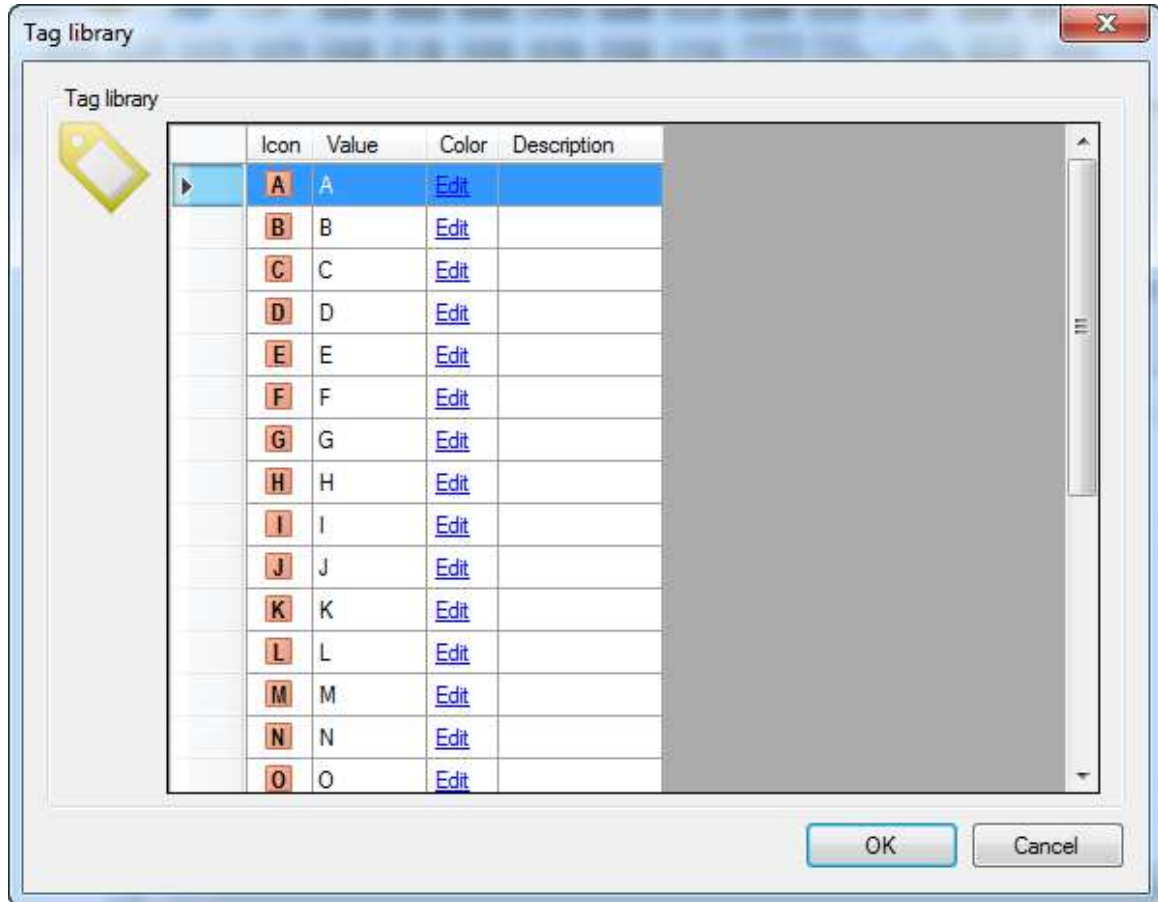

Figure 6 - 38.
Example of Tag Library.

Set the colour of the icon by clicking on the edit text in the 'Color' column. Set the description of the tag by clicking in the description column and entering the description of the tag.

Once a tag has been created in the library, the tag can be used to tag measurement points or machines. Tagged measurement points and machines will be marked with a tag after the name of the node as illustrated in Figure 6 – 39, below.

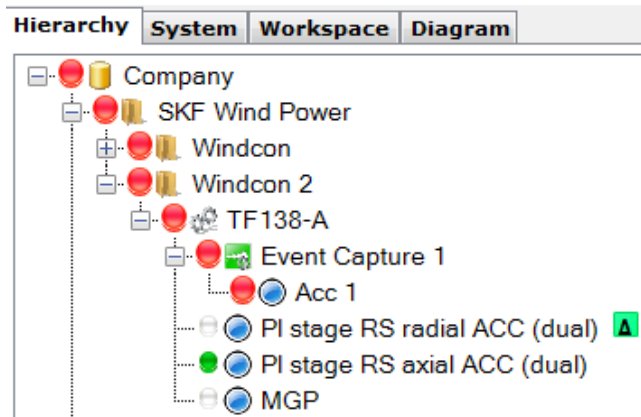

Figure 6 - 39.
Example of Hierarchy View with a Tag.

To tag a specific measurement point or machine, open properties and click the inactive tag icon.

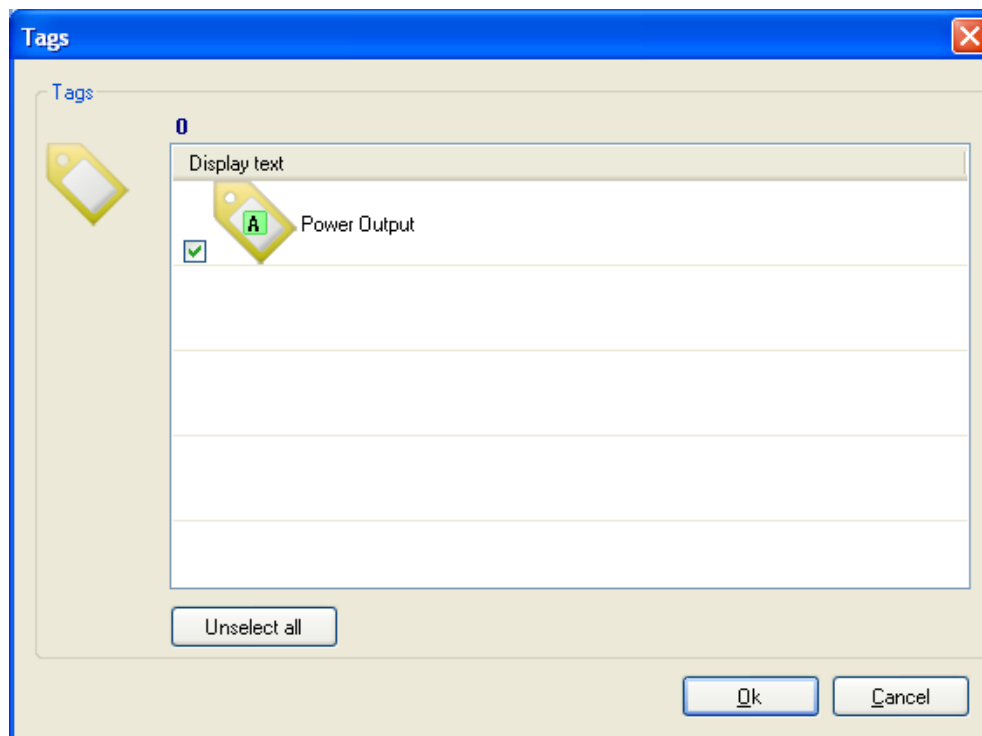

Figure 6 - 40.
Example of Setting a Tag.

Select a tag to set it on the selected measurement point or a machine.

Data Tagging Group

Allows a user to create, edit or delete a data tagging group. Note that to be able to create a data tagging measurement point, there must be an existing data tagging group.

Machine Template Library

It displays machine templates and performs the following actions:

Delete deletes a template from the machine template library.

Export exports a machine template to a file with the file extension of .omt.

Import imports a machine template from a file into the machine template library.

Create Machine Template

A machine template can be created based on a selected machine from the hierarchy view. It will then reside in the machine template library.

Note that to create a machine template, the (source) machine must be configured with all the properties and measurement points.

Export

Export interface exports structure/data from the database. Export files are stored as .xme for hierarchy elements and .xmd for measuring data.

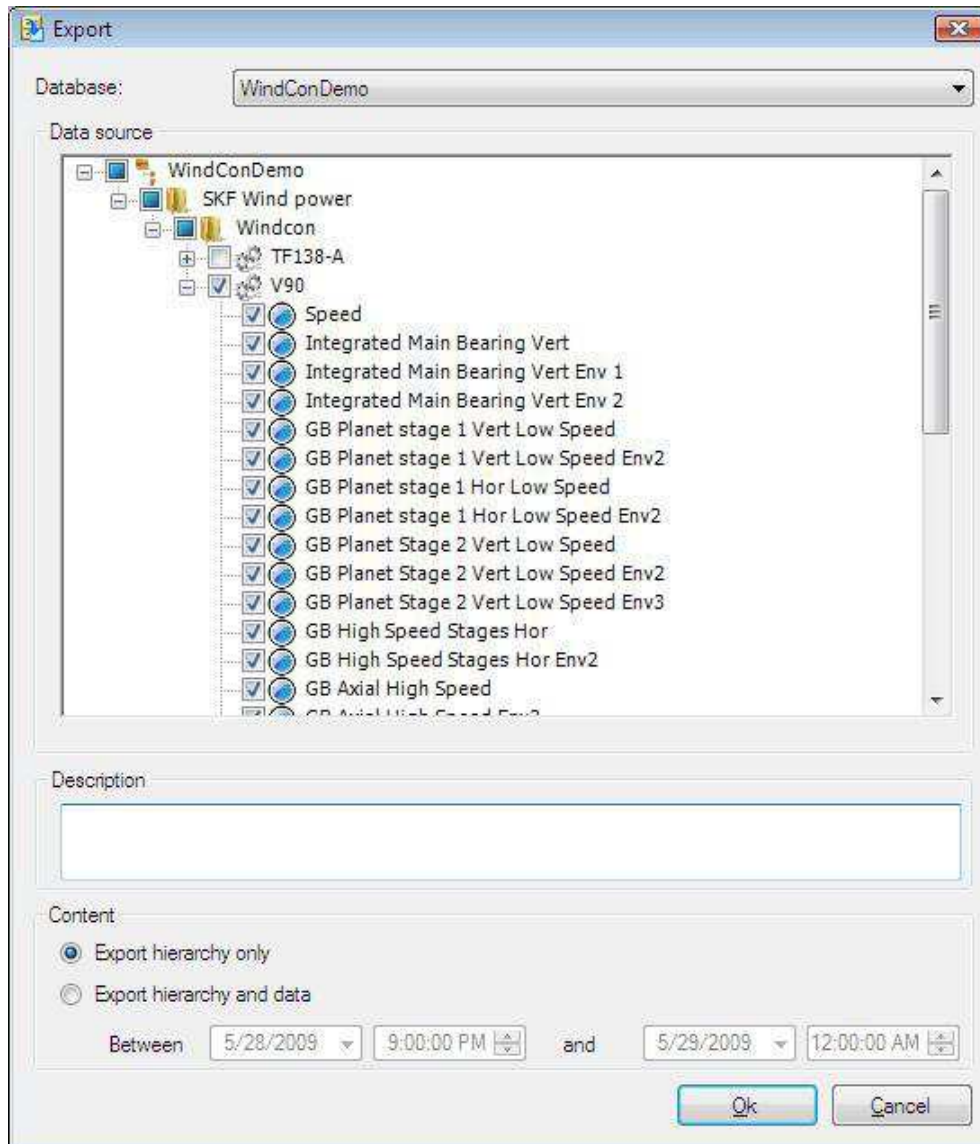

Figure 6 - 41.
Example of Export Structure/Data.

Database is where the structure/data to be exported, resides.

Data source is the node(s) that should be included in the export process.

Description is a custom description about the export file which will be displayed to the user when importing the data.

Content is the export content which can be only the structure of the hierarchy or the structure of the hierarchy along with measurement data from the specified date and time.

Import

The Import interface enables the importing of .xme and .xmd export files generated by @ptitude Observer.

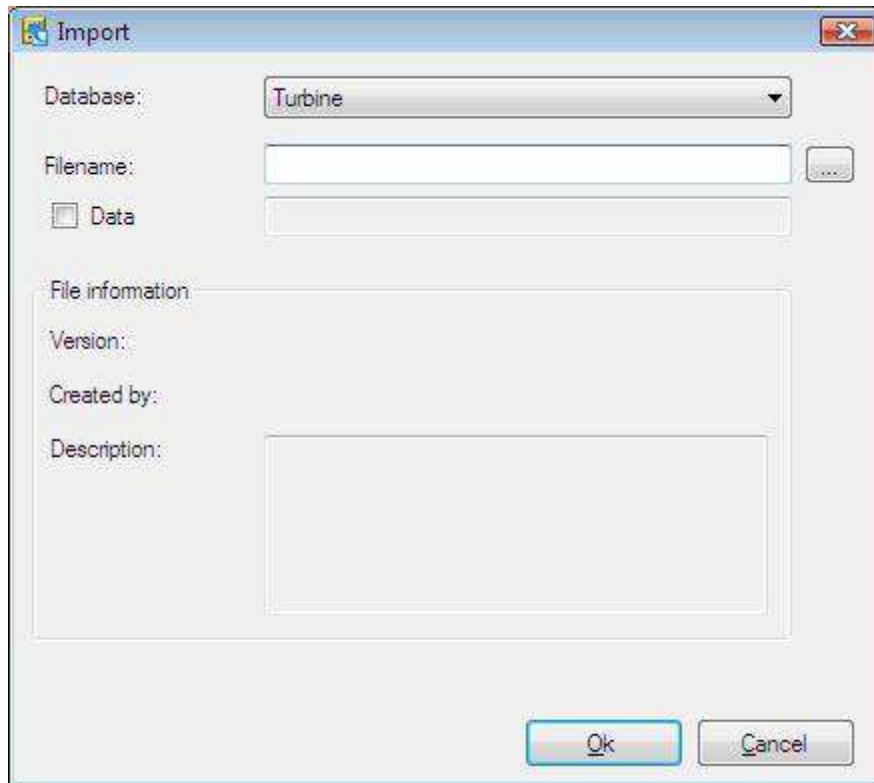

Figure 6 - 42.
Example of Import Data.

Filename can be selected from the drop-down list of all @ptitude Observer export files (*.xme and *.xmd). If the measurement data should be imported as well, then mark **Data**. If a machine included in the import file has been imported before, the system automatically merges the data into the existing hierarchy.

Important - The export and import interfaces should be used only to export or import minor parts of the database in order to get the same measurement hierarchy as in other database or to send small pieces of data for someone external to analyse them. It should not be used under any circumstances, to transfer data between databases.

Alarm Group

Alarm group is used as an identifier for measurements that have a strong relationship towards one another. For example, when creating an alarm group with six measurement points, then any alarm on any one of the six measurement points can force the storage of data for all six measurement points of the alarm group.

Figure 6 – 43 below, shows an alarm group and the measurement points belonging to that group.

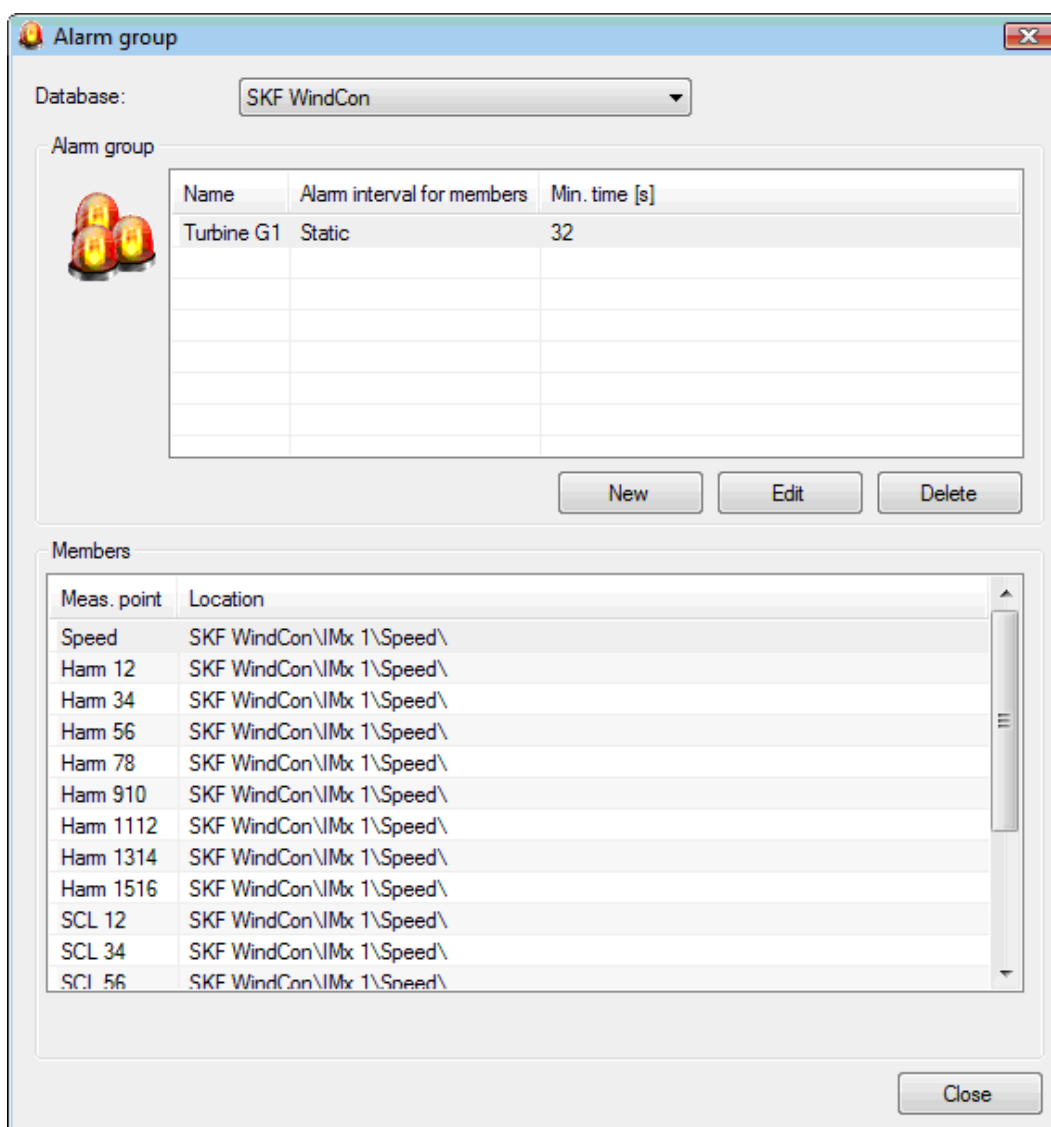

Figure 6 - 43.
Example of Alarm Group.

A new alarm group can be created and an existing alarm group can be edited or deleted. A new measurement point can be added to the selected alarm group or an existing measurement point, removed from the group.

Creating a New / Editing an Alarm Group

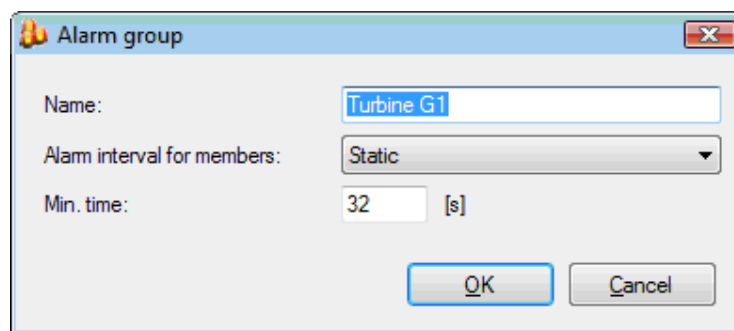

Figure 6 - 44.
Example of Alarm Group – Edit.

Name is the name of the Alarm group to be created or edited.

Alarm interval for members enables the selection of a scheduled storage setting (configured by [Operating and Storage Conditions Tab](#) under Setting up Measurement Points and Alarms in System Configuration).

None uses the normal scheduled storage setting on other measurement points.

Static uses the alarm scheduled storage setting on all measurement points in the group to store static values with alarm intervals.

Static and Dynamic uses the alarm scheduled storage setting on all measurement points in the group to store static and dynamic values with alarm intervals.

Min. time is the duration of time in seconds that must pass without any alarm in order to store all measurement points' data of the specified alarm group. The recommended minimum time is 30 seconds.

Measurement Groups

A measurement group is a logical grouping of measurement points that will collect a specific type of data for a particular purpose; for example, at the same time and synchronously on a specific IMx/MasCon device.

Three types of measurement groups can be created: simultaneous, transient and event capture. Note that the type and frequency type of the measurement group cannot be changed after the group has been created.

Note: The maximum number of active measurement groups per IMx is five, including transients (T), simultaneous (S) and event capture (E) groups. The limit for event capture groups per IMx is one. For example, the maximum of five groups may consist of: 1E+2T+2S or 1E+4T or 5T or 5S, etc.). If an event capture group is active in the database, then the pre-and post-data function of any existing transient group cannot be used.

Go to **Database > Measurement groups** to open the dialog.

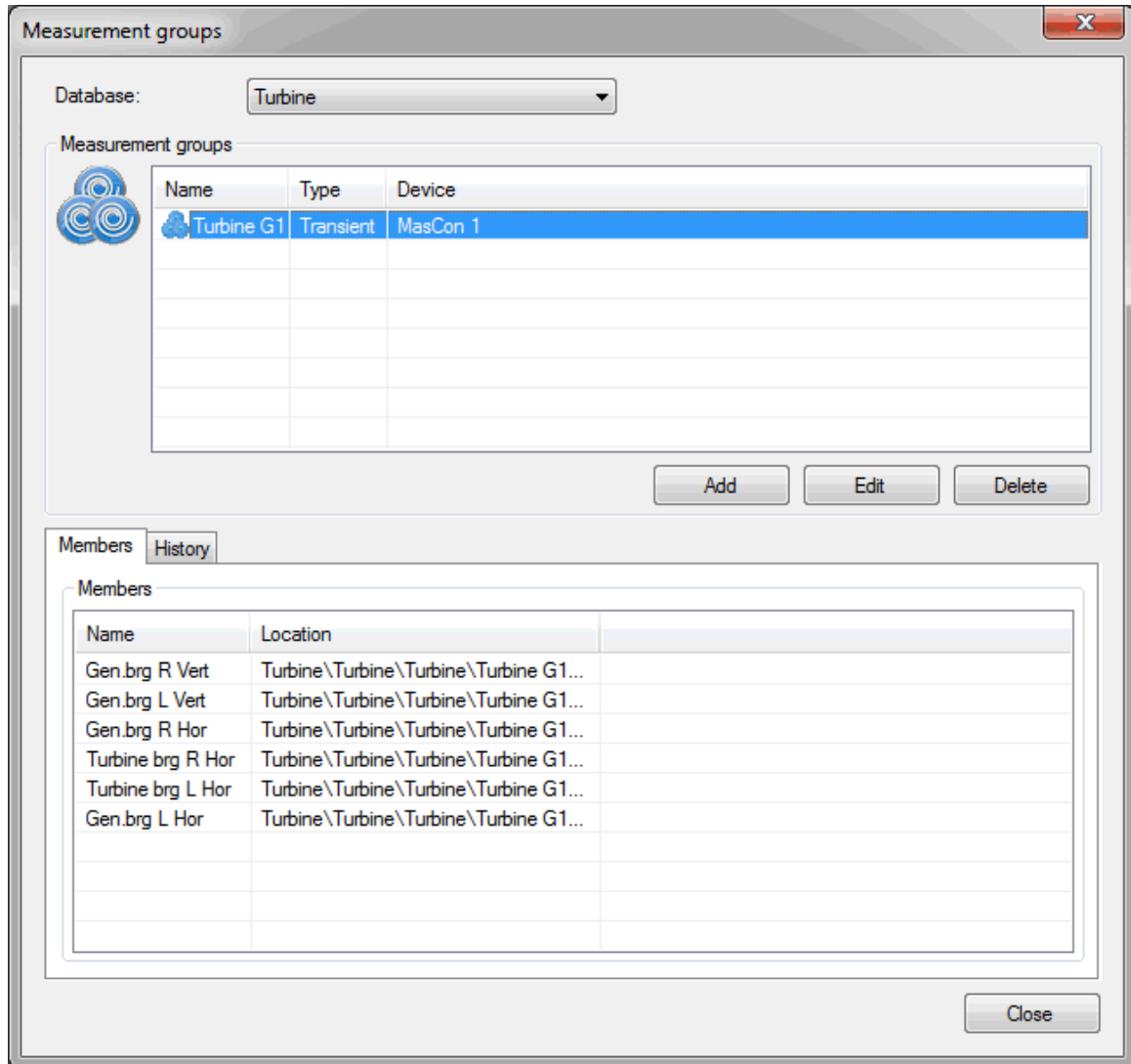

Figure 6 - 45.
Example of Measurement Groups Dialog with a Transient Group.

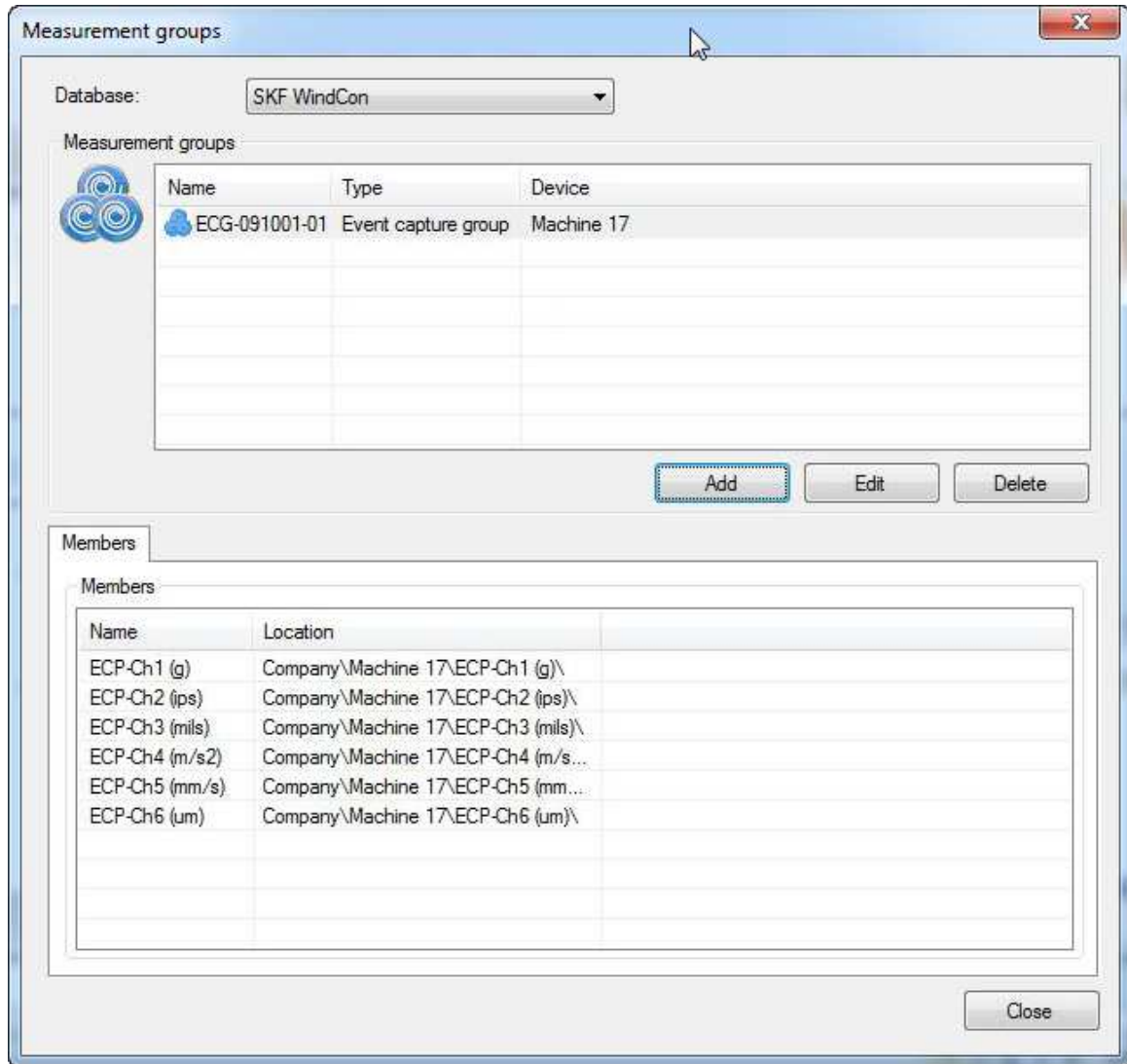

Figure 6 - 46.
Example of Measurement Groups Dialog with an Event Capture Group.

Measurement groups in the selected **Database** are listed. **Type** indicates the measurement group type and **Device** shows the data acquisition device (DAD) specified for the measurement group.

Members tab is a list of the measurement points assigned to the highlighted measurement group.

History tab is a list of the historical run-ups and coast-downs currently stored in the database for a transient measurement group. They can be edited, deleted or set as a reference transient. The list shows the **From** and **To** dates, **Type**, **Keep forever** status and **Comment**.

To add a Measurement Group:

Click **Database > Measurement groups > Add**.

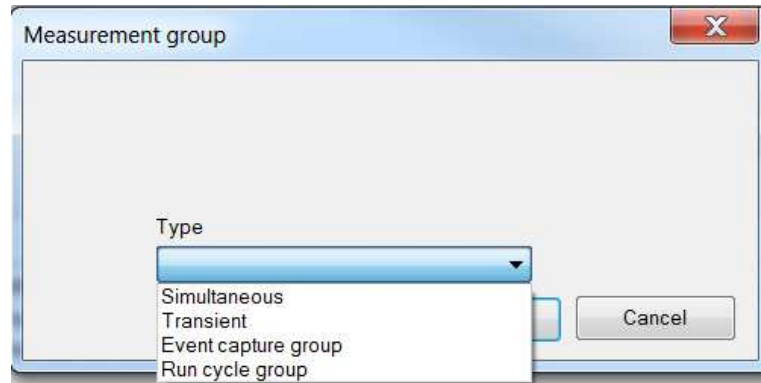

Figure 6 - 47.
Example of Measurement Group Types.

Type is the measurement group type.

Simultaneous: the single purpose of the simultaneous measurement group is to start measuring all the channels currently present in the measurement group at the exact same time. Note that a specific channel can be present only once in a measurement group.

Transient: the purpose of the transient group is to group measurement points that will collect data typically during a turbine run-up or coast-down. This was previously known as runup group or transient group in the earlier versions of @ptitude Observer. Useful for high speed rotating machinery.

Event capture group supports the event capture feature: time waveform points for pre- to post-event, data capture. The group has a fixed Fmax and no order tracking. The captured time waveforms enable detailed analysis of both very low frequency (mechanical) and very high frequency (electrical or generator related) oscillations. Useful for wind turbines and lower speed rotating machinery.

Run cycle group supports the run cycle capture feature: this is the functionality used in [SKF Rail Track Monitoring](#), to automatically capture track vibration data between stations.

Configure a Transient Measurement Group

Once a measurement point has been added to a measurement group, some point properties are not available on the measurement point screen and the input controls for them are disabled. These properties are now configured on the measurement group.

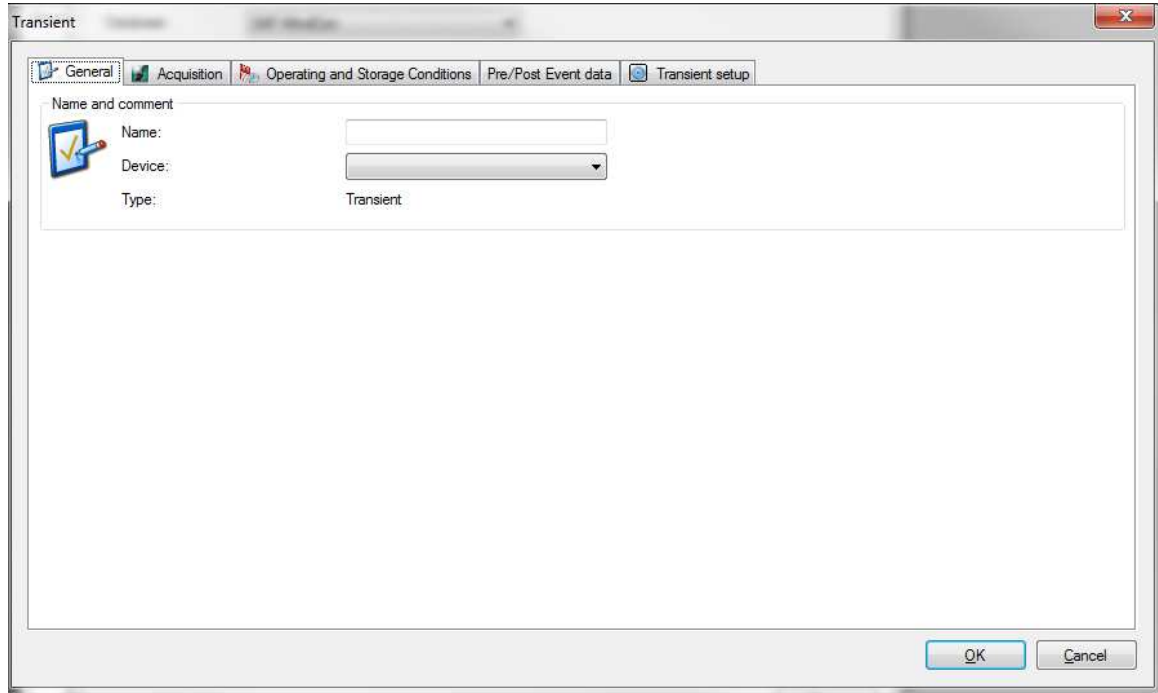

Figure 6 - 48.
Example of Measurement Group Configuration.

General Tab

The attributes are the same as in [General Tab](#) under Setting up Measurement Points and Alarms in System Configuration.

Acquisition Tab

The attributes are the same as in [Acquisition Tab](#) under Setting up Measurement Points and Alarms in System Configuration.

Operating and Storage Condition Tab

The attributes are the same as in [Operating and Storage Conditions Tab](#) under Setting up Measurement Points and Alarms in System Configuration.

Pre/Post Event Tab

It is used to control how data is stored before and after alarm event.

Transient Setup Tab - Simple configuration mode (available only when creating a new Transient Measurement Group)

Speed ranges for the run-up can define different stages of the run-up/coast-down.

Static data storage

Delta CPM is the setting for maximum speed change before storing static values.

Delta time is the setting for maximum time before storing static values.

Dynamic data storage

Delta CPM is the setting for maximum speed change before storing dynamic values.

Delta time is the setting for maximum time before storing dynamic values.

Transient state timeout specifies how long to remain in transient state when moving from transient state to normal state.

Transient closure time is the time to remain in the transient after reaching primary steady state.

Transient Setup Tab - Advanced configuration mode (available only when creating a new Transient Measurement Group)

Transient state timeout specifies how long to remain in transient state when moving from transient state to normal state.

Transient closure time is the timeout used before closing the transient and set its final type.

Rpm min (cpm) indicates the lower rpm (revolution per minute) limit for each range.

Rpm max (cpm) indicates the higher rpm (revolution per minute) limit for each range.

State defines whether this is a steady state or a run-up/down state.

Delta Trend (cpm) indicates the number of cycles per minute between storage of trend values. If this parameter is not reached within one minute, a trend will be stored.

Mean harm. (No. revolutions) indicates the number of revolutions of the shaft on which the mean value of the presented trend is based.

Max. time (s) is the maximum time between the storage of trend values.

Delta FFT (cpm) indicates the required change in speed between each spectra storage.

Max. time FFT (s) is the maximum time between the storage of FFT values.

Classification of Transients When Opening a Transient:

When transient data arrives at the monitor service, the monitor service will check if there is an active transient in progress for that measurement point. If not, a new transient is started and classified as following:

- If the speed reading is in a transient range that has no other ranges above it, it is classified as "Overspeed in progress".
- If the reading is in another transient range and in the lower half of that range, it is classified as "Run-up in progress".
- If the reading is in another transient range and in the higher half of that range, it is classified as "Coast-down in progress".

Classification of Transients When Closing a Transient

After the “Transient closure time” has elapsed without new transient values the transient will be closed. The state of the transient is then changed as:

- If it was classified as “Overspeed in progress” and the last reading stored also was in the overspeed range the classification is changed to “Overspeed”.
- If it was classified as “Overspeed in progress” and the last reading stored was outside of the overspeed range the classification is changed to “Overspeed – Coast-down”.
- If it was classified as “Run-up in progress” and the last speed reading was in the upper half of its speed range it is classified as “Run-up”.
- If it was classified as “Run-up in progress” and the last speed reading was in the lower half of its speed range it is classified as “Run-up aborted”.
- If it was classified as “Coast-down in progress” and the last speed reading was in the upper half of its speed range it is classified as “Coast-down aborted”.
- If it was classified as “Coast-down in progress” and the last speed reading was in the lower half of its speed range it is classified as “Coast-down”.

To add a measurement point to a transient measurement group:

1. Select a measurement point in the hierarchy view.
2. Go to General tab settings screen of Measurement point via **Properties** command. For help accessing the screen, refer to: [To edit a measurement point](#) in Setting up Measurement Points and Alarms.
3. Select the **IMx/MasCon device** to which this point is assigned.
4. Select a **Measurement group** to use from the drop-down list of measurement groups.

Optimal Settings for Transient Group

The following recommendations are to optimise the performance of a transient group.

- Use only vibration measurement points of Harmonic type.
- Do not use other dynamic measurement points in the same IMx device regardless of whether they are on different channels or not. Unrelated "slow points" should be in a separate IMx (16-channel) device.
- In dynamic data setting, select Save Time waveform only. Spectra is calculated from the waveform automatically. The setting applies for all dynamic data (for example, alarm/delta) but is placed in the "scheduled dynamic data storage" box.
- When using order-tracking, keep number of revolutions and maximum frequency to the minimum required.
- With non order-tracked harmonic measurement points, the harmonic calculation in transient should be done using an average of 2 revolutions unless the speed is sufficiently high. For high speed, configure the number of revolutions to correspond to approximately 0,1 seconds.

- With order-tracked harmonic measurement points in transient, 2 measurements/sec are expected with 16 channels (16 single channel points or 8 dual channel points) up to 25x and 8 revs average.
- Points used as simultaneous speed and process parameters should not be in the group. These parameters are stored anyway together with the points in the group. By keeping them outside they will be stored also when below the low speed cut-off. In case of missing data, it is useful to have something like speed always being stored to help determine whether the IMx has been online without speed input or the data acquisition has been unavailable.

Note: There might be issues with using a laptop when testing, especially with a mechanical drive (not an SSD) getting enough SQL Server performance. Lots of small file access like running a backup software on the same disk should be avoided.

Configuring an Event Capture Group

Each IMx unit can have only one event capture group. The event capture group supports time waveform points for pre- to post-event, data capture. The group has a fixed Fmax and no order tracking.

- When trying to add a second event capture group for an IMx, it will not be possible to enter the **Device** and save the group.

Click the **Database** tool and then select **Measurement groups**. In the **Measurement groups** dialog, click **Add**. Select the **Type** as Event capture group. The **Event capture group** dialog opens.

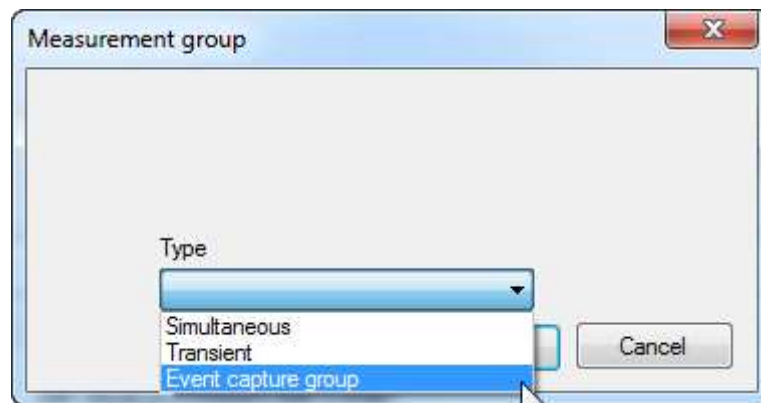

Figure 6 - 49.
Example of Measurement Group Type, Event Capture Group.

OR

In the hierarchy, right-click the machine to which the event capture group is to be added. Select **Add** and then click **Event Capture group**.



Figure 6 - 50.
Example of Machine > Add > Event Capture Group.

The **Event capture group** dialog opens. In the **General** tab, **Type** defaults to Event capture group.

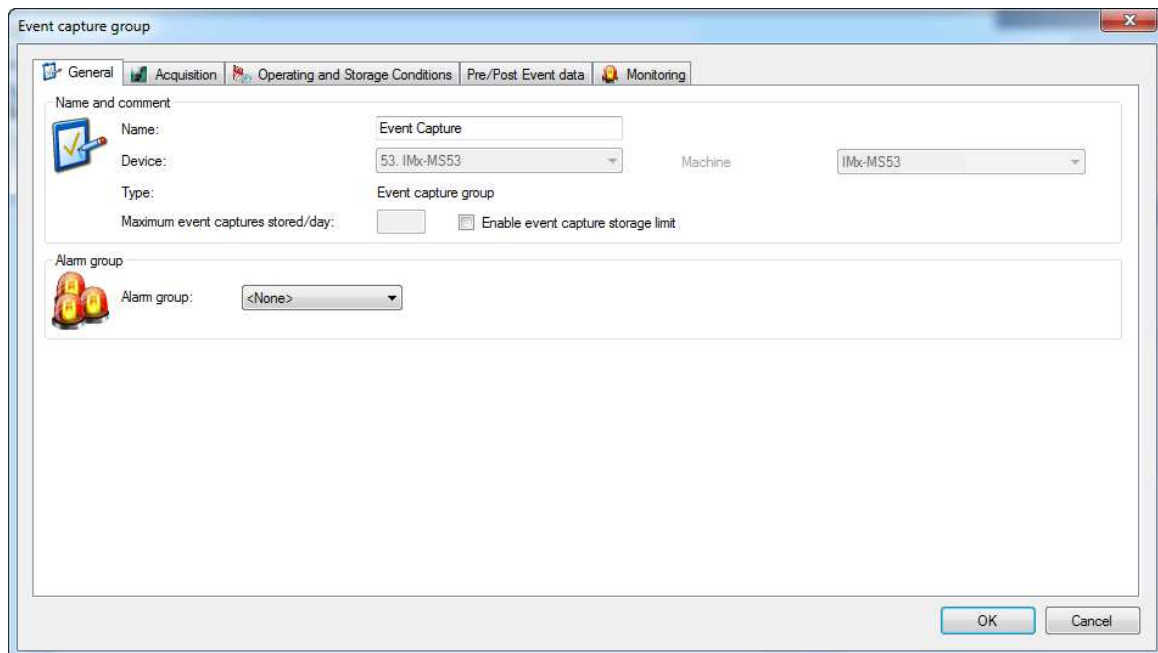

Figure 6 - 51.
Example of Event Capture Group Dialog, General Tab.

- Enter the group's **Name**. **Device** and **Machine** default values appear.
- **Maximum event captures stored/day** defaults to 0 (meaning unlimited) and unavailable. If the **Enable event capture storage limit** checkbox is selected, the **Maximum event captures stored/day** counts all alarm-based event captures with status "Done". The value can be set up to 99 999. When the maximum number of events stored per day is reached, an alarm will be generated each time the system tries to store another event capture.
 - It is always possible to store a manual capture, even after the maximum number of event captures has been reached. Storing an event capture manually will not generate a system alarm even if the maximum number of captures per day has been reached.

- Open the **Acquisition** tab. **Acquisition Type** is locked to Fixed Frequency.

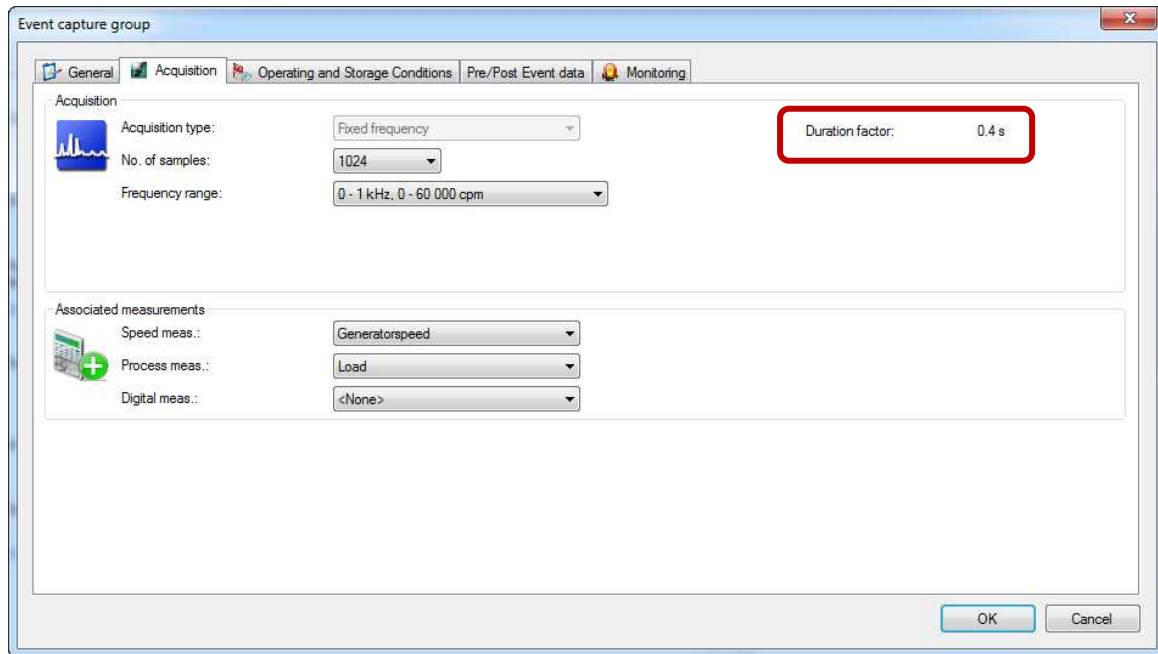

Figure 6 - 52.
Example of Event Capture Group Dialog, Acquisition Tab.

- Select the **No. of samples** in steps (1024, 2048, 4096...up to 16384).
- Select the **Frequency range**.

The duration factor is calculated as shown in the following table.

Table 6-1.
Duration Factor Calculations.

Fmax	Sample Rate	1024 Samples	2048 Samples	8192 Samples	16384 Samples
1000	2560	0.4 s	0.8 s	3.2 s	6.4 s
2000	5120	0.2 s	0.4 s	1.6 s	3.2 s
5000	12800	0.08 s	0.16 s	0.64 s	1.28 s
10000	256000	0.04 s	0.08 s	0.32 s	0.64 s

The calculated **Duration factor** must be more than 0.16 seconds. If the **Duration factor** is too small to capture an event, an error is displayed, Figure 6 - 53. The user can increase the number of samples (or potentially reduce the Fmax and associated sample rate) to correct this.

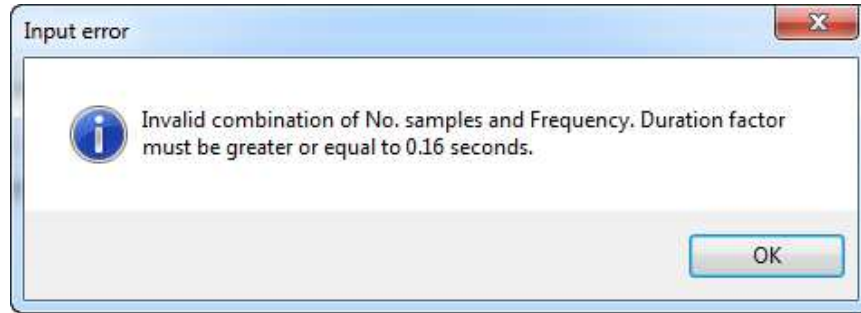

Figure 6 - 53.
Example of Input Error.

- Set up the desired associated measurements.
- Open the **Operating and Storage Conditions** tab.
- Select the desired Operating Condition **Type** values for the group to be stored. (This could be on speed, process or digital conditions.)

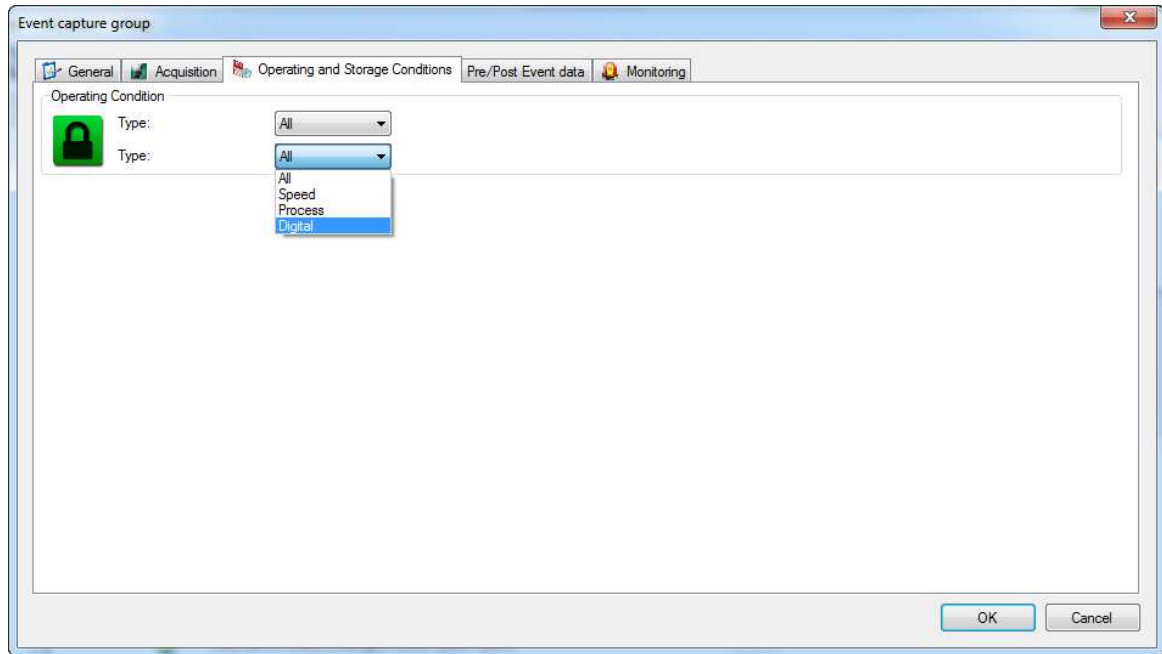

Figure 6 - 54.
Example of Event Capture Group Operating and Storage Tab.

- Open the Pre/Post Event data tab.

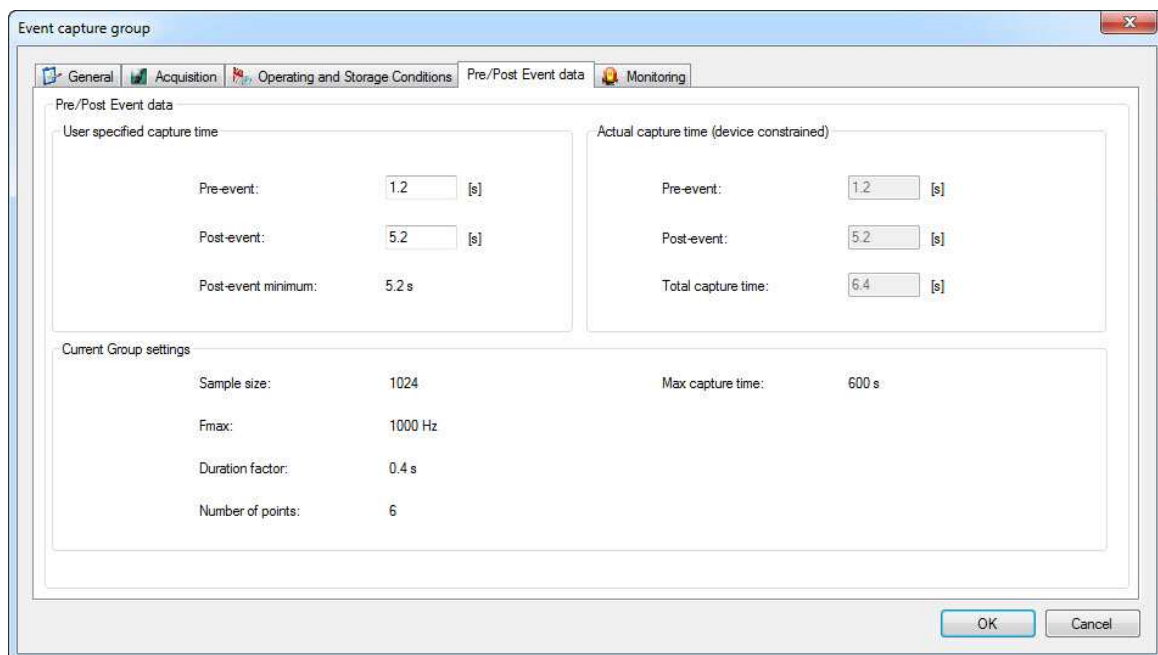

Figure 6 - 55.
Example of Event Capture Group Dialog, Pre/Post Event Data Tab.

- The number of seconds for the **Pre-event interval** and the **Post-event interval** can be set. These intervals are included in the total measurement time calculated.

The following rules apply:

- Duration factor has a minimum of 0.16 seconds (to capture the event).
- Pre-event buffer has a minimum of 1x the duration factor.
- Post-event buffer has a minimum of 2x duration factor or at least 5 seconds.

The Actual capture time (device constrained) elements are displayed at the right.

- @ptitude Observer recalculates the total measurement time whenever the number of seconds for the **Pre-event interval** or the **Post-event interval**, is updated.

Current Group settings are displayed in the lower section of the screen. If there is a problem with the CPU version in the selected configuration, a message displays at the bottom of the screen.

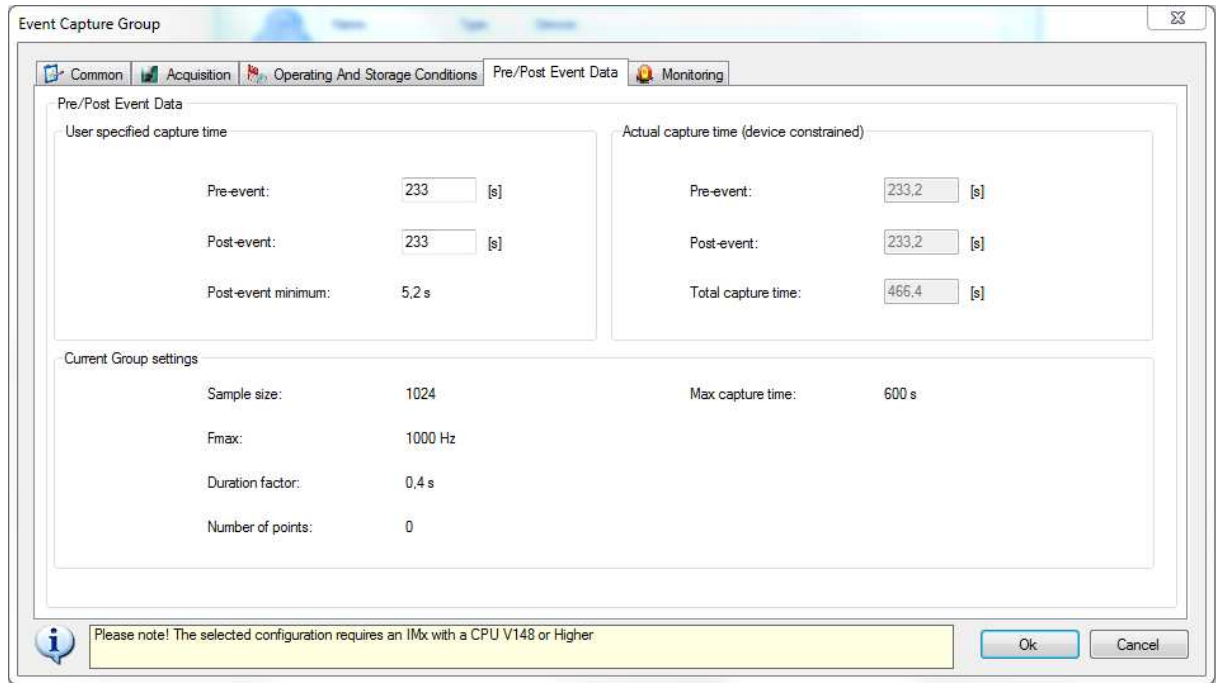

Figure 6 - 56.
Example of Event Capture Group Dialog, Pre/Post Event Data Tab with CPU Information Message.

- Open the **Monitoring** tab.

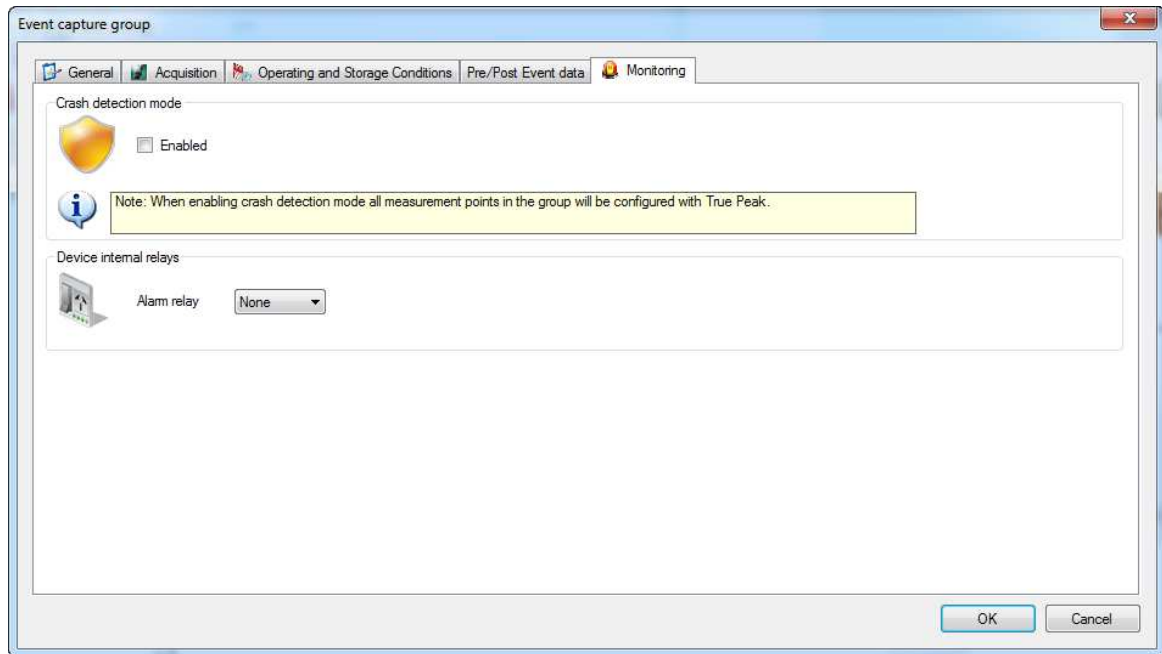

Figure 6 - 57.
Example of Event Capture Group Dialog, Monitoring Tab.

- Enable/disable crash detection mode. When crash detection mode is enabled, the IMx device is put in a very responsive state to quickly detect machine tool crashes based on vibration events and, if required, shut the

machine down to avoid severe damage (shut down requires the use of relay outputs). Crash detection mode applies specific settings, such as the high pass filter cut-off frequency, to all measurement points that belong to the event capture group.

- Select the **Alarm relay** that the event capture group will use. Click **OK** to create and save the new event capture group. The event capture group will display as the first node beneath the machine. Drag and drop functionality allows the group to be moved only within the same machine. Event capture points may be re-ordered only within the group.

To add an event capture measurement point to an event capture group:

- Right-click the event capture group in the hierarchy and select **Add > Meas. point** from the resulting menu. The **Meas. point** dialog opens.

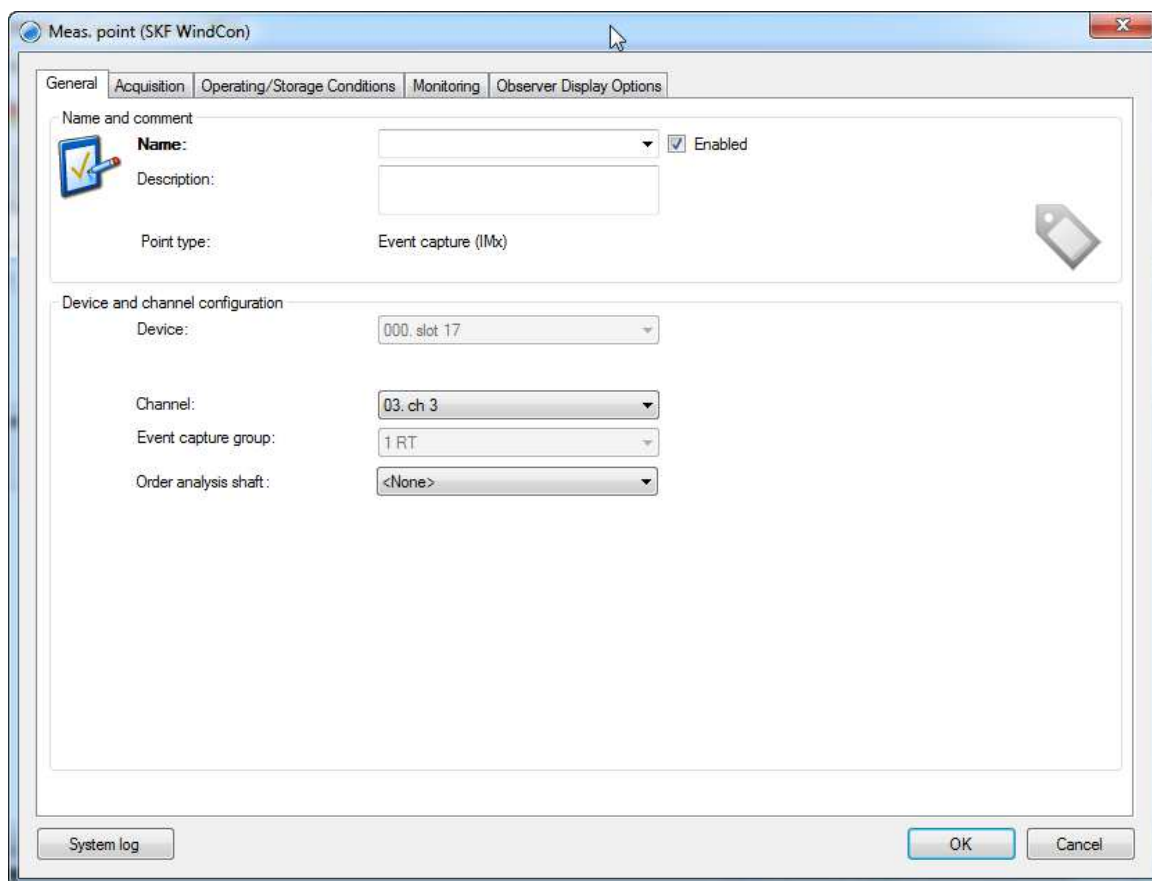

Figure 6 - 58.
Example of Event Capture Measurement Point, General Tab.

One point per channel can be added (up to the device channel limit). The maximum frequency per channel is 10 kHz up to 12 channels, for more than 12 channels, the limit is 5 kHz per channel.

- In the **General** tab enter a **Name** for the point.
- Check the **Enabled** box to activate the event capture point.
- The **Device** and **Event capture group** are populated.
- Select a **Channel**.

- Select the **Order analysis shaft** if machine part shafts were specified. The order analysis shaft is the shaft on the machine that is the basis for analysing the orders of running speed.
- Go to the **Acquisition** tab.

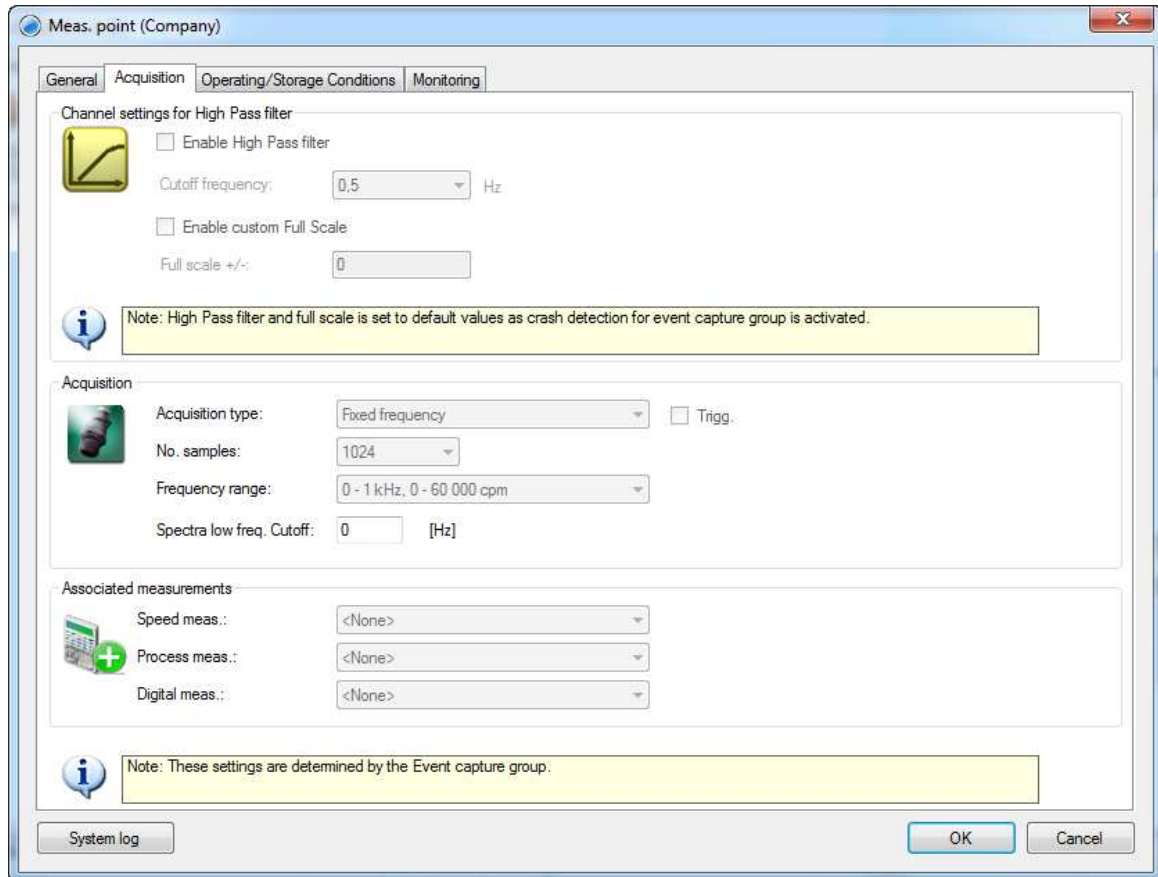

Figure 6 - 59.

Example of Event Capture Measurement Point, Acquisition Tab with Crash Detection Mode Enabled.

Channel settings for High Pass Filter are locked and uneditable on all measurement points belonging to an event capture group that has crash detection mode enabled. When crash detection mode is enabled:

- High pass filtering is also always enabled. The **Cutoff frequency** defaults to 0.5 Hz.
- Full scale is also always enabled. Full scale is the range that corresponds to 6 V input on the channel.

When crash detection mode is disabled on an event capture group:

- High pass filtering can be enabled and the **Cut-off frequency** can be set to either 0.0625, 0.125, 0.25 or 0.5 Hz.
- Custom full scale can also be enabled when high-pass filtering is enabled. The value 0 corresponds to the full range of channel. Full scale can be set from between 0.8% to 94% of the maximum range of the channel.

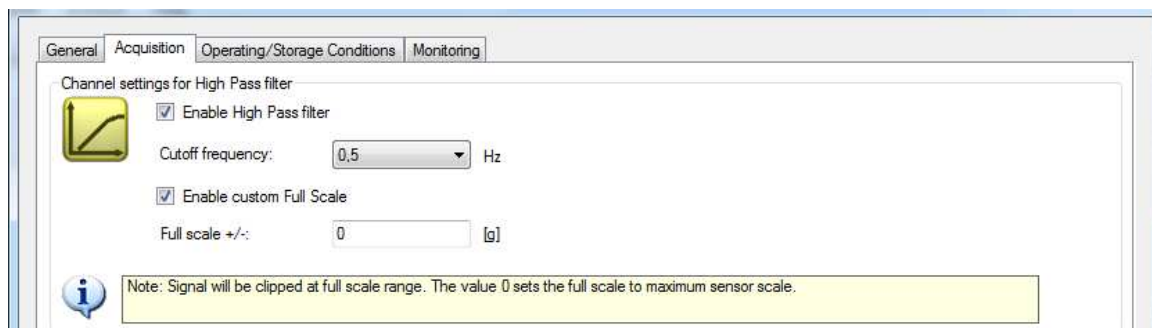

Figure 6 - 60.

Example of Event Capture Measurement Point, Acquisition Tab with Crash Detection Mode Disabled.

- **Acquisition type**, **No. samples** and **Frequency range** are read only. These settings are determined by the event capture group. Enter the Spectra **low freq.** Cutoff value in Hz. The low frequency cutoff is used as a filter to limit unwanted peaks or "ski slopes" at the start of the FFT. For example, setting this value to 5 will zero out all values between 0 and 5 Hz in the FFT.
 - The **Operating/Storage Conditions** tab settings are also determined by the event capture group.
- Go to the **Monitoring** tab.

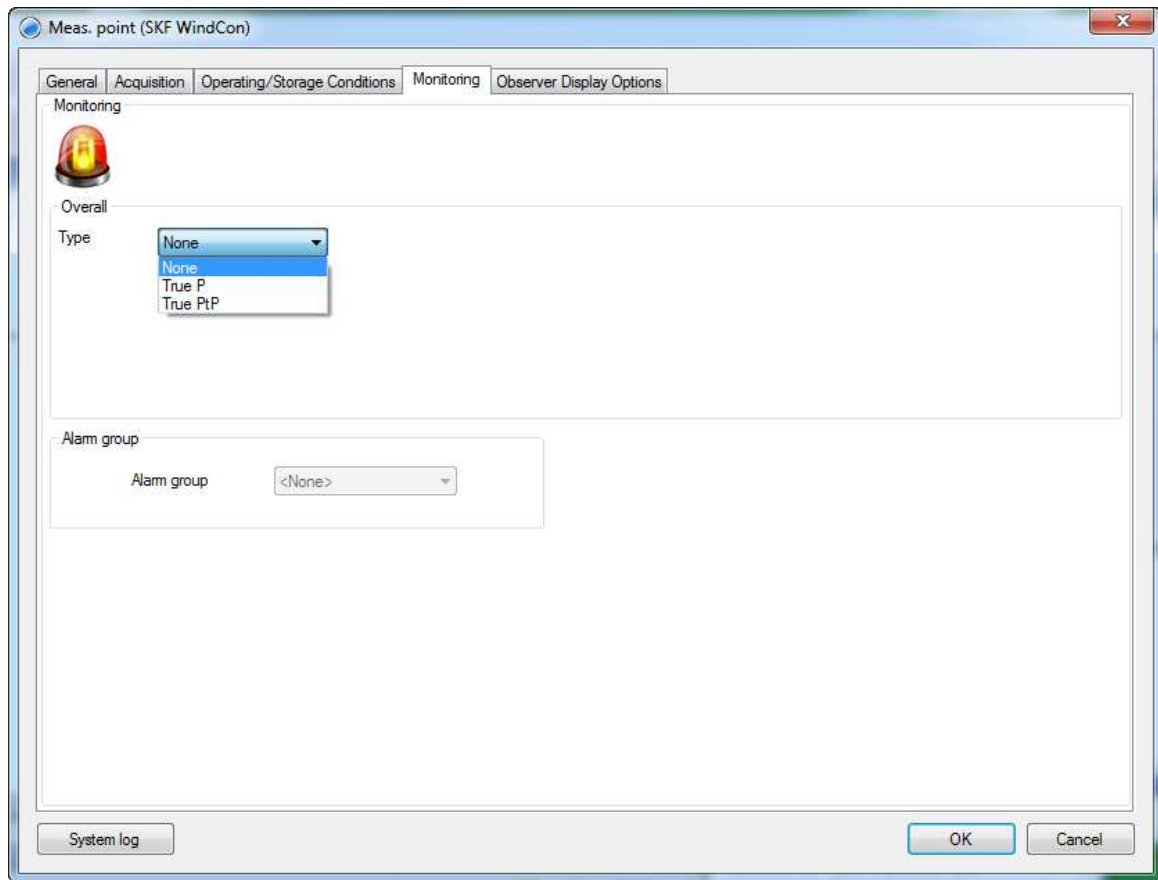

Figure 6 - 61.
Example of Event Capture Measurement Point, Monitoring Tab.

- **Type** True Peak and True Peak to Peak are supported. True Peak is selectable only when high-pass filtering is used.
 - When crash detection mode is enabled on the event capture group, **Type** is locked to True Peak.
 - When crash detection mode is disabled on the group, but high pass filtering is enabled on the measuring point, True Peak can be selected.

When True Peak or True Peak to Peak is selected, additional fields appear in the Alarm section.

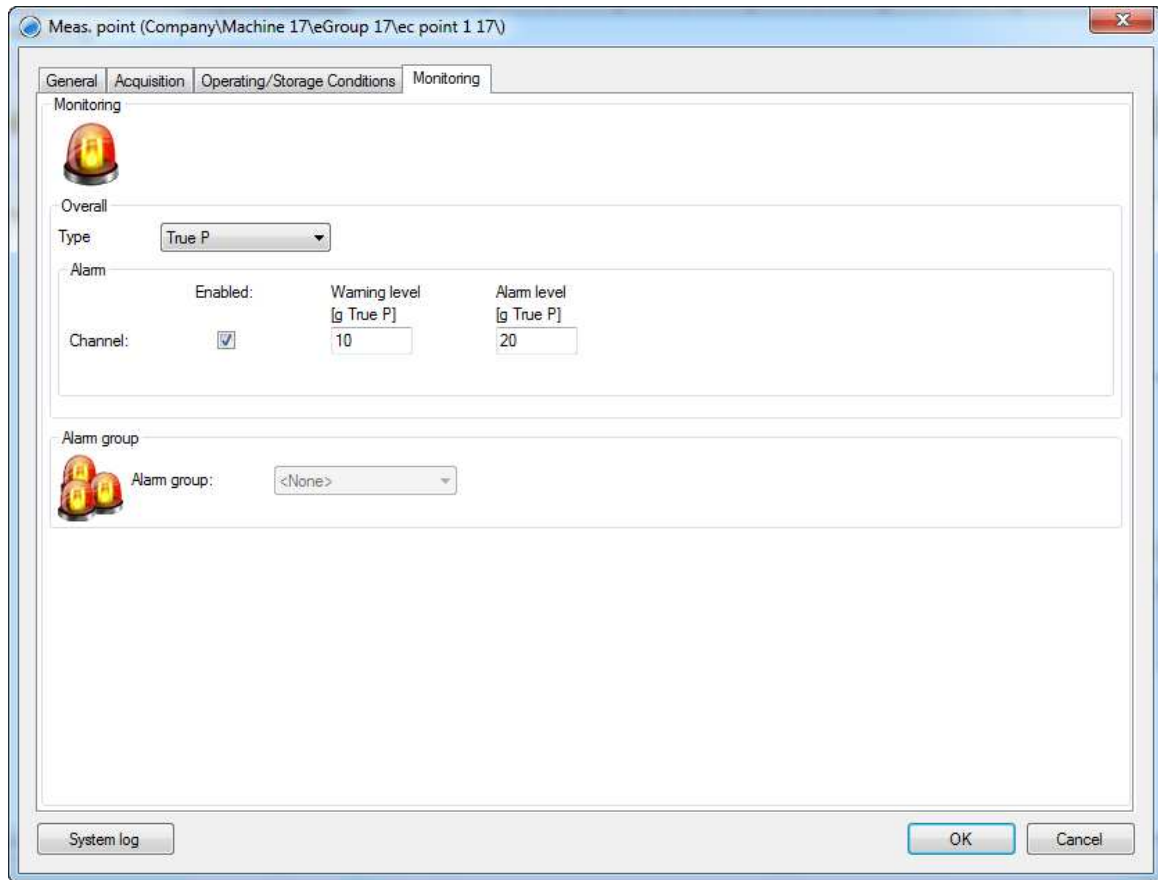

Figure 6 - 62.
Example of Event Capture Measurement Point, Monitoring Tab, Alarm Section.

- Check the **Enabled** checkbox to trigger storage of an event capture for the channels in the group.
- Set the **Alarm** level and **Warning** level. If the point is in an alarm group, event captures from all channels in the group will be taken upon alarm. Warning and Alarm should not use levels above 90 % of configured Full Scale.
 - When the point's signal drops below the specified alarm threshold, there is a one minute delay before the event capture trigger is armed. This delay prevents the system from initiating a capture at every reboot when a point is above the alarm threshold.
- Select an **Alarm group**.
- Click **OK** to create the measurement point.

The Trend plot function is enabled for event capture measurement points which have alarms enabled. Select the event capture measurement point in the

hierarchy view and then click Trend  to display the plot.

Options

The Options interface offers different system settings for the @ptitude Observer application and database. These range from new measurement point settings to backup settings and are typically applied to all users in the database.

Database is the database to which the general settings of options are to be applied. Select a database from the drop-down list.

- From any tab within the Options interface, click the **Default settings** button to restore the system default values for the settings on that tab.

General Settings Tab

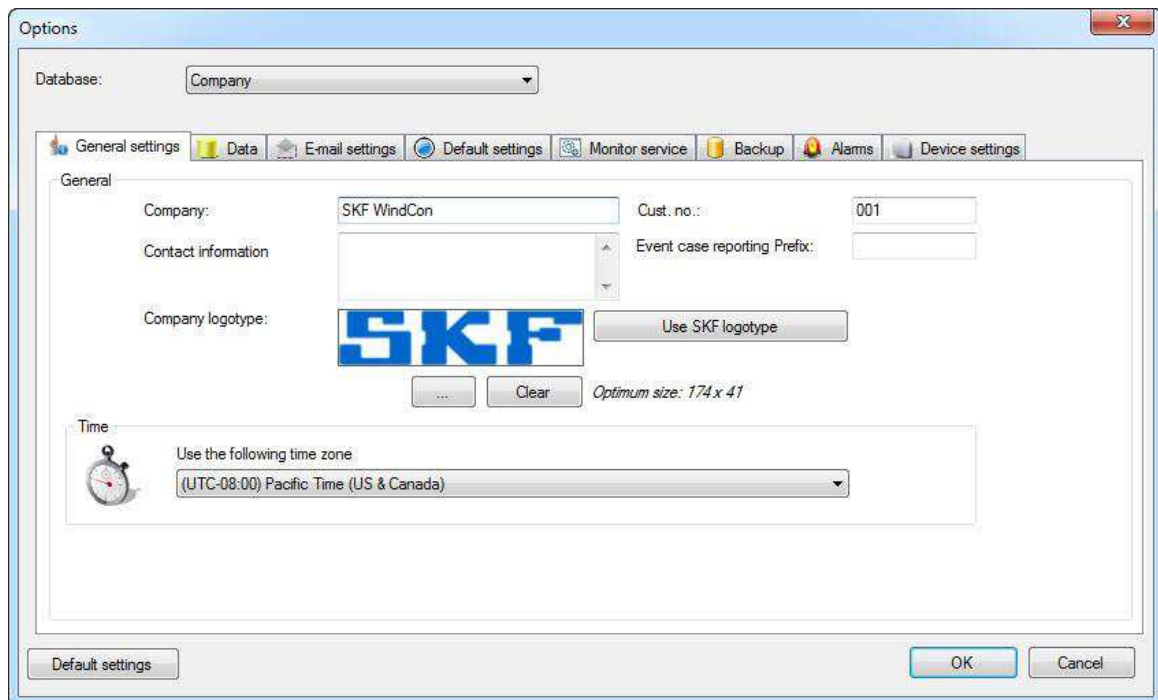

Figure 6 - 63.
Example of Options General Settings.

Company name to which the selected database belongs.

Contact information is for the company. It should normally contain the name and the address of the company.

Cust. no. is an optional text field where one can enter a customer number if desired.

Event case reporting Prefix is a prefix text that is applied to the case number when creating event cases and reports. If using multiple databases, the prefix should be different for each database in order to create completely unique event case numbers.

Company logo is used in event case reporting. The SKF logo, Observer logo or own company logo may be used.

Time zone enables the selection of any time zone available on the computer where the database is created. This can only be changed by users with system configuration rights. Observer will use this time zone for all time date stamps in the database.

Data Tab

Figure 6 - 64.
Example of Options Data Settings.

Automatically delete old data will cause the monitor service to remove old data from the database once data is older than the specified range, if **Enabled** is checked. Specified ranges can differ for different types of data.

Time specifies at which time of the day the removal will take place. Removing a large amount of data from the database can be time consuming. In such case, it is recommended to set the time to a non-office hour.

Trend rolling buffer size determines the size (number of values) of the built-in trend rolling buffers. The default size is 3 000.

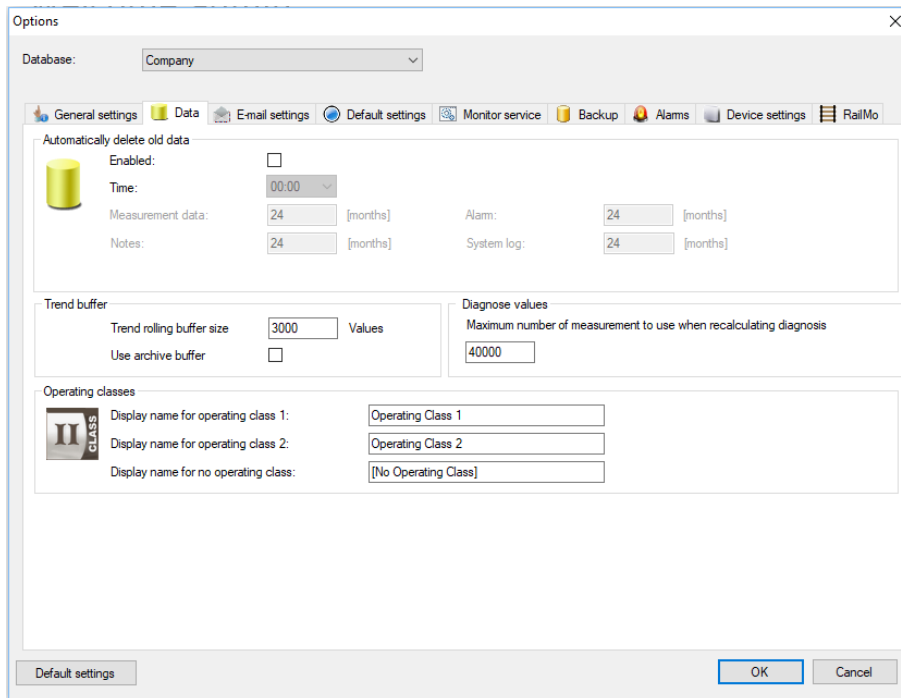
Use archive buffer turns the archive buffer on (if checked) or off (if not checked). The archive buffer can store up to 80 000 values for each measurement point.

Diagnose values allows control over the maximum number of values used in a [Diagnosis](#) calculation or recalculation. The default setting is 40 000 values.

Operating Classes are different operating conditions in which a machine normally operates. With the use of multiple gating measurement points, different alarm levels can be set depending on which operating class a machine is in. @ptitude Observer supports two operating classes for use with IMx devices.

Display name for operating class 1 and 2 – Enter the text to display in the user interface (for example in the Process Overview) when the machine is operating in either of the two operating classes.

Display name for no operating class – Enter the text to display when the machine is not operating in either of the two operating classes.

- Only individuals with “Config System” rights can change the operating class display names.

E-mail Settings Tab

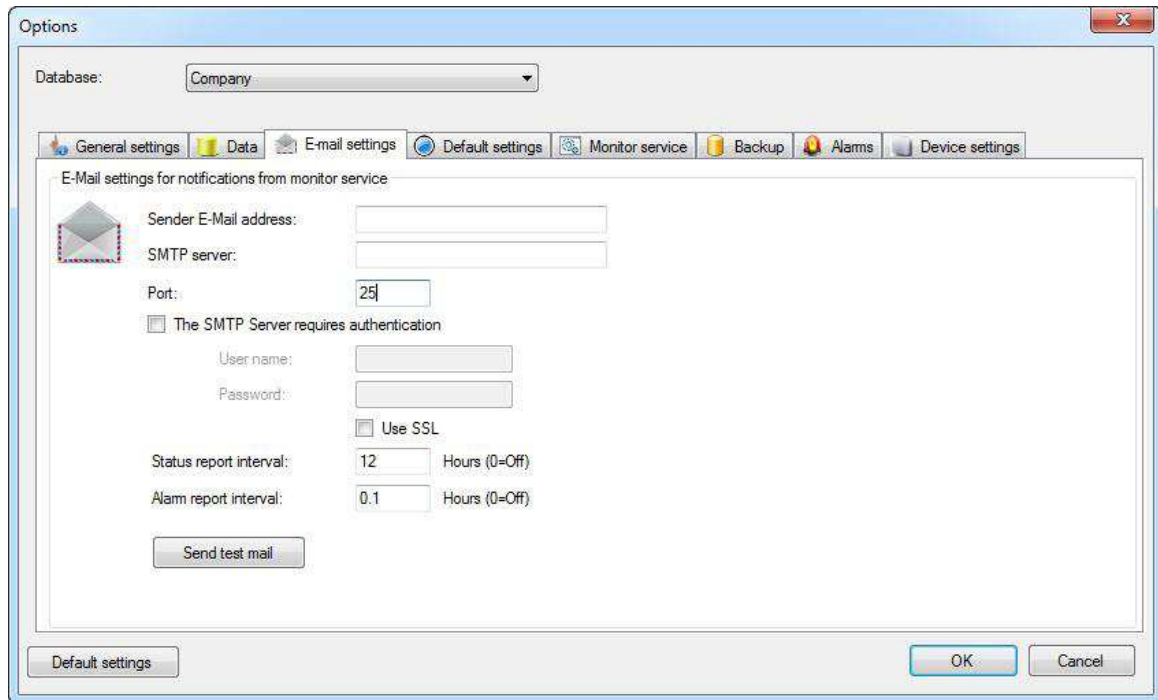

Figure 6 - 65.
Example of Options E-mail Settings.

Sender E-Mail address is the email address to which the monitor service will send notifications.

SMTP Server is the SMTP server that should be used for sending e-mail messages from the monitor service.

Port needs to be set to the port of the SMTP Server.

The SMTP Server requires authentication must be checked if the SMTP Server requires that a user name and a password is supplied.

User name is then the user name for the SMTP Server

Password is then the password for the SMTP Server

Use SSL must be checked if the SMTP Server requires communication through SSL (Secure sockets layer)

Status report interval sets how often status reports from the monitor service should be sent by email. The status report of the monitor service contains a number of parameters about the system, including database size and condition.

Alarm report interval sets how often alarm reports from the monitor service should be sent by email. The alarm report of the monitor service contains alarm information for alarms that have occurred since the last alarm report.

Send test mail sends out a test mail which can be used to confirm that the email settings are correct.

Default Settings Tab

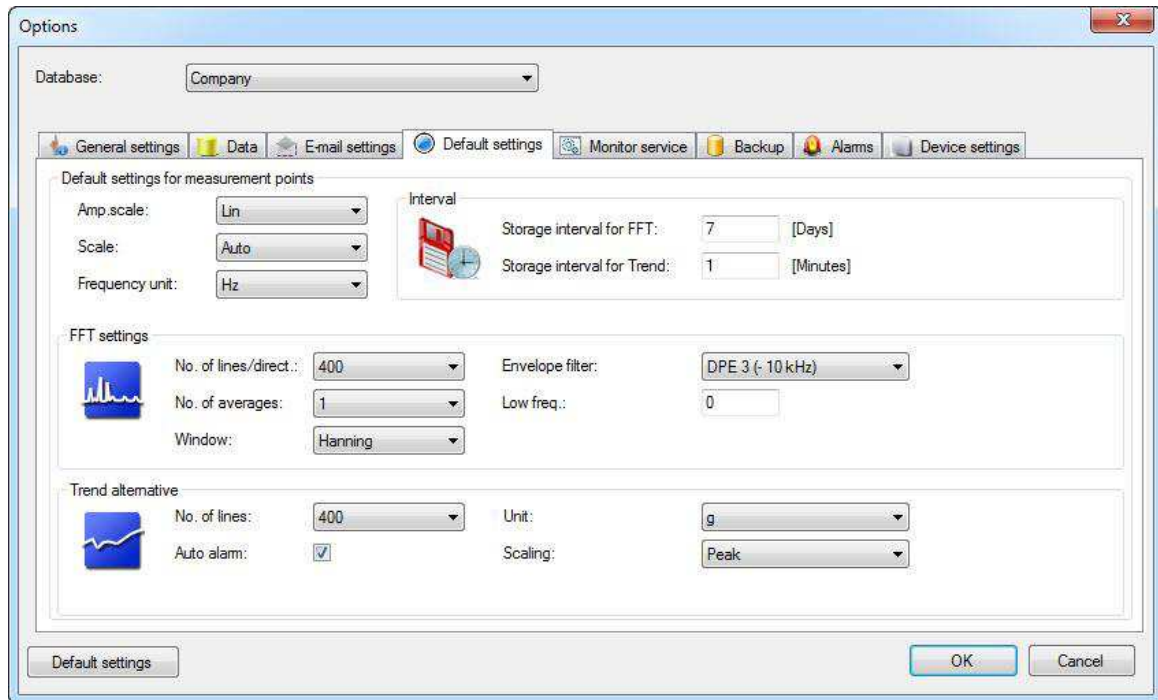

Figure 6 - 66.
Example of Options Default Settings.

The Default settings tab allows the default settings for new measurement points of the selected database, to be configured. When a new measurement point is created, these settings will be automatically selected for the new measurement point on the measurement point screen. For more information refer to [Setting up Measurement Points and Alarms](#) in System Configuration.

Note the **Default settings** button (lower left) restores the settings on this tab to their system default values.

Monitor Service Tab

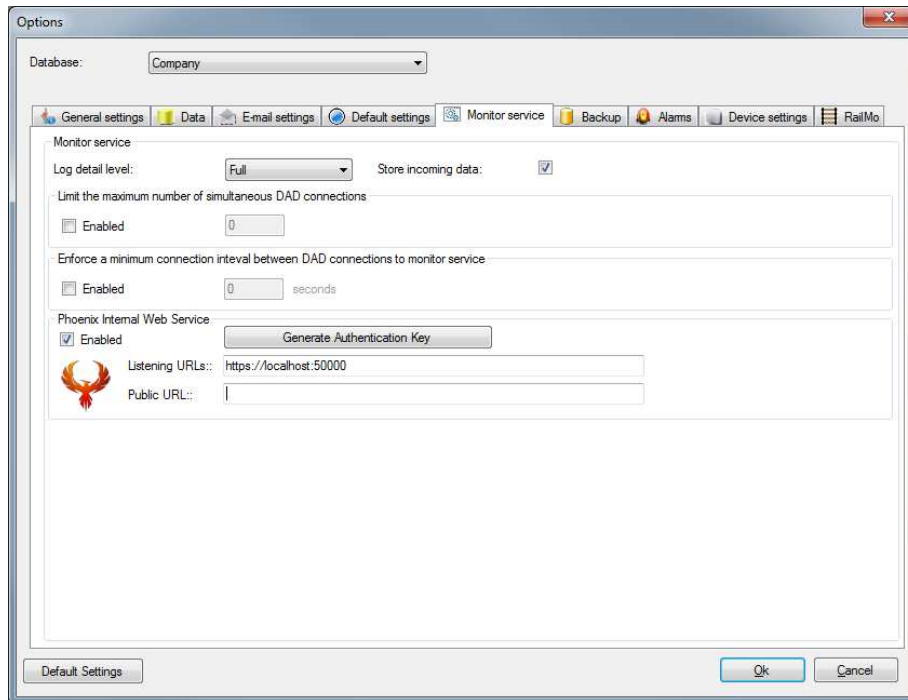

Figure 6 - 67.
Example of Options, Monitor Service Settings.

Log detail level determines which type of event(s) are to be stored in the monitor event log. There are five levels to choose from:

None: Nothing is logged in the event log.

Minimal: Only severe errors are logged.

Normal (default): Severe and minor errors are logged.

Detailed: Store events (and severe and minor errors) are logged.

Full: All events that occur are logged. This setting can be used for error tracking.

Store incoming data can turn on and off the data storage in the database. This checkbox should normally always be checked. Under certain circumstances such as during service or during commissioning this can be unchecked to avoid storing invalid data.

Limit the maximum number of simultaneous DAD connections can be used to prevent all DADs in the system from connecting at the very same time to upload the collected data to the database. This can be useful when having a system setup where the DADs connect on a regular interval, for example once per day to upload their data and then disconnect again.

Enforce a minimum connection interval between DAD connections to monitor service can be used to spread out the workload of the monitor service on sensitive computers.

Phoenix Internal Web service – the internal web service can be used to retrieve data from the Observer database through a web service API. The SKF @ptitude Observer Phoenix Data Service API is a HTTP-based RESTful

API that uses OAuth 2.0 for authorization. API request and response bodies are formatted in JSON ((JavaScript Object Notation).

The REST interface is provided by the Observer Monitor Service. To use the REST interface the Monitor service must be installed, started and configured.

Select **Enabled** to enable the REST endpoint.

Click the button **Generate Authentication Key** to generate a permanent encryption key used for authentication. If no permanent key is generated a temporary is generated when monitor starts.

Add **Listening URLs** to specify on which protocol, address and port the REST endpoint should listen for incoming requests. This is a list separated by a comma sign (“,”).

Examples:

https://localhost:50000 will listen on the https protocol on the host only interface “loopback” on port 50000.

https://10.11.12.13:8080 will listen on the https protocol on the network interface 10.11.12.13 on port 8080.

https://computer.dns.name:8080 will listen on the https protocol on the network interface allocated to DNS name computer.dns.name on port 8080.

https://computer.dns.name:8080,https://10.11.12.13:8080,https://localhost:50000 combines all the earlier examples.

URLs are built up of <protocol>://<IP address or hostname>:<port number>.

Protocol: The recommended protocol is https which is encrypted communication. Protocol http is also supported but not recommended since sensitive information is exchanged, like username and password. Please note that using https requires some additional configuration of the windows machine hosting Observer monitor.

IP address or hostname: Specify on which network interface the REST service should listen for incoming requests. Typically, this is represented by a physical Network Interface Card (NIC) for connection between a computer and a private or public network. However, it can also take the form of a software-only component such as the loopback interface or Virtual Private Network (VPN) interface.

Examples: loopback, computername.companyname.com, 192.168.1.10

There is a special interface called “*” which should be used with care since it’s the wildcard interface, which means all interfaces.

Port: The Port where the REST interface should listen for incoming requests. The default is 50000, but any non-allocated port can be used. Double check the firewall to identify which ports are blocked for incoming requests.

Public URL: For cloud scenarios in combination with SKF Rail Track Monitoring the Public URL denotes the URL where the service is reached from outside of the cloud. The cloud provider will map a public IP address or DNS name to the IaaS instance.

On changing the Phoenix configuration and clicking **OK**, the Observer Monitor will react within seconds and open the REST interface. This can be verified in the Observer Monitor log file.

If the port configured is already in use by another process on the computer, Observer monitor will indicate this in the log file. Select another free port or terminate the process that already is using it.

Backup Tab

Backup automates daily backups for SQL Server. The backups are done by the @ptitude Observer Monitor service at the specified interval. Therefore, @ptitude Observer Monitor must be running for the backups to be created

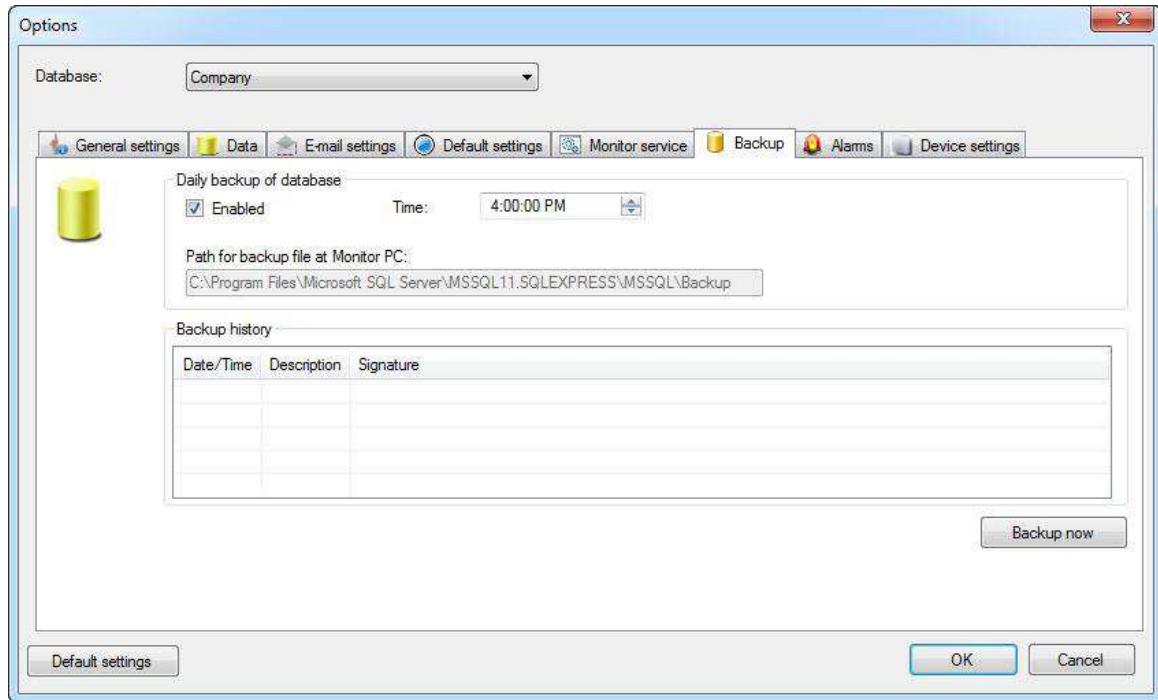

Figure 6 - 68.
Example of Options Backup Settings.

Database is the database to which backup options are to be applied.

Enabled causes daily backup of the database.

Time indicates when the backup job should be actioned.

Path for backup at Monitor PC specifies the location where the backup files should be saved on the monitor computer.

Backup history displays the history of backups done.

Backup now causes an immediate backup. Backups are stored by @ptitude Observer SQL Server Database Administrator.

Note that with SQL Server Express, this is the only way to automate backups of @ptitude Observer databases.

With the full version of Microsoft SQL Server it is still possible to configure the backups with @ptitude Observer SQL Server Database Administrator.

Alarms Tab

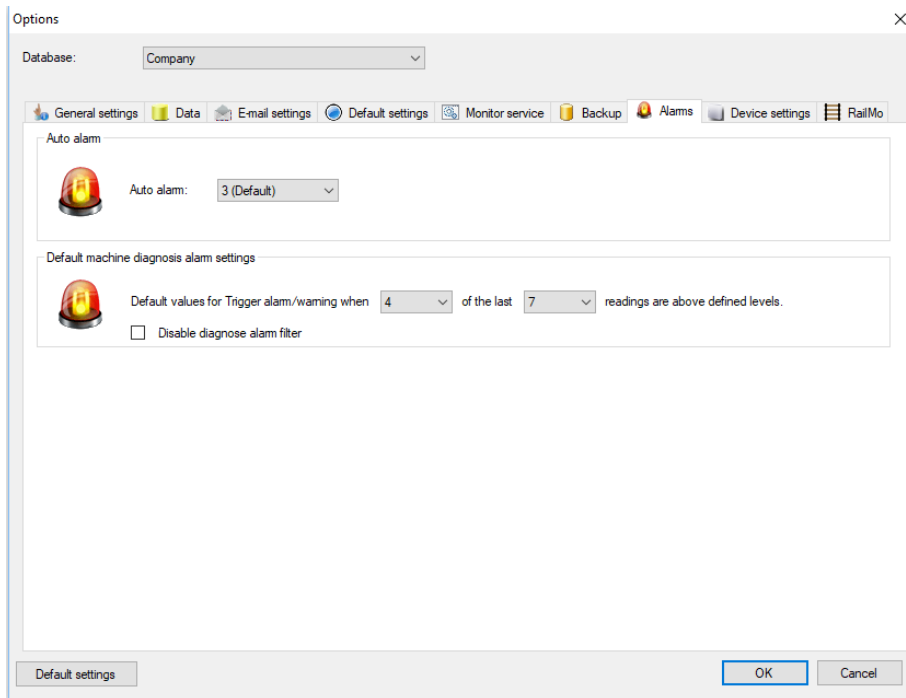

Figure 6 - 69.
Example of Alarms Settings.

Auto alarm value is the setting for the diagnosis auto alarm. It sets the alarm level between 3 (default level) and 10 (conservative level) for the auto alarm in the diagnosis graph.

3 (Default) sets the auto alarm level fairly close to previous measurements.

10 (Conservative) sets the auto alarm level to high.

Default machine diagnosis alarm settings sets the alarm hysteresis default values for calculating and triggering an alarm/warning. The method is to set the "Default values for Trigger alarm/warning when n (1 to 30) of the last n (1 to 30) readings are above defined levels". The default values are 4 and 7.

Disable diagnose alarm filter relates to an alarm filter that prevents multiple alarm events being generated due to successive measurements being in alarm.

With the filter enabled (default), an alarm is generated the first time the alarm conditions are met but further alarms from subsequent measurements are not generated unless that initial alarm is acknowledged. If acknowledged, the next measurements meeting the alarm criteria generate an alarm and the filtering process repeats.

With the filter disabled (checked), alarms are generated every time measurements exceed the alarm criteria. This corresponds to the default behaviour in @ptitude Observer 10.2 and earlier.

Device Settings Tab

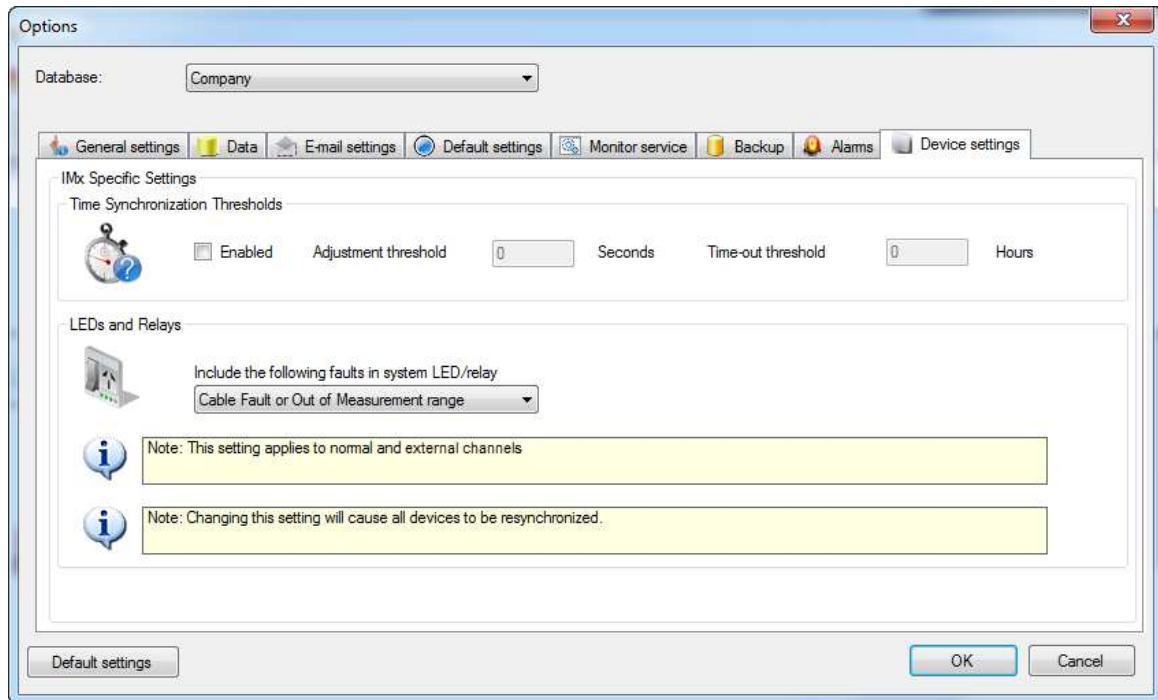

Figure 6 - 70.
Example of Device Settings Tab.

In the IMx configuration, if either **Same as monitor server (default)** or **Use IP address** as the Time server (NTP server) option were selected, then time synchronization thresholds can be enabled so as to generate critical system alarms if time synchronization is lost.

To configure the time synchronization thresholds:

- Select the **Enabled** checkbox to enable threshold alarm generation.
- Enter the desired number of seconds for the **Adjustment threshold (seconds)**. The adjustment period is the difference between the time of the NTP client and the time of the NTP server. If the time difference exceeds the Adjustment threshold specified, an alarm is created. The alarm states: "The time difference between the device (IMx name) and the NTP server has exceeded the threshold."
- Enter the desired number of hours for the **Time-out threshold (hours)**. The NTP client tries to communicate with the NTP server at specific intervals to get the current time. If the time period the NTP client cannot communicate with the NTP server exceeds the Time-out threshold specified, an alarm is created. The alarm states: "Device (IMx name) has not been able to synchronize with the NTP server."
- **Include the following faults in system LED/relay** applies to all IMx devices and IMx types. This setting is written to the IMx configuration file upon synchronization.
 - None is the default setting for new databases and upgrade databases.
 - Cable Fault includes the cable fault on a channel only.

- Cable fault or out of measurement range includes the cable fault on a channel or a measurement point out of range in the system fault LED and Relay.
 - If this setting is changed, then all IMx devices in the database will be synchronized automatically by the Monitor service.

Delete Data

Delete data interface can delete measurement data based on certain criteria or filter settings for the selected database.

Data Miner

The data miner allows for complex data mining from the Observer database with the results available in three different formats; table, trend and bar.

This interface makes it possible to compare measurement points, machines or even specific diagnoses.

Expert users can also design custom statistical views and, if approved, these can be shared with other Observer users around the world through the SKF Online Repository (SKF OR).

Note that to create custom statistical views, a very good understanding of the Observer database structure is required.

On-line

The On-line menu provides the following interfaces.

- [IMx/MasCon Devices](#)
- [OPC servers](#)
- [Monitor Service Viewer](#)
- [Balancing](#)
- [Event log](#)

IMx/MasCon Devices

This interface brings up the IMx/MasCon devices screen. Refer to [Creating IMx/MasCon Devices and Channels](#) in System Configuration.

OPC Servers

OPC Servers interface brings up the OPC Servers and channel settings screen. Refer to [Creating OPC Servers and Channels](#) in System Configuration.

Monitor Service Viewer

The monitor service viewer can be used to view the interface of the monitor service remotely from Observer. It is possible to view all events occurring in the service as well as database status, DAD status, OPC status and the number of clients currently connected.

Balancing

On-line balancing is a tool for multi-plane balancing designed especially for turbines. However, it is just as useful on smaller machines. The on-line balancing in @ptitude Observer uses IMx, MasCon16/48 devices harmonic measurement points because of their simultaneous measurement capability. On-line balancing supports a maximum of 15 planes over 5 states with up to 40 measurement points.

For successful balancing, the phase must be stable and it should be possible to make changes on the actual speed range under run-up/down group. Polar plot can be used to determine if the phase is stable. If the phase is not stable, the problem is not only unbalance but also can be something else. Therefore, in such case further normal analysis of the machine is required. On a horizontal machine with laying shafts, the best balancing direction is the weakest direction.

In order to have an accurate balancing analysis of a machine, it should be certain that the problem lies within the unbalance characteristics. The following are some examples of other problems with characteristics that can be similar to unbalance.

- Bearing problems
- Bearing slip
- Misalignment
- Weak foundation

Balancing interface has the following functions.

- [Balance](#)
- [ICM](#) (influence coefficient matrix)

Balance

Follow the steps described below in order to have an accurate balancing analysis of a machine.

Step 1: Choose an ICM (influence coefficient matrix) of the selected database. ICMs are created via the ICM interface.

The list of ICMs are shown by names and dates created. ICM contains the necessary information about the machines behaviour needed to eliminate unbalance which is stored in the database for new on-line balancing in the future.

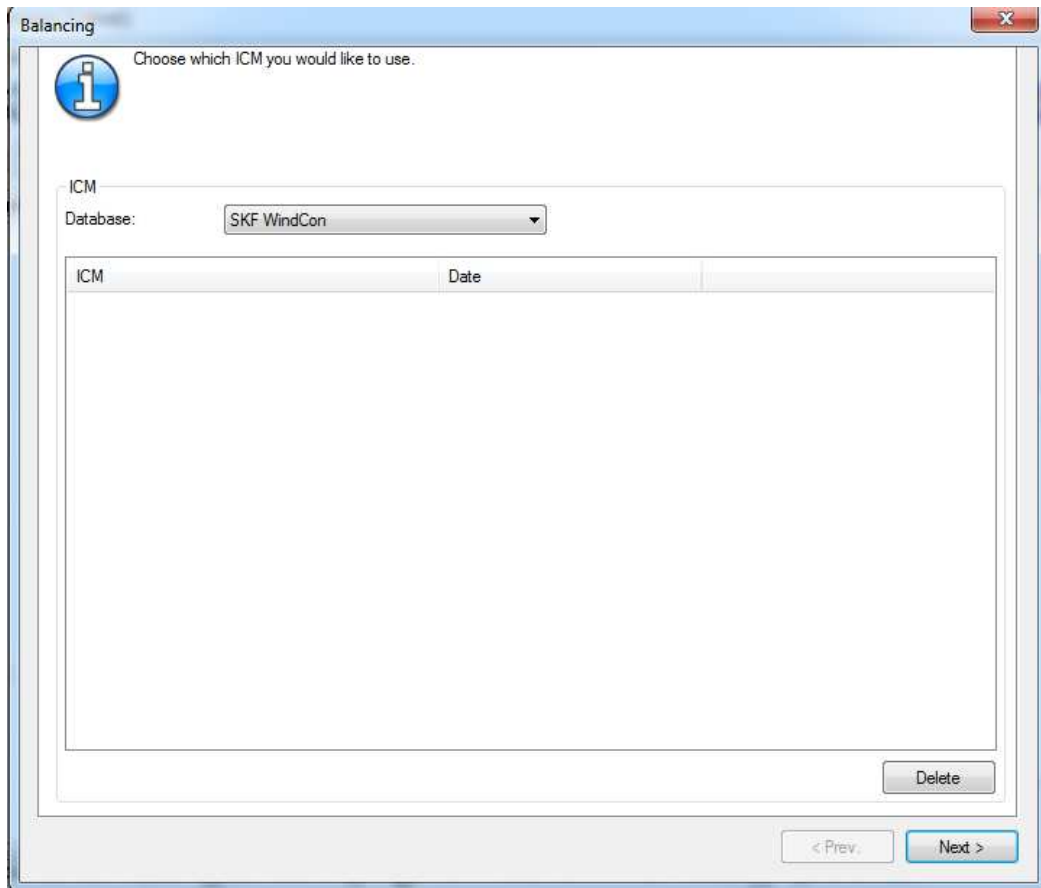

Figure 6 - 71.
Example of Select an ICM for Balancing Analysis.

Step 2: Choose which points, planes and states that this balance should use. For big machines such as a turbine, it is possible to balance a few of the planes. It is not necessary to balance all the planes, all the time.

Step 3: Choose a measurement point to increase the factor in the calculation. The higher number yields the greater factor in the calculation.

Step 4: Choose the data to use, to eliminate unbalance.

Live data display all the measurement points with an amplitude, phase and number of means collected. A phase % is the difference between highest and lowest and calculated over 360 degrees. Between 0 and 5% is a normal range, whereas 5 to 10% is unstable and greater than 10% is an unusable phase. If the phase is unusable, the balancing is most likely going to fail. In such case, go back and perform a normal analysis of the machine and determine what the problem is and remove the problem first. A large number of test weights can also cause an unusable phase.

Step 5: After all the possible combinations have been calculated and optimised, a balancing result is available.

The improvement shows how much of the vibration has been eliminated. The biggest value is 100%.

In order to minimise the mounting weight, one of the combinations may have lesser weight than the others. It is also possible to input own weights to calculate

expected deflection. This can be used if there is any plane that could not be mounted for some reason or maybe the weights used don't correspond exactly to the recommendations.

After weights are mounted, it is strongly recommended to go back to the eliminating screen (step 4) and collect some new live data. It is most likely that the elimination of unbalance can continue, in an iterative manner, until only a very small unbalance is left.

ICM

ICM (influence coefficient matrix) interface allows a user to create an ICM for the selected database. Created ICMs are used for further on-line balancing.

Follow the steps below in order to create an ICM.

Step 1: Choose sensors, number of planes and number of states from the machine of the selected database.

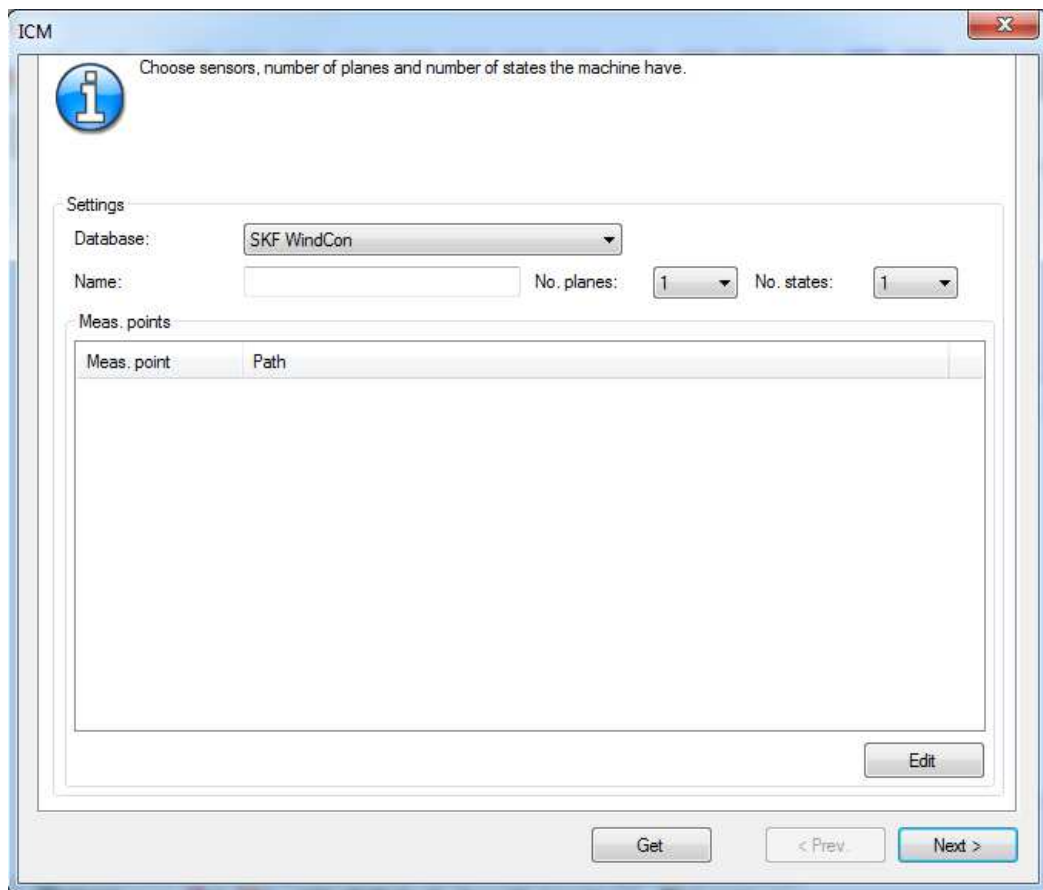

Figure 6 - 72.
Example of Create an ICM Settings.

Database is the database to which this ICM applies.

Name is the text reference to the ICM.

No. planes is the number of locations that weights can be added.

No. states is the number of defined speed ranges in which a balancing is conducted. For large turbines, it could be more than one. Whereas for regular fans, it probably would be one.

Point is the selected harmonic measurement point.

Path is the particular harmonic measurement point's path.

Edit brings up the hierarchy view. Select a harmonic measurement point by checking a box.

Get lists the existing ICMs of the selected database from which an ICM can be selected.

Next continues to the next screen (step 2).

Step 2: Name the planes, states and define balancing speed range by a centre frequency with a plus/minus delta speed.

Step 3: Now it is time to select data. Data can be collected live as well as read from the database. It is important to input weight and phase of every test weight used.

Step 4: At this stage, verify that the amplitudes or phase has changed between initial run and the test runs. It is possible to see the actual number of mean values collected. If the changes in amplitude and phase were too small, then probably the test weights were too light. This can cause an incorrect ICM which in turn is inappropriate to use for a good balancing.

Step 5: Presentation of the ICM matrix over every defined state is shown. Note that the matrix condition number should not be greater than 4.

Event Log

Event log is available for IMx-R devices only.

It displays all the events of the selected device type (DAD) of the specified database. For detailed information, refer to IMx-R User Manual for IMx-R devices.

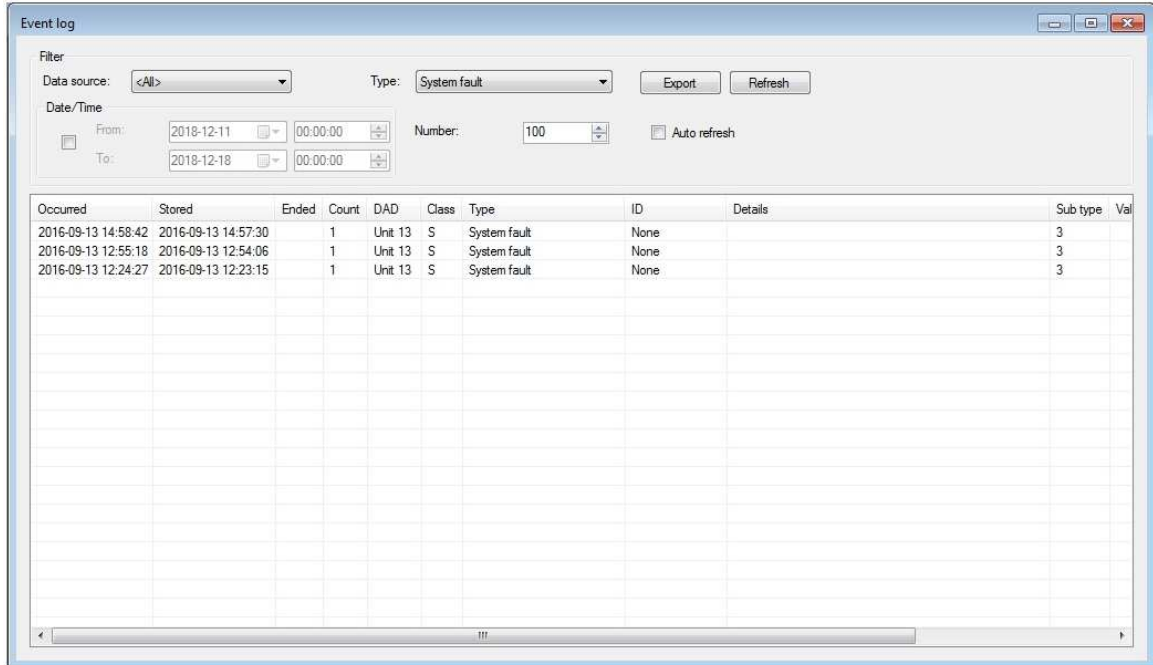

The screenshot shows the 'Event log' window with a filter set to 'System fault'. The table below displays the log entries:

Occurred	Stored	Ended	Count	DAD	Class	Type	ID	Details	Sub type	Val
2016-09-13 14:58:42	2016-09-13 14:57:30		1	Unit 13	S	System fault	None		3	
2016-09-13 12:55:18	2016-09-13 12:54:06		1	Unit 13	S	System fault	None		3	
2016-09-13 12:24:27	2016-09-13 12:23:15		1	Unit 13	S	System fault	None		3	

Figure 6 - 73.
Example of Event Log.

Class: S = CM system fault

A = alarm

If **Auto refresh** is enabled, the event log will be refreshed according to the value set for [Event Log refresh rate](#) in User Preferences.

Portables

Portables menu provides the following interfaces.

- Microlog Analyzer
- [Coded notes](#)

Microlog Analyzer

The Microlog Analyzer interface has four tabs where users can apply different actions. Upon opening the interface, @ptitude Observer automatically tries to get the status of the connected Microlog Analyzer.

Status

This shows information retrieved from the Microlog Analyzer, such as firmware version, current date/time, total number of points stored currently, total amount of free memory, temperature inside the device and battery voltage.

Status retrieves the status from the connected Microlog Analyzer.

Clear removes all routes and data from the memory of the connected Microlog Analyzer.

Reset deletes all the data from the existing routes on the connected Microlog Analyzer. For Microlog Analyzer USB communication only, the clock is set to the PC internal clock.

Download

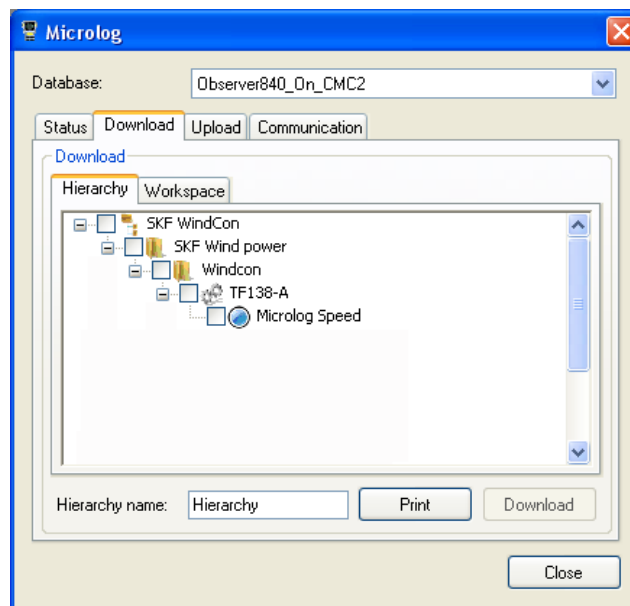

Figure 6 - 74.

Example of @ptitude Observer Download Routes to Microlog Analyzer.

This is used to download routes to the Microlog Analyzer. It is possible to download a section of the hierarchy as a route or a workspace as a route.

Hierarchy name specifies a custom name for the route that will be assigned when the selected portion of the hierarchy is downloaded to the Microlog Analyzer. It is available for the hierarchy setting only.

Print prints the selected hierarchy or workspace as a route list.

Download starts the download to the Microlog Analyzer.

Upload

The upload setting is used to transfer the data collected by the Microlog Analyzer and save it in the @ptitude Observer database.

Non route enables the upload of data that is not route-based. Non-route is also known as brute force.

Upload measurement history uploads the history of measurement points for USB communication only.

Reset deletes all data on the specified route, but keeps the route information so the route can be measured again.

Remove deletes the specified route and all data on the route. To use the route again, it must be downloaded again to the Microlog Analyzer.

Upload uploads the selected route and stores the data in the @ptitude Observer database.

Communication

The communication settings change the settings used to communicate with the Microlog Analyzer. These settings will be saved until the next time communication settings, is opened.

Type can be USB or Serial.

Port is required for the serial type only. It specifies which port to use for serial communication.

Baud rate is also required for the serial type only. It specifies which speed to use for serial communication. The default is 115200.

Coded Notes

Coded notes interface configures the coded notes that should be sent to the Microlog Analyzer device when downloading routes. A coded note is a pre-configured comment to apply to a certain measurement.

Window

Window menu item provides the following interfaces.

- [Cascade](#)
- [Tile Vertically](#)
- [Tile Horizontally](#)
- [Close all](#)

Cascade

Cascade interface organises all opened windows in a cascade.

Tile Vertically

Tile vertically interface arranges all opened windows vertically.

Tile Horizontally

Tile Horizontally interface arranges all opened windows horizontally.

Close All

Close closes all the opened windows.

Help

Help menu provides the following interfaces.

- [Contents \(F1\)](#)
- [Search](#)
- [Enter new license key](#)
- [News in Observer](#)
- [SKF Online Repository](#)
- [SKF CMC Homepage](#)
- [SKF Reliability Forum](#)
- [About](#)

Contents

Contents interface opens the help file for @ptitude Observer.

Search

Search interface opens the @ptitude Observer help file in search mode.

Enter New License Key

A new license key is required if a new upgrade to the @ptitude Observer service suite has been purchased. The software must be restarted after the registration. Refer to [Getting Started](#).

News in Observer

News in Observer contains information on the new features in the currently released version.

SKF Online Repository

Through the SKF Online Repository (SKF OR) it is possible to share application logic and system design with other @ptitude Observer users.

Currently it is possible to share bearing information, machine templates, data miner views and custom diagnosis rules.

When adding a new bearing to the system, it is possible to share this bearing information to other Observer users. After the submission has been approved, other users will automatically receive a notification the next time they start @ptitude Observer that a new bearing is available and they can choose to automatically install in their bearing database.

The same logic applies to machine templates, data miner views and custom diagnosis rules.

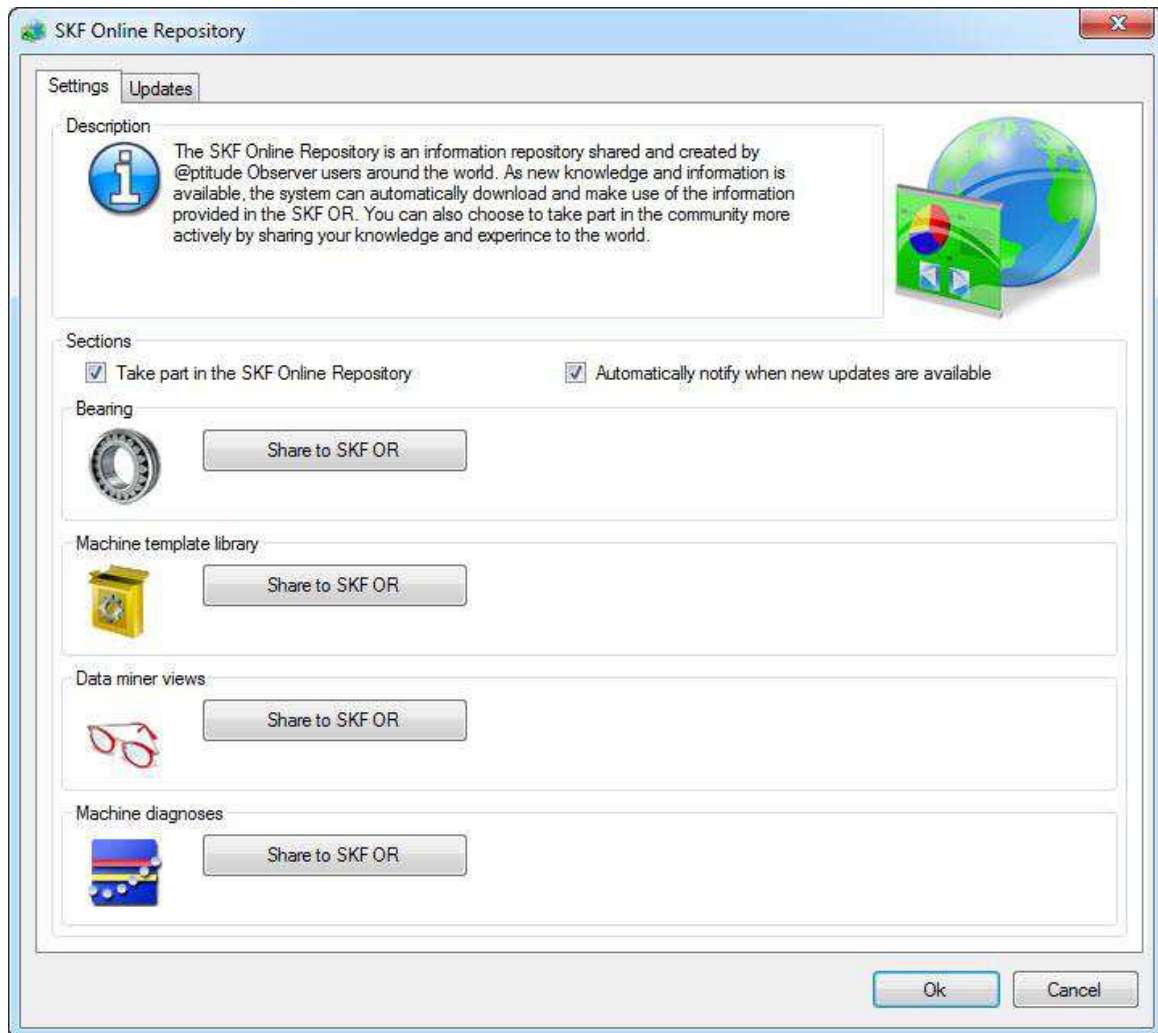

Figure 6 - 75.
Example of @ptitude Observer SKF Online Repository Settings.

Take part in the SKF Online Repository configures the system to be able to send and receive data from the SKF OR, if checked.

Automatically notify when new updates are available enables the system to automatically check the SKF OR for any new updates available when the @ptitude Observer system starts.

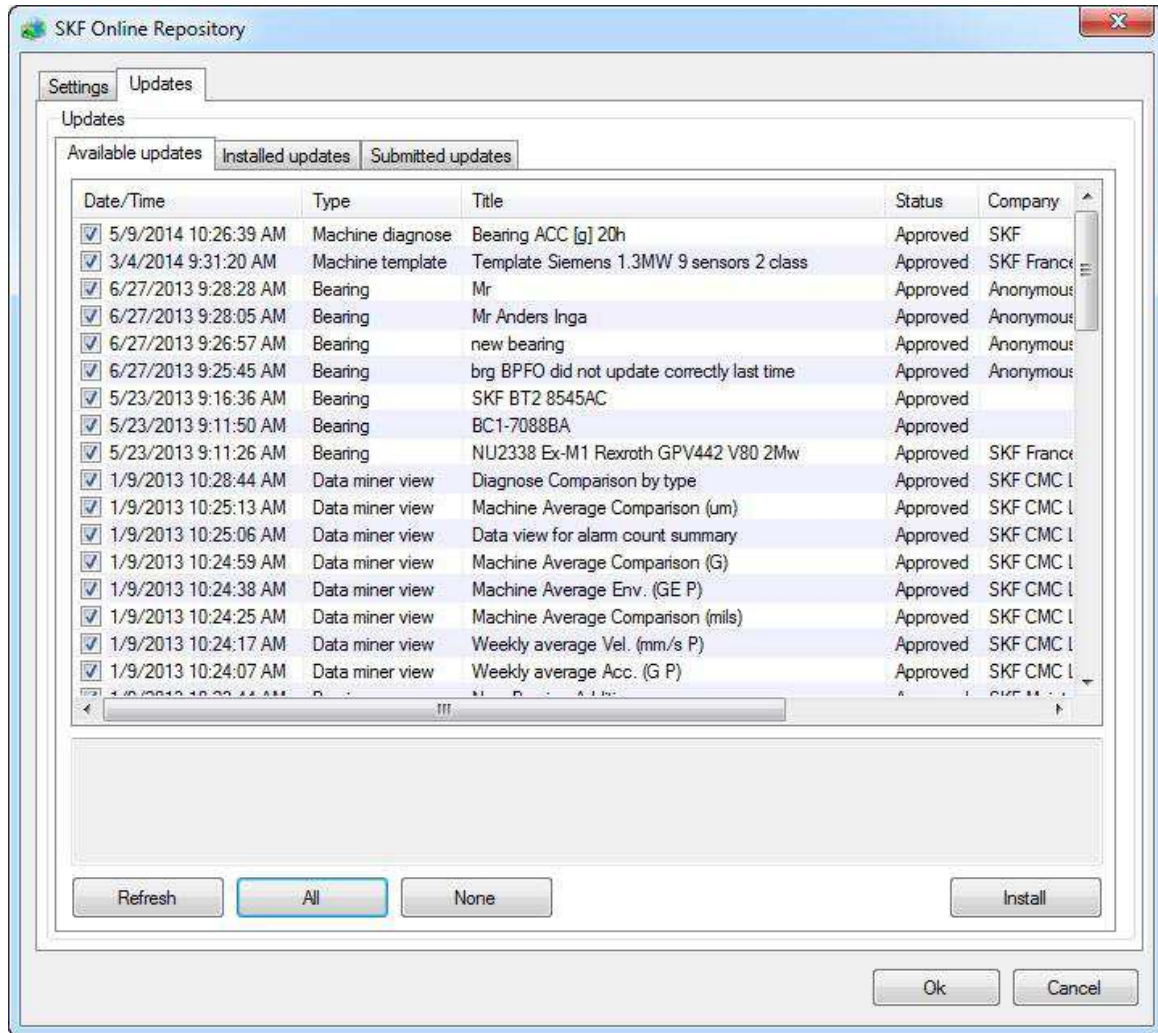

Figure 6 - 76.
Example of @ptitude Observer SKF OR Updates.

Available updates are updates that are available but have not been downloaded and installed yet.

Installed updates are updates that have been installed through the SKF OR.

Submitted updates are updates that have been submitted but not yet approved.

SKF CMC Homepage

This interface starts the default web browser on the local computer and navigates to SKF Condition Monitoring product information.

SKF Reliability Forum

This interface starts the default web browser on the local computer and navigates to the SKF Reliability forum. A username and password is needed to access the forum.

About

This interface displays version information about the currently installed version of SKF @ptitude Observer.

About @ptitude Observer displays the **System Info** box which lists all the modules that are enabled by the license key (that is, currently installed in the Observer application). Use the scroll bar to view the list.

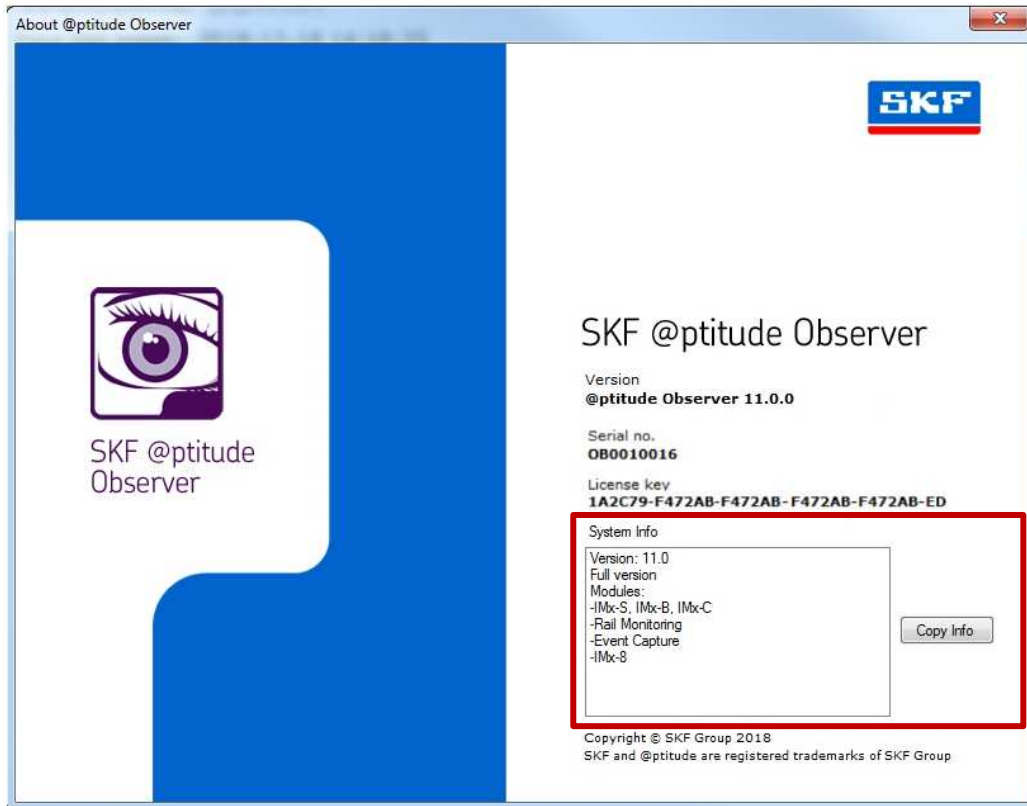

Figure 6 - 77.
System Info and Copy Info.

This list cannot be edited but it can be copied.

- Click **Copy Info** to copy the contents of the System Info box to the clipboard.
- Paste the contents into an email or other document to keep a record of the licenced modules or to request additional modules.

Appendix A

What to Expect When Using Event Capture

This appendix describes the behaviour of the event capture function under various conditions.

- The manual capture function is not included in the count of maximum event captures stored per day. A manual event capture is stored even if the limit of event captures per day is reached.

Event Capture after an IMx Reboot

There is a minimum 60 second event capture disarm period between an IMx reboot and an event capture triggered by an event capture point in alarm or a manual event capture. During this start-up period, alarm events will not initiate a new event capture. This disarm period is a firmware characteristic that allows the system to avoid unwanted captures at start-up when being in alarm before reconfiguration.

- For example: If a new alarm occurs on an event capture point 30 seconds after an IMx reboot, an event capture will not start. There might, however, be an entry in the alarm list for this alarm.

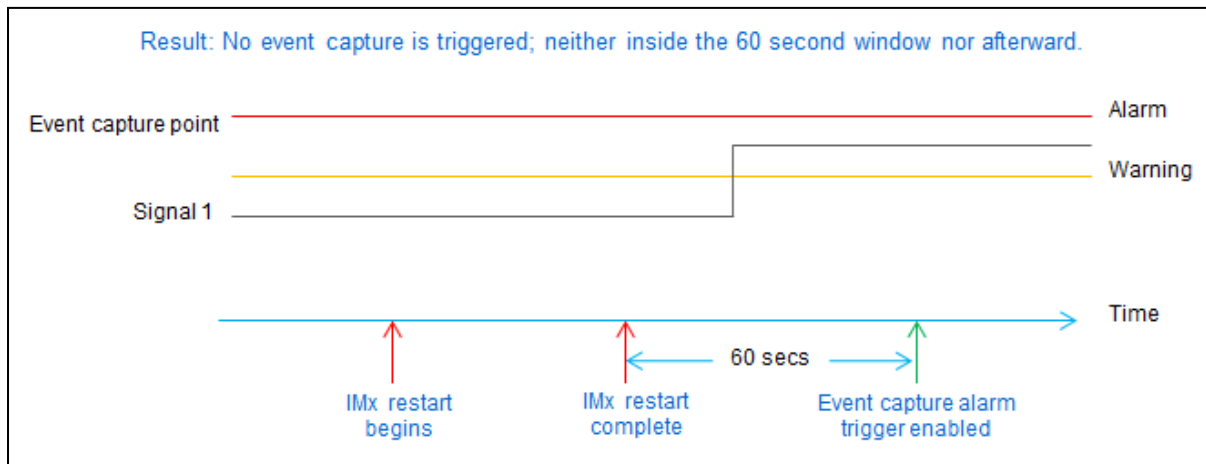

Figure A - 1.
No Event Capture Is Triggered.

- The pre-data buffer starts filling after the IMx device reboot process is complete.
- A manual capture can be triggered within the disarm time.

Depending on when the alarm is triggered and the time specified for pre-data, an event capture may contain only the alarm segment and less than expected pre-data.

Incomplete Pre and Post Data

In normal operation, a completed event capture will have pre-and post-data lengths as specified in the event capture group properties. However, under some conditions the capture of pre-data or post-data may be incomplete.

Incomplete Pre Data

If the IMx device did not have sufficient time to fill the pre-data buffer before the event capture is triggered, the captured pre-data returned may have a length less than that specified in the event capture group.

Possible conditions where this might occur include:

- A manual capture is initiated in a time shorter than the pre-data length after another event capture has been completely uploaded.

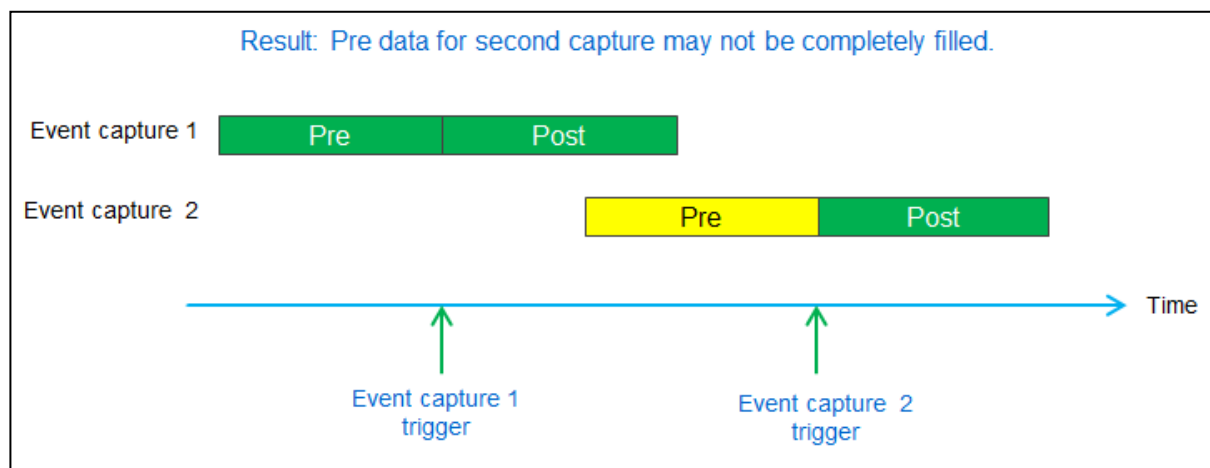

Figure A - 2.
Example of Incomplete Pre-Data.

- An alarm driven capture is initiated within a time shorter than the pre-data length after another event capture has been completed.
- An event capture is initiated after an IMx reboot within a shorter time than the pre-data length.

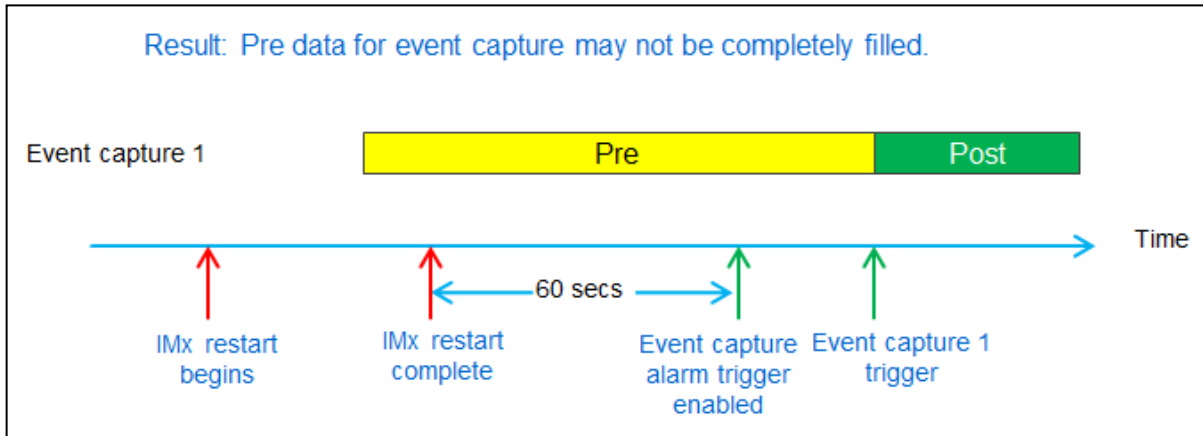

Figure A - 3.
Event Capture Triggered Within a Time Shorter than the Pre-Data.

Incomplete Post Data

The captured post data returned may have a length less than that specified in the event capture group.

Reasons for the early termination of post data include the following:

- Loss of power to the IMx
- Manual reset by command (**Restart** on the **IMx/MasCon devices** configuration tool)
- Firmware update
- Watchdog reset due to firmware/hardware problem
- System config update (for example, changing device number or network settings)
- Large negative time adjustment (synchronization was not done for weeks or months)

Two results are possible when post data is incomplete.

Power was lost before the alarm containing the event trigger was saved to non-volatile memory.

The Monitor service will never see either the alarm or the end of the event capture and therefore any captured data already received has little value. When closed, the incomplete event capture shows in the event capture list, but no plots are available.

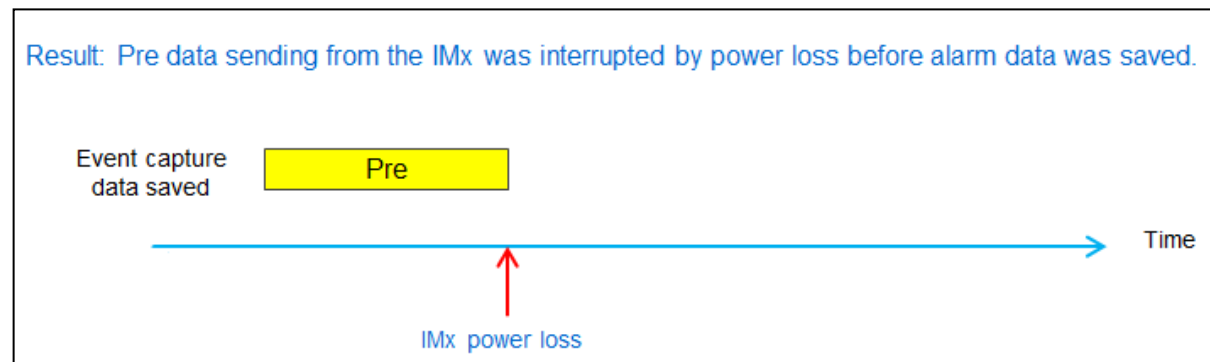

Figure A - 4.
Event Capture Interrupted Before the Alarm Is Saved.

- If all channels in the capture are missing the alarm data, then the incomplete event capture entry is displayed with the Transfer status Truncated, but no plots are available.
- If one or more event capture points received a captured alarm while other points in the group did not, only limited, partial data will be visible. Because the display depends on the presence of the alarm to function correctly, many features of the event capture plots will not be fully functional.
 - Channels with alarms will display whatever data was provided from the capture process.
 - Channels without an alarm will not display captured data fully. There will be no band marker in the full time waveform plot, the zoomed time waveform plot will show only a big “X” and the spectrum plot data will not cover the normal zoomed in region of the time waveform.

Power was lost after the alarm data was committed to non-volatile memory

The alarm data will be sent by the IMx once power is restored, but the end data was not saved and will never be received by the Monitor service. When closed, this incomplete event capture entry will be visible and it can be opened for display even though some post data will be missing.

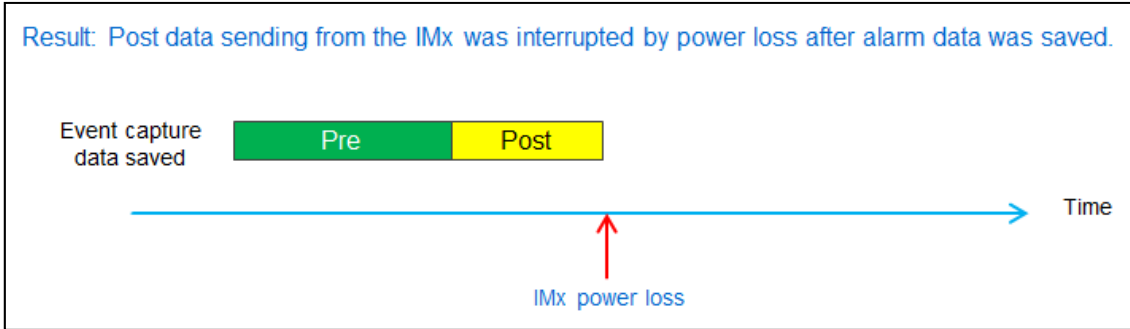

Figure A - 5.
Event Capture Interrupted After the Alarm Is Saved.

Active Range

If an event capture is started inside an active range and then goes outside the range while the event capture is ongoing, the data will be collected as usual.

If event capture points are in an alarm group and outside active range of the event capture group and another member of the alarm group goes in alarm, the event capture is also stored.

If an IMx device restarts because of reconfiguration during an ongoing event capture, the IMx device will continue sending event capture data until the remaining data has been stored in the non-volatile memory. Then, the device will reboot. After reboot, it will continue sending the remaining data from the interrupted event capture.

Network Interruptions During an Event Capture

If there is an interruption in network communication between the IMx device and the Monitor service during an ongoing event capture, the progress indicator in the Event Capture view window may stop updating and show no further progress.

The event capture will remain in a pending state until one of the following occurs:

- A new alarm-triggered event capture is received from the IMx device. In this case the pending event capture is closed and a new one is opened for the incoming alarm-based capture.
- Once the network problems are resolved, the previously interrupted event capture data transfer from the IMx is resumed and the event capture data transfer finishes normally.
- The pending event in the Event Capture view list is cancelled by the user.
 - While an event capture remains in a pending state on an IMx, no further manual event captures can be initiated on that IMx device.

Signals Outside Cable Fault Detection Thresholds

Event capture signal levels that are detected to be outside cable fault threshold levels will continue to be collected and stored in the event capture data.

- The cable fault threshold values used for determining the presence of cable fault issues are those currently stored for the individual IMx channels.

When viewing data in either the event capture time waveform plot or event capture 3D plot, where any captured measurements have been found to be outside cable fault threshold limits, a warning message is displayed in the plot indicating a possible problem with the data.

Miscellaneous

If the pre-data received is less than the total quantity of pre-data expected, the Transfer status in the Event Capture list is Done, Pre data not filled. This indicates that the Monitor has received all the data the IMx has available to send, but the pre-buffer was not filled when the event capture was triggered due to one of the reasons stated above.

Stopping the Monitor service and restarting it while an event capture is ongoing does not affect the storage of event capture data. The IMx will pick up the data after the Monitor service and the IMx device have reconnected.

The date in the alarm list for the first event capture point in alarm matches the event capture date and the 0 point in the event capture graph. Where there are several event capture points, some might have a slightly later date/time.

Ongoing event capture: IMx device restarts

The IMx device will continue sending event capture data until the remaining data is placed in the non-volatile memory, but then it will reboot. After reboot, the device will continue sending the remaining data from the interrupted event capture.

Manual event capture: Alarm event occurs

If a manual event capture is ongoing, the IMx event capture is locked, meaning that despite an alarm on the event capture point it will continue sending the manual event capture data.

If a manual capture is in progress it will finish and no other event capture is stored. However, if there is an alarm group in alarm, a second overlapped alarm event capture may be stored.

Alarm event capture: Change in alarm state

If an event capture starts with warning level and the amplitudes increase to alarm level while the event capture is ongoing, only one event capture is stored.

- The alarm list will display dual alarms for both warning and alarm states.

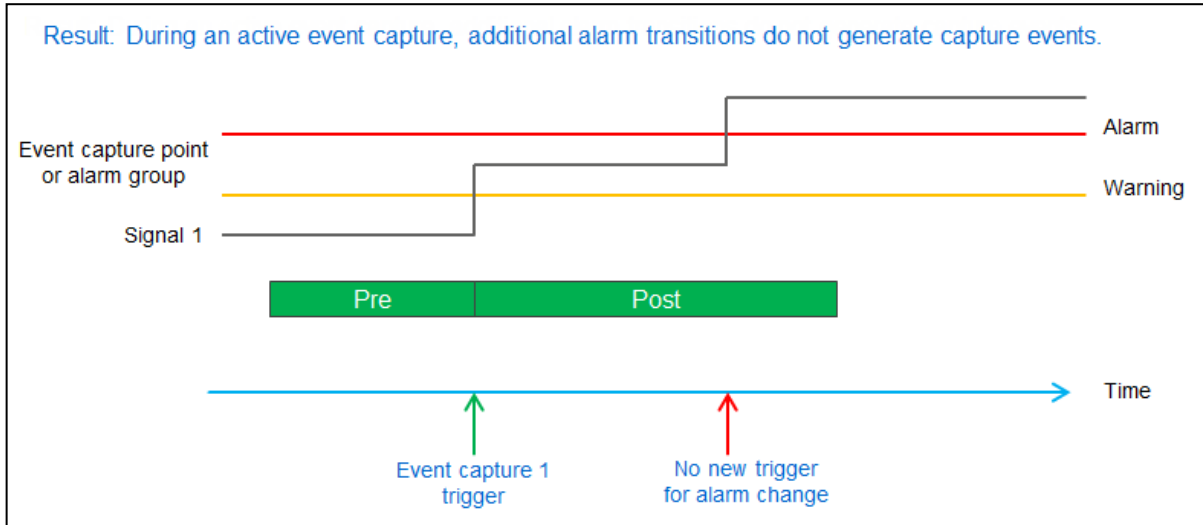

Figure A - 6.
Event Capture with Additional Alarm Transitions.

Cancel button

The **Cancel** button in the event capture window works as follows:

- Clicking the **Cancel** button stops the IMx device from sending event capture data by forcing a reset.
- Data received before the **Cancel** button is activated is retained.

Alarm leave time

The alarm leave time is calculated to satisfy both a minimum number of 10 measurements and a minimum time of approximately 60 seconds. This means that the IMx needs to see a minimum number of measurement values out of alarm state before enabling the setting of a new alarm state that corresponds to at least 60 seconds of time.

- A transition out of and back into warning state that happens in less time than the alarm leave time does not generate a new event capture.

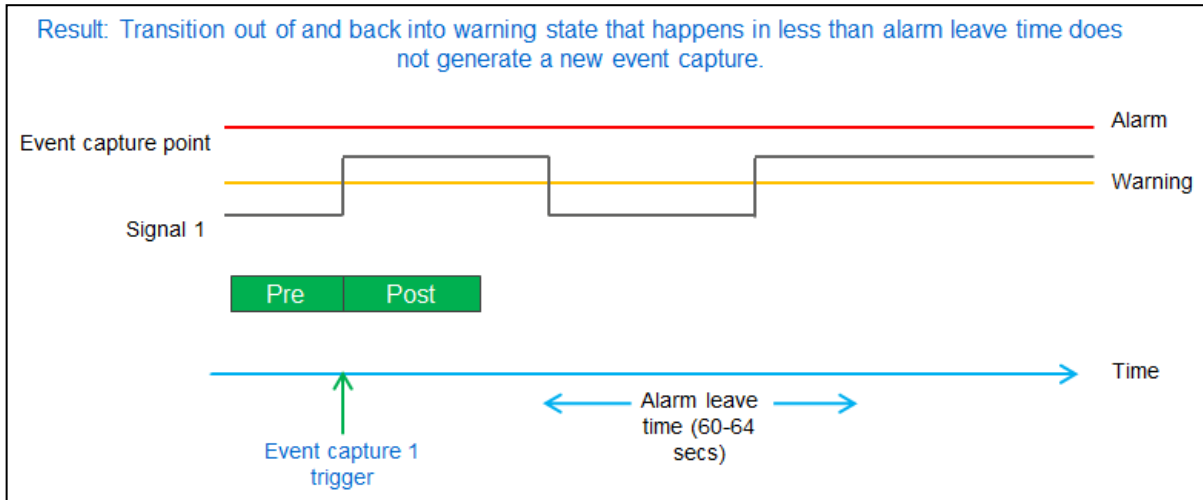

Figure A - 7.
Alarm Leave Time Shorter than Warning State Transition.

- A transition out of and back into warning state that happens in more time than the alarm leave time does generate a new event capture.

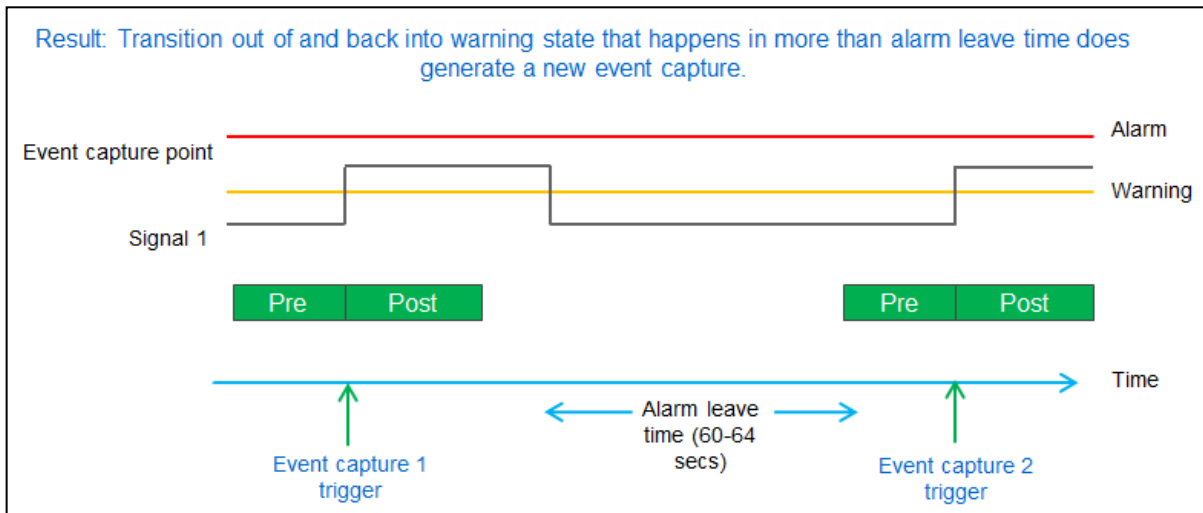

Figure A - 8.
Alarm Leave Time Longer than Warning State Transition.

No event capture is triggered when the alarm threshold is lowered to below the current vibration level.

Appendix B

Summary of Tools in the Toolbar

Observer Tools

The following images display @ptitude Observer's default toolbars and their toolbar button assignments, along with a brief description.

Primary Toolbar



Copy active window to clipboard - copies the active window to the clipboard. Can be pasted into another application.



Print active window - prints the window currently opened.



Notes – with a machine selected, opens a list of Notes related to the machine. Typical notes are maintenance activities and visual observations. Click New to open the Note dialog. Although a note is a machine-specific object, if an object of machine level or above is selected, then all notes under that object will be displayed. (See also Link to Hierarchy below.)



Event cases – with a machine selected, the tool opens the list of event cases for that machine. Event cases document reports, information and history regarding a specific event tied to a specific machine. Click **New** to open the **Edit Event Case** dialog. Although event cases are machine-specific, if an object of machine level or above is selected in the hierarchy, then all event case reports under that object will be displayed.



Attachments – with a machine selected, opens a list of related attachments. Click **New** to open the **Document** dialog to add a new attachment (a .PDF file, Word report or an MP3 file).



System alarm - opens the system alarm list for the selected hierarchy item. System alarms are raised for measurements out of range and system-related alarms such as defective sensors, cables, etc. The @ptitude Observer Monitor start-ups and any loss of contact between an IMx or MasCon device and Monitor are registered as well.



Alarm list - opens the alarm list for the selected hierarchy item and displays all the alarms under this item and sub-items in the alarm list.



Maintenance overview - opens the list of the maintenance tasks scheduled in the future.



Process overview - illustrates the current status of the machine through bars and process values. Upon opening a machine, all the measurement points on the machine are automatically added. At the top of process overview screen, there is a header displaying the total status of the process overview.



Machine parts – opens the machine parts tool for the creation of models of machines, including shafts, gear boxes, engines, fan casings, blades, generators, etc. The machine parts tool is used to calculate the disturbance frequencies specific to a particular machine, such as gear and bearing frequencies, etc., by using the defined machine data.



Maintenance planner - opens the **Maintenance Planner** dialog to configure maintenance tasks, such as lubrication, replacements, scheduled maintenance etc.



Data miner – opens the Data Miner dialog. Click **Add** to open the **Data Miner query editor** dialog to set the parameters for complex data mining from the Observer database. Results can be shown in three different formats: table, trend and bar.



Properties – with a machine selected in the hierarchy, opens the **Machine properties** dialog. With a measurement point selected, opens the **Meas. point** dialog.



Capture – with an event capture node selected in the hierarchy, launches the capture view. The capture view displays all points available in the capture. Each event capture point reflects a single channel. Two plot types are available:

- Event Capture Time Waveform - the true peak-peak is calculated from the time waveform.
- Event Capture 3D – shows spectrum graphs taken from successive measurement values in the selected continuous time waveform capture. The z-axis represents time intervals in the event capture from which spectrum graphs were generated.



Meas. Date – select a machine in the hierarchy, then select a measurement point and click the **Meas. date** tool. The interface lists the measurement dates of the selected measurement point.

Navigation Toolbar



Show tree view shows or hides the tree view window containing the hierarchy view, system view, workspace view and diagram view. Hiding the tree view window provides more area for plots on the screen.



Show bottom pane – with a plot in view, opens the bottom pane to show Machine parameters. Click the **Live** tool to begin updating the bottom pane with live data. Clicking the **Show bottom pane** tool again closes the bottom pane.



Link to hierarchy – click to turn **off** the link to the hierarchy. If a hyperlink is shown for the selected note in the Notes window, it can be opened by clicking the hyperlink. Then, the **Notes** window is automatically linked to the hierarchy. Therefore, selecting an item in the hierarchy updates the **Notes** window automatically with the notes of the newly selected object. Click this tool to turn off the link and prevent the **Notes** window from updating automatically. Instead, the **Notes** window will retain the information from the previous hierarchy item.



Show previous measurement point – with a measurement point selected in the hierarchy, moves the selection to the measurement point above it.



Show next measurement point – with a measurement point selected in the hierarchy, moves the selection to the measurement point below it.

Measurements Toolbar



Buffer –control and filter what data is retrieved from the database into the Meas. Date window. Specify date ranges, filter parameters and buffer types.



Refresh - forces the system to refresh (recreate) the hierarchy view, system view or workspace view.



Previous measurement - refreshes the graph with the data from the previous measurement.



Select measurement date – opens a calendar, select a date to see the measurements from that date. Double clicking on a date refreshes the graph with the data from the selected date.



Next measurement - refreshes the graph with the data from the next measurement.

Plots Toolbar



Spectra - shows the vibration amplitude as a function of frequency. Regardless of the input signal type, the amplitude can be shown in acceleration (m/s^2 or g), velocity (mm/s or ips) or displacement (μm or mils) using a linear or logarithmic amplitude scale.



Time waveform - shows the vibration against time. If the measurement on display is triggered using a digital input, the tachometer pulses are shown automatically to make it easier to track each revolution.



Phase - shows the phase with respect to the frequency. Combined with the amplitude spectrum, it is easy to get the phase lag for any peak in the vibration spectrum.



History - shows the variation in machine condition over time in order to identify impending machine faults. History display supports amplitude spectrum, phase spectrum and time waveform or any combination of those.



3D plot - generates a 3D/waterfall display of a selected measurement point or multiple selected points when available. 3D illustrates vibration spectra or envelopes as a function of time, shaft speed, power, temperature, torque or any other DC parameter.



Topology - shows the frequency versus the time or speed and the amplitude colour coded. This is useful to study transient data like run-ups or coast-downs. A topology plot is similar to a 3D plot, but the user is looking at the data from above.



Orbit - an orbit display is one of the best ways to analyse shaft movement. By combining phase and amplitude data from two sensors and plotting them together, it is possible to determine unbalance and alignment problems.



Profile - generates a profile display of a selected measurement point. Profile uses triggered acceleration time signal data to represent the out-of-roundness of any circular object. Examples of possible machines to use this feature are paper machine rollers and train wheels.



Gear inspector - generates a gear inspector display of a selected measurement point. Gear inspector is both a graphical display and an intuitive data gathering technique that helps detecting and visualizing the impact energy as a function of shaft/gear revolutions. It harnesses the best possible method of detecting this energy by using all channels in simultaneous data gathering mode.



Trend - shows any type of data, such as vibration amplitude/phase or process data, as a function of time, speed or other process data. In addition, trend displays spectra and notes flags in the plot shown as diamonds and circles, respectively.



Bode - shows any type of data, such as vibration amplitude/phase or process data, as a function of speed. A Bode plot is identical to that of trend display with the x-axis set to speed and phase visible.



Trend list - shows the raw trend data values in a tabular format.



Multi trend - generates a multi trend display of a selected measurement point or any other node type in the hierarchy view. Multi trend offers extended functionality to the normal trend plot because it is possible to overlay data from different measurement points or sources making it easier to compare data and distinguish if machines behave differently from each other. This display consists of two parts: a trend display and the bar display.



Diagnosis - opens the diagnosis display for the measurement point. All the different diagnoses attached to a measurement point are shown in the trend-type of display and calculated based on spectrum data stored in the database.



Protean - opens the Protean diagnosis display for the measurement point. All the different diagnoses attached to a measurement point are shown in the trend-type display and calculated based on spectrum data stored in the database. For more information refer to Appendix C, [Protean Diagnosis](#).



Polar - shows the vibration signal at 1, 2, 3 and 4 times the shaft speed in the complex domain. The vector is described with amplitude and phase. Polar display is often used to analyse run-ups and coast-downs, but is also useful in analysing steady state conditions as well.



Shaft centerline - shows the rotor position dynamically and is useful at run-up. Before the machine starts rotating, the shaft centerline display shows the shaft position to ensure that the shaft has an appropriate clearance at each bearing. When the shaft starts to rotate, the shaft position can be observed as the speed increases.



Combination plots - displays a list of available combination plots in the system. Combination plots show two or more types of diagrams for the same measurement. The following combination plots are available:

- Spectra/Phase
- Spectra/Time waveform
- Trend/Spectra - including an enhanced plot for spectral comparisons.
- Diagnosis/Spectra
- Diagnosis/Spectra/Time waveform – plot follows the cursor on the diagnosis plot and displays the simultaneous FFT and time waveform.
- Trend/Spectra/Time waveform - follows the cursor on the trend plot and displays the closest FFT and time waveform



Save Settings - saves any changes made to the graph settings, such as the scale settings.

Graph Display Toolbar



Fault frequencies - brings up a dialog for choosing machine parts from the machine that is currently being analysed. When one or more machine parts are selected, the frequencies for them are drawn in the graph.



Previous fault frequency - moves the active cursor to the previous machine part.



Next fault frequency - moves the active cursor to the next machine part.



DiagX - part of the system's built-in diagnostic system. Opens a dialog listing all the machine parts and the probability that the selected frequency including harmonics belong to a specific machine part.



Single cursor - adds a single cursor to the graph.



Band cursor - adds a band cursor to the graph. A band cursor has three handles at the top of the band.



Harmonics - produces a harmonic cursor of the currently selected frequency. Harmonic cursors can be set between 10 and 200 in User Preferences.



Sidebands - inserts a side band marker, marking 5 side bands below and 5 above an X marker.



Amplitude peaks – inserts a horizontal line stretching across the graph to indicate the highest peaks in the graph.



Clear – clears the graph of all tools.

Plot Tools Toolbar



Zoom - zooms in one click at a time; click again to zoom in closer.



Zoom out - returns a graph to its original size.



Delete - deletes a measurement from the database. Spectra, time waveform and phase are considered as a single measurement, which means that deleting a spectrum will also delete the corresponding time waveform and phase data, if there are any.



Save - saves the current live measurement from the graph to the database. The measurement will be marked with the storage reason “Manual”.



Live - reads data immediately from the measurement point(s) and displays it in the graph. To get live data, a connection to the @ptitude Observer Monitor computer must be established.

Appendix C

Protean Diagnosis

The Protean Diagnosis system

The Protean Diagnosis system is based on the earlier Machine Diagnostics solution implemented in SKF @ptitude Observer software. Below is a short description of the evolution of this solution.

Earlier Machine Diagnostics Solution

The Machine Diagnostics solution in SKF @ptitude Observer is comprised of the following main areas:

- Machine Parts – In this module the kinematics of the machine being monitored is described. All relevant defect frequencies are being calculated dynamically for each measurement based on the shaft speed measured simultaneously with the vibration data.
- Diagnosis Rules – For each defect a definition of how to calculate a Condition Indicator value is stored. A high-level user can define their own diagnosis rules.
- Diagnosis Trend – A series of Condition Indicator values coming from the processing of historical measurement data.
- Alarm level – A threshold level for the Condition Indicator that defines when an anomaly has been detected. This level is automatically calculated based on historical data and new data.

The Protean Diagnosis Solution

The Protean Diagnosis solution also uses the first 3 points shown in the list above together with some additional features:

- New capabilities in Condition Indicator calculation
- Dynamic alarm setting and smart triggering

A description of each feature follows.

Condition Indicator Calculation

In the Machine Diagnostics solution it is possible to calculate the Condition Indicator values by adding individual peaks of a frequency spectrum to form an RMS. It is also possible to calculate the Condition Indicator value as a percentage of Overall.

In the Protean solution it is also possible to calculate the Condition Indicator value as a percentage of a speed following band. Its main advantage is that the operating condition influences all peaks in a frequency range, including the ones detecting defects. By then calculating the Condition Indicator value as a percentage of a speed following band, (set to a range covering the peaks being used in the Condition Indicator calculation), this will substantially reduce the influence from the running condition of the machine.

Dynamic Threshold Setting

In the Machine Diagnostics solution it is possible to let the system set the alarm level based on the mean of a group of Condition Indicator values plus a user defined number of standard deviations above that mean. In the Protean solution a new threshold is being calculated automatically when an alarm has been triggered. If the Condition Indicator values decreases significantly the threshold is also recalculated. With this functionality the threshold is always set at a level to detect a significant increase of the Condition Indicator values.

Protean diagram example

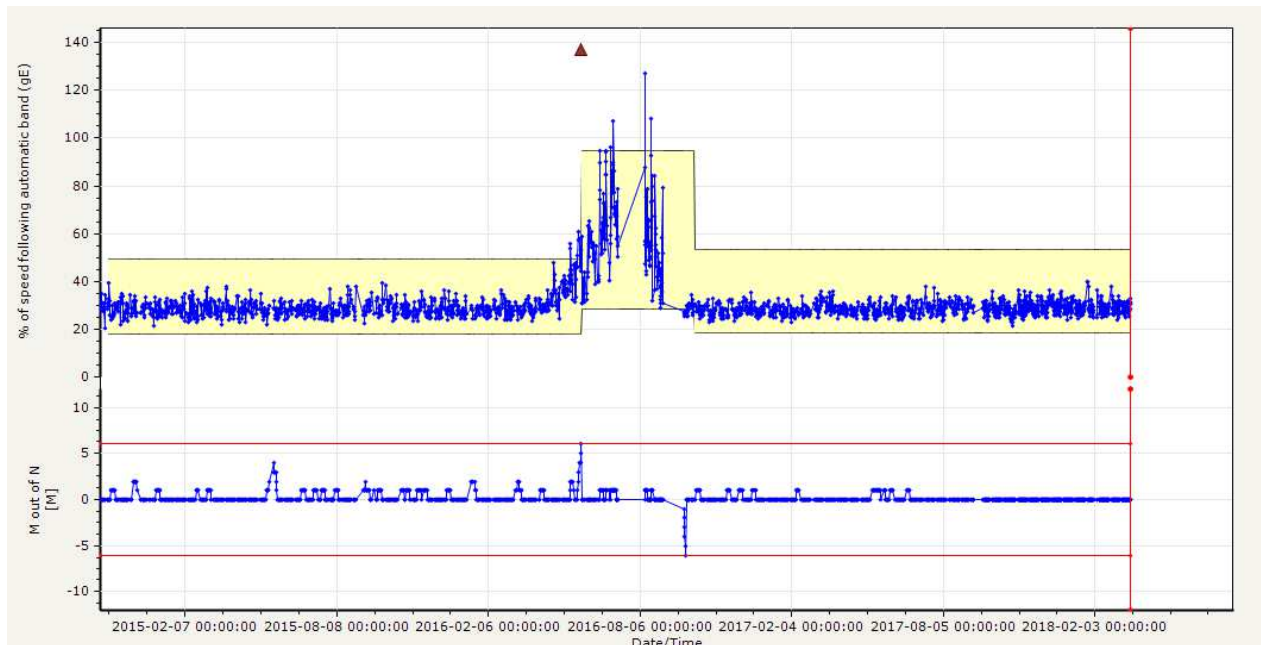

Figure C - 1.
Protean Diagnosis diagram showing a bearing defect

Appendix D

SKF Rail Track Monitoring

Introduction to SKF Rail Track Monitoring

SKF Rail Track Monitoring uses data from train mounted SKF Multilog IMx-Rail hardware to monitor the rail infrastructure. By gathering vibration data in this way, an analyst can review the track condition in @ptitude Observer software using various tools:

- Summary table – quickly identify track sections with highest severity events
- Scatter plot – section overview showing separate data for left and right rails
- Bubble graph – combining trend and severity information for a length of track
- Time waveform and spectrum – the vibration data collected from the track

For the purposes of evaluating the track condition and assigning a severity, the track is assessed in one metre sections (peak acceleration per metre). Based on such analyses, event cases and exceptions can be raised for investigation and corrective action. Such exceptions are notified to the operator/customer via a web app. This web app can be hosted on a local network or can be cloud based and provides:

- Line map – Google map with lines superimposed (colour coded for severity).
- Station dashboard – open exceptions grouped by Line, Station or direction
- Charts – access to any analysis outputs the analyst has attached

To support the analyst generated exception data and feedback on corrective action, the operator/customer can add details of visual inspections and actions taken in response to an exception.

Licensing

If the @ptitude Observer licence key does not include SKF Rail Track Monitoring then most functionality referred to here will not be visible to that user. This includes the RailMo tab (view), icons that are unique to rail track monitoring and RailMo sub-tabs. Security roles relating to rail track monitoring remain visible and active.

Terminology used

At a top level a database must be available (a database is usually company level). Within that database, on the Hierarchy tab, Trains (equivalent to Machines in a traditional @ptitude Observer system) can be created with suitable measurement points based on data gathered by appropriately configured IMx-Rail devices.

That Train data is then available for processing and analysis, based on the configuration of the dedicated RailMo tab (a dedicated database level tab like Hierarchy, System, Workspace etc.). This is used to define the railway network being monitored based on the following structure:

- Region
- Line

There can be multiple Lines within each Region and multiple regions within a Company. On adding a Line, two directions of travel are automatically created (initially named Bound 1 and Bound 2) and within these the sequential stations are defined.

During configuration of each station its location is defined by latitude, longitude, distance in metres from the previous station on this bound and a chainage value. (Chainage for any feature being its location along the network from a designated origin or zero point.)

Stations are joined by a Track section with a further identification of each Rail in a section:

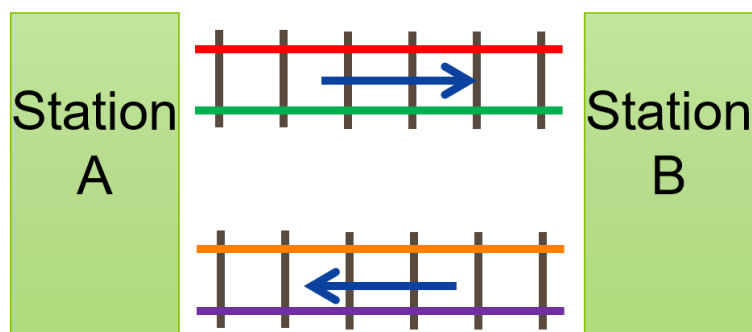

Figure D - 1.
Example of Rail identification

From Figure D - 1 above, if Station A is a southernmost station on a Line then travel from A to B may be termed 'Northbound'. On the northbound Track section there is a left and a right Rail. These are determined taking account of that direction of travel so red is left and green is right.

Considering the southbound case (B to A) the orange rail is now named right and purple is left.

Within track sections, features can be defined. A Track section Feature can, for example, be used to highlight the presence of a Turnout (points), Bridge, Tunnel, Turn or Another note or Other feature. Each feature is positionally defined by a chainage start and end, so if required, an allowance for higher expected acceleration levels due to the feature, can be made.

IMx requirements

For rail track monitoring an installed IMx-Rail device is required and within that, two analogue input channels and two digital channels need to be assigned.

- The analogue channels provide vibration data from the left and right rails.
- The digital channels are used to provide speed, an estimated distance travelled and direction of travel*.

*To provide direction of travel information the two tacho sensors must be slightly offset, circumferentially. For more information refer to the application note: CM3190 Detection of rotation direction of shaft in Observer.

Within @ptitude Observer, what would normally be regarded as a 'machine' is designated as a 'train' where the IMx and sensors are installed. Trains are defined with an assigned forward direction and train/sensor left and right are named relative to that direction:



Figure D - 2.
Example of train left and right

As shown diagrammatically in Figure D - 2 above, the left and right sensors should be mounted at the same position on the train, but on opposing sides. The blue arrow indicates the assigned forward direction; hence the red side/sensor is left and the green represents, right. See also [Add Trains](#).

@ptitude Observer measurement points

The focus here is to add configuration data for a train and associate this with an IMx-Rail device. Suitably configured, the IMx-Rail digital channels are used to provide speed channel data and to support a time difference point (used to infer the train's direction of travel).

The two vibration points are assigned as part of a Run cycle group, so that whilst the train is moving the vibration (sample level) data can be collected for rail condition analysis.

This level of @ptitude Observer configuration is equivalent to a 'machine' configuration and when completed together with an active, configured IMx-Rail the system can acquire data.

Rail track monitoring configuration

This describes the rail network and the infrastructure (Lines, Stations, Routes etc.), both in terms of their absolute (latitude and longitude) and relative locations (chainage and distance between stations). The data acquired at a train level is linked to the route configuration by a pattern matching technique:

The digital data from the IMx-Rail is used to estimate the distance travelled and this is matched to the infrastructure based on the data entered for station locations (specifically: the distance in metres from the previous station).

Once matched, the data is analysed and checked for anomalies that should be highlighted for corrective action (such as track inspection or replacement).

Rail track monitoring specific icons



Scatter plot – the [Scatter plot](#) icon is available in the plot toolbar.



Summary table – the Line [Summary table](#) icon is available in the plot toolbar.

The following icons are used in the RailMo tab to define the railway infrastructure:



Region



Line



Bound A



Bound B



Station



Track section



Incoming connection



Outgoing connection



Route

Configuring an IMx-Rail device

On-line Device Configurator

The SKF @ptitude Observer On-Line Device Configurator is a tool used to set the network configuration and identification of IMx hardware, including the IMx-Rail device. For more information, refer to the "On-line Device Configurator User Manual".

Device and channel configuration

Within the database to be used for rail track monitoring, create a device using ([Create Device](#)), from the IMx/MasCon Devices screen. In this case set the **Model** as IMx-Rail.

The IMx-Rail device will be added to the list of devices in the IMx/MasCon Devices screen. Once a network configuration file has been downloaded (and when the configured Monitor port is open for connection), the reported TCP State of the IMx-Rail device should be 'Connected'. (See Figure 4-6, [Creating IMx/MasCon Devices and Channels](#).)

Create Analogue Channels

Now select that device from the list of IMx/MasCon devices and then click **Create** below the Analogue Channels list ([Analogue Channels](#)).

Two analogue channels should be created to allow for measuring the vibration on the left and right side of the train. Both channels should be created by configuring the following fields:

- **Name** – Give an identifying name to the channel (Sensor Left or Right)
- **Sensor type** – Example: Acceleration [g]
- **Number** – Choose a free channel number
- **Cable check** – Configure as required
- **Sensitivity** – Set to the sensitivity of the sensor being used, example:10 mV/g

Create Digital Channels

Now select the device again and then click **Create** in the digital channels window ([Digital Channels](#)).

Two digital channels should be created to allow for the system to ascertain train speed and direction of travel.

Both channels should be created by configuring the following fields:

- **Number** – Choose a free channel number
- **Name** – Give an identifying name to the digital channel
- **Pulses/rev** – Specify the number of pulses per rev

IMx Firmware

IMx firmware is not installed during the @ptitude Observer software installation, so if necessary add or update to the latest available [Firmware](#).

Configuring @ptitude Observer for rail track monitoring

Introduction to @ptitude Observer configuration

There are several associated, but separate configuration steps required to complete a rail track monitoring, system configuration and to define the railway network being monitored:

- For the database
 - Set an appropriate Trend buffer size
 - Configure Peak Severity settings (if change from default is needed)

- Configure storage limitations
- On the Hierarchy tab:
 - Add Trains with the necessary measurement points and run cycle group
- On the RailMo tab:
 - Add Region, Line, Route structures (with Stations and Features)
 - Add Routes

Trend (rolling) buffer size

From the **Options** interface, select the appropriate database from the drop-down list and select the **Data** tab. There is a setting for the **Trend rolling buffer size**, which has a default size of 3 000 values, (see [Data Tab](#)).

The value should be changed to 32 000 000. This number is arrived at based on storing one year of speed signal values when the speed is sampled once every second. ($60 \times 60 \times 24 \times 365 = 31536000$). Increasing this value as indicated allows the software to reprocess speed data, when/if needed.

Peak severity settings and storage limitations

From the **Options** interface, select the appropriate database from the drop-down list and select the **RailMo** tab. There are settings associated with the Peak severity assessment and below that Storage limitations:

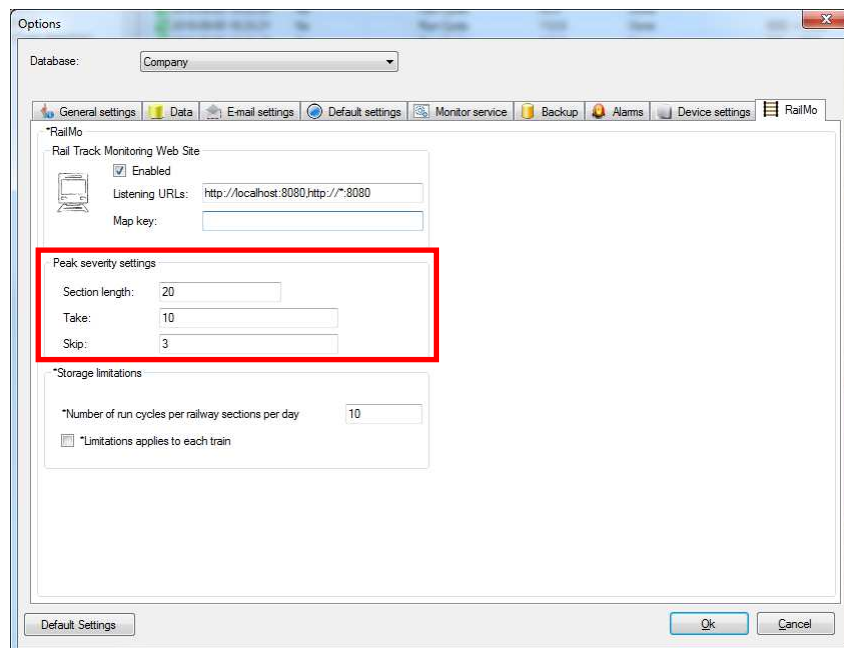

Figure D - 3.
Peak severity settings

Peak severity settings are based on a **Section length**, **Take** and **Skip** values. They are used, in conjunction with a date range, in the [Summary table](#) display.

For each metre of track, the most recent '**Take**' severity values are collected and sorted and then the '**Skip**' highest results are discarded. The highest remaining severity value becomes the severity value for that metre of track. Note that:

- If the number of available measurements in the date range is lower than '**Take**', the analysis will use what data is available.
- If the number of available measurements in the date range is lower than '**Skip**' (or if '**Skip**' is not lower than '**Take**') the severity will default to 0 (OK, green).

The **Section length** setting determines how many metres of track, the track sections should be divided into. For every 'x' metre, the highest of the calculated severities (or alarm levels) is used. In the summary table display, each entry is colour coded with the highest severity remaining after this **Take** and **Skip**, processing.

Storage limitations are configurable and will limit the number of run cycles processed per track section, per day. This includes an option to apply this limit per train. No data is deleted, this limit affects only the processing of the run cycle data.

Add Trains

Trains are defined with an assigned forward direction even though the physical train may not have a uniquely identifiable front or rear.

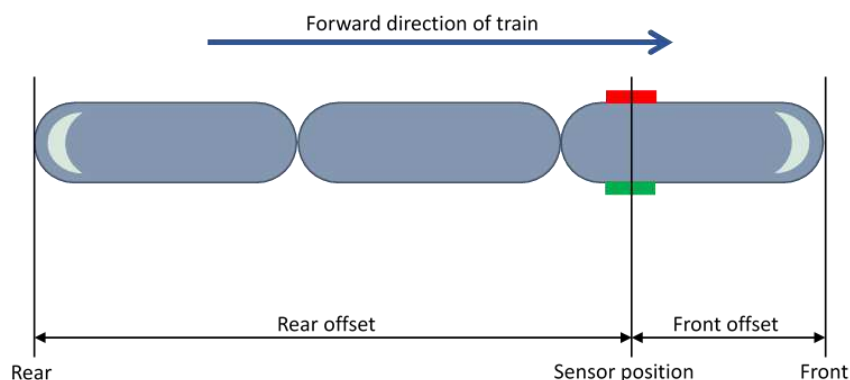

Figure D - 4.
Example of train and sensor definition

As shown diagrammatically in Figure D - 4 above, the left and right sensors should be mounted at the same position on the train, but on opposing sides. In this example, the blue arrow indicates the assigned forward direction; hence the red side/sensor is left and the green represents, right. The front and rear (sensor) offset measurements will also be required when adding the train to @ptitude Observer.

A train (with associated measurement points) is added to @ptitude Observer as a **Machine** (see [Machine](#)). On opening the dialog for Machine properties, first enter an appropriate name in the **General** tab and then select the **RailMo** tab. There, to configure a 'Machine' as a Train:

- Check **"Is train"**
- **Wheel diameter** – Diameter of the wheel (that the speed sensors are monitoring)
- **Front and Rear offset** – Distance from the vibration sensors to the front and rear of the train
- **Distance error threshold** – Threshold used in pattern recognition*
- **Alarms** – Alarm levels used for graphs. Note that **Critical level** is only used for the summary table and web interface

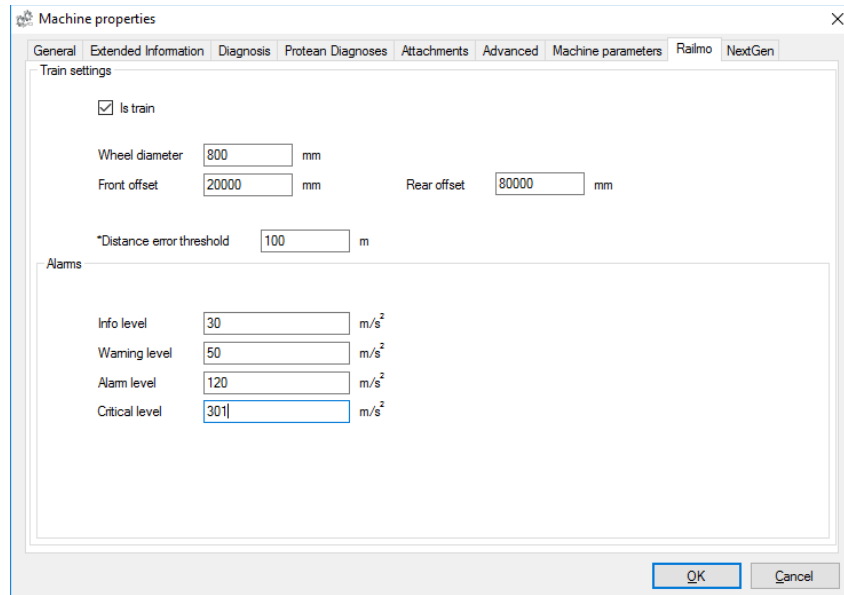

Figure D - 5.
Machine properties – RailMo tab

Data collection (IMx-Rail to a machine/train within the @ptitude Observer database) is independent of the rail track monitoring (Line/Station/Route) configuration. A pattern recognition technique is used to match collected data to track sections. Whilst data will be collected for all journeys, the analysis of that data can be limited, refer [Peak severity settings and storage limitations](#).

*The distance error threshold level is the total (allowed) error in pattern matches for 4 consecutive track sections. If the error when comparing the estimated distance (from IMx speed channel input) to actual (from Station configuration) is less than this threshold then a match is allowed. This value might have to be changed depending on the distances involved and variances in the estimated lengths of train runs, between stations.

Create measurement points

A measurement point defines a measurement that should be captured on a machine/train (see [Measurement Point](#)).

A train must be configured with a set of measurement points, as follows:

- Two, speed points (speed data from the two digital inputs)
- One, time difference point (direction of travel from the two digital inputs)
- Two, vibration points (the left and right rail, vibration measurements)

The process is generally as described in [Setting up Measurement Points and Alarms](#), though in addition, the vibration points belong to a run cycle group that is triggered by the train speed data.

Create speed points

Setup two speed points, choosing the appropriate IMx-Rail unit for the **Device** and speed channel, for **Channel**:

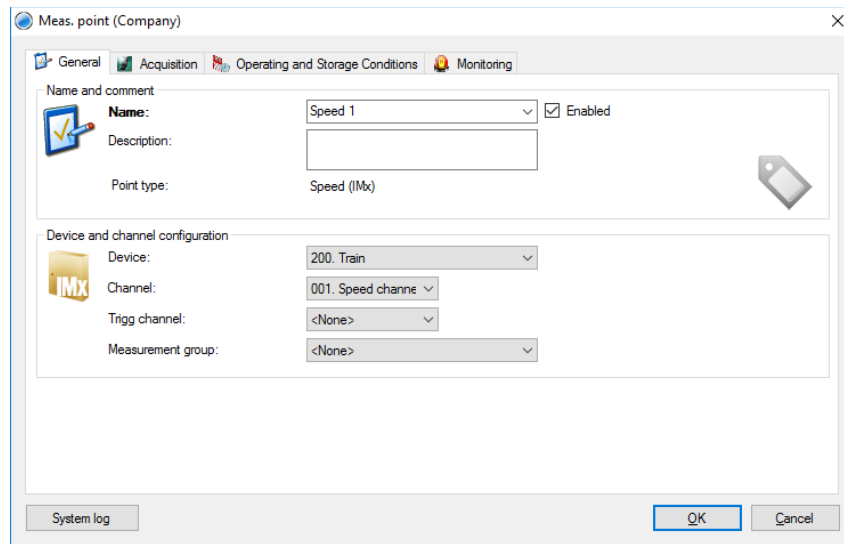

Figure D - 6.
IMx-Rail speed point

For one of the speed points, enable and configure the **Scheduled Trend storage** settings on the **Operating and Storage Conditions** tab, as follows:

- Check “**Enabled**”
- Enter 0.01667 (minutes) for the **Interval** and **Interval Alarm**. This recommended setting equates to a sample per second.

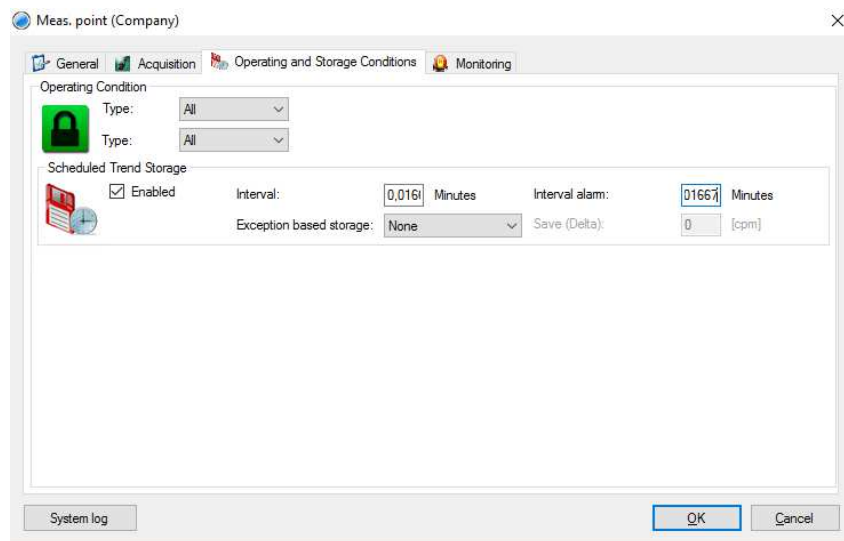

Figure D - 7.
One speed point: Scheduled Trend Storage settings

For the other speed point, disable **Scheduled Trend Storage** and for both speed points ensure that in the **Monitoring** tab, **Enable automatic alarms**, is not set.

Create a time difference point

Once the two speed points have been created, add a new measurement point, type: **Time difference**. Choose the appropriate IMx-Rail unit for the **Device** and the two speed channels for the **Channel** entries.

Enable and configure the **Scheduled Trend storage** settings on the **Operating and Storage Conditions** tab, as follows:

- Check “**Enabled**”
- Enter a value in minutes for the **Interval** and **Interval Alarm**

This point is assessing the direction of travel so a recommended minimum setting is 0.0833, which equates to a sample every 5 seconds. Longer time periods (less frequent checks) may be acceptable for train applications. Set both fields to the same value.

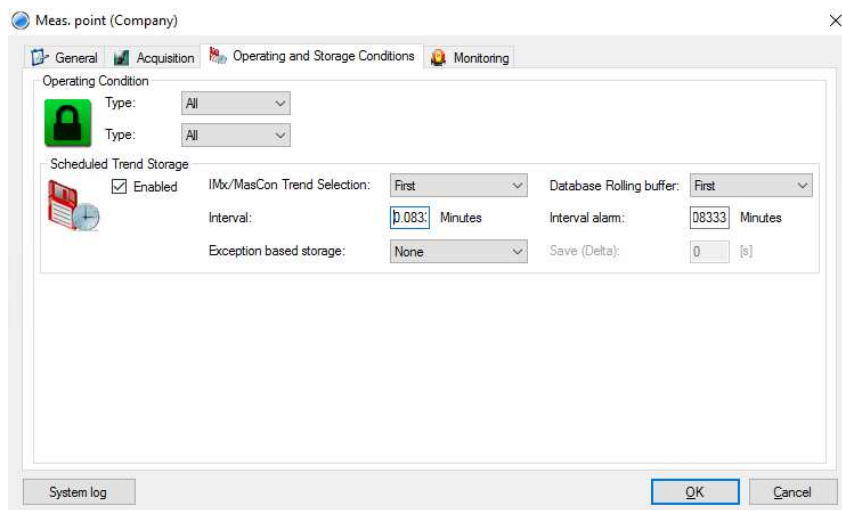

Figure D - 8.
Time difference point: Scheduled trend storage

As for the speed points ensure that in the **Monitoring** tab, **Enable automatic alarms**, is not set, for the Time difference point.

Run Cycle group

The Run Cycle group is used to control that the IMx-Rail (only) samples data whilst the train is moving. To start, add a run cycle group to the machine (train) by right clicking on it in the hierarchy and selecting the Run Cycle group option from the context menu.

When the **Capture Group** properties opens, on the **Common (General)** tab, give it an appropriate name and select the relevant IMx-Rail device from the **Device** drop-down.

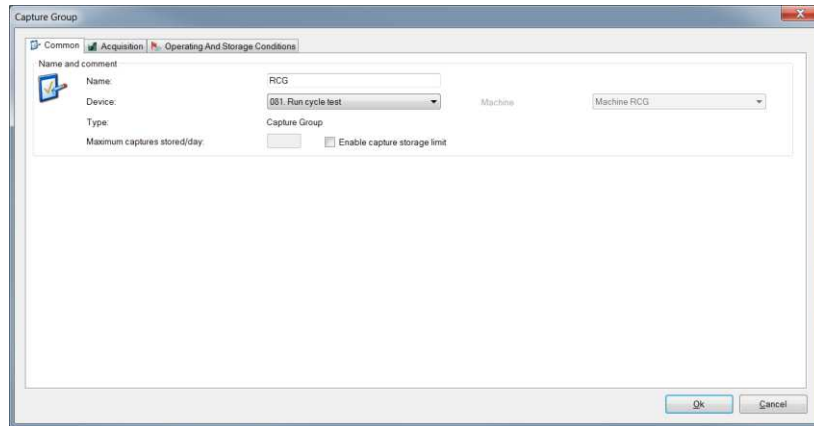

Figure D - 9.
Run cycle group – Common tab

Change to the **Acquisition** tab and select one of the two speed measurements as an associated measurement:

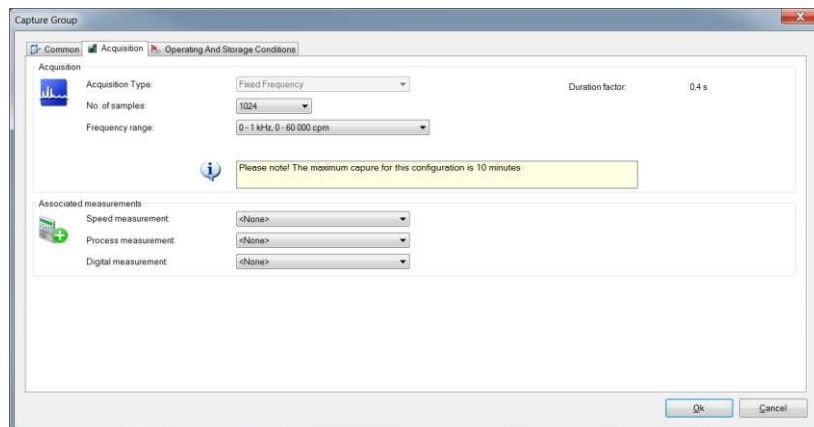

Figure D - 10.
Run cycle group – Acquisition tab

Note that the frequency range and number of samples dictate the maximum time available for a run cycle. Higher frequency range and greater number of samples reduce the maximum time available. As shown above, this information is displayed to the user.

No changes are needed in the **Operating and Storage** tab, click **OK** to save the run cycle group.

Create measurement points in the run cycle group

Finally, right click on the run cycle group to add measurement points, the Measurement point properties dialog opens:

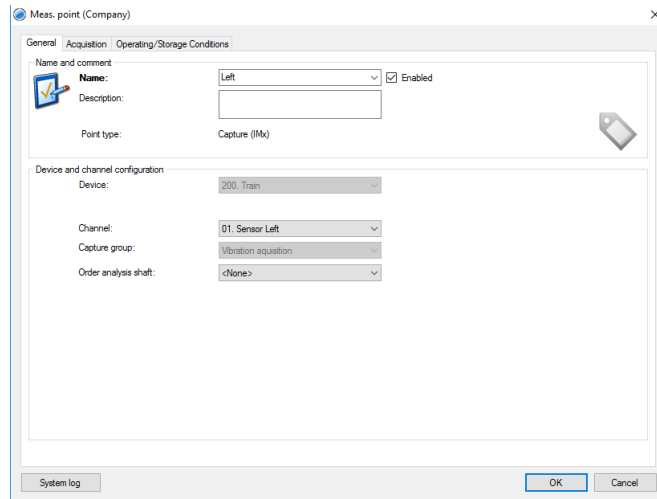

Figure D - 11.
Creating a vibration point

Create a measurement point for each of the two vibration channels on the IMx-Rail.

Important note: When naming these points, the use of “Left” and “Right” as point names is mandatory as the system will actively use this naming to determine if the data is arriving from the left or right side of the train.

For vibration measurement points used in SKF Rail Track Monitoring, DC-drift during long captures may be significant. Thus, the recommendation is to:

- Enable High Pass filtering with a **Cut-off frequency** set to 0.5 Hz (default).
- Enable custom Full scale, with a range that corresponds to a ± 6 V input change on the channel. For a sensor of sensitivity 10 mV/g, this would be 600 g.

The value 0 would correspond to the full range of channel. Custom full scale can be set from between 0.8% to 94% of the maximum range of the channel.

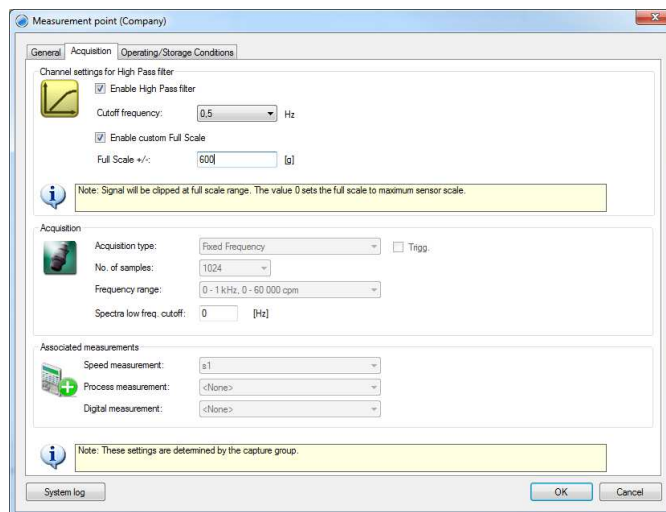

Figure D - 12.
Modifying channel settings for high pass filter

Note that after the IMx has been configured (network/measurement) and the train configuration is done, the IMx/train will start to collect data for storage in the database, just like any other 'machine'.

This process is independent of (does not rely on) the rail track monitoring specific configuration (Lines/Stations/Routes). When this latter configuration has been made, software will attempt to match the measured data (based on an estimated distance travelled) to the relevant track sections. This includes any historic data, collected before the rail track monitoring element of the configuration was in place.

Rail track monitoring configuration

Regions and Lines

The configuration defines the infrastructure being monitored in terms of Regions, Lines, Stations, Features and Routes etc. The configuration of these is achieved by the dedicated RailMo tab, in the tree view window:

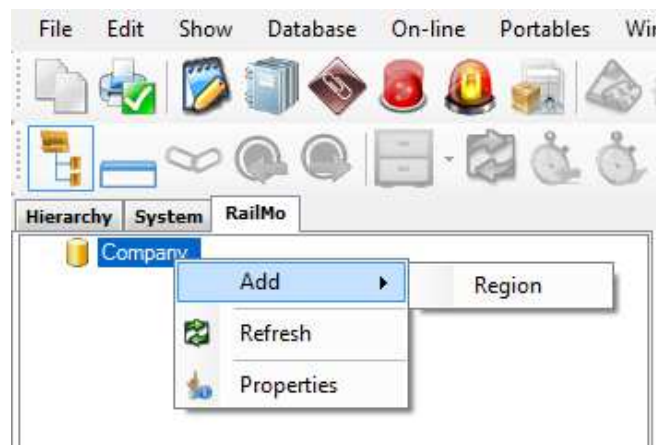

Figure D - 13.
Tree view window, RailMo tab, Add

Starting from the database level, the right click context menu provides the possibility to build up a hierarchical structure using the **Add** function to add Regions and to Add Lines to Regions.

Bounds, Stations and Sections

When a line is created, it automatically includes two bounds (directions of travel) and a first station in each bound. The default naming for these bounds and initial stations can be changed via the context menu and properties:

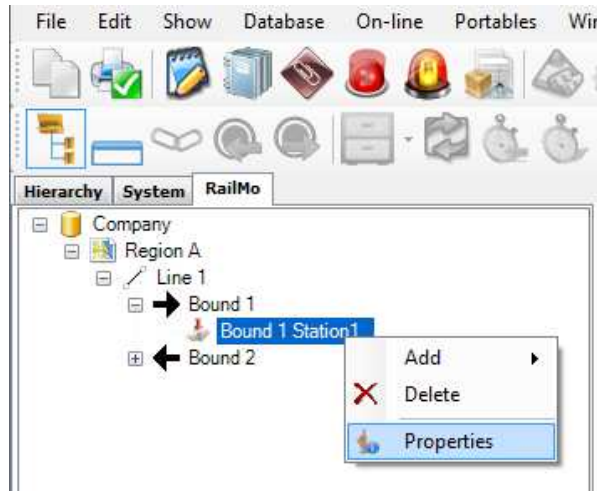

Figure D - 14.
Changing Station properties

In addition to appropriate naming, it is necessary to set in the station properties the **Chainage** and **Position (latitude and longitude)**:

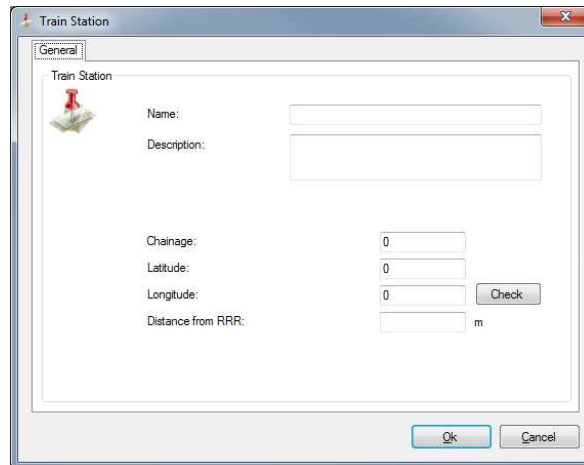

Figure D - 15.
Station properties

Check: helps the user to visually verify the coordinates entered, by opening Google maps at that location.

Note that for the first station created the '**Distance from**' field is not shown (being as this is the origin of the bound). Subsequent stations require this field where the distance in metres from the previous station should be entered. In the figure above the previous station was named 'RRR'.

Continue to add further stations, sequentially, in order of their location along the Line, for each bound (direction of travel):

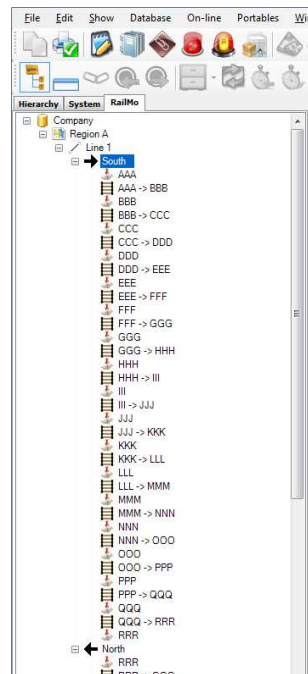

Figure D - 16.
Example of a Line, Bound with Stations and Sections

It can be seen from the above figure, that between each Station, a track section is automatically created. This provides the basic infrastructure data, to which can then be added, Bifurcations (branches), Track section Features and Routes.

A bifurcation can be included by selecting a station and choosing to add either an incoming or outgoing connection:

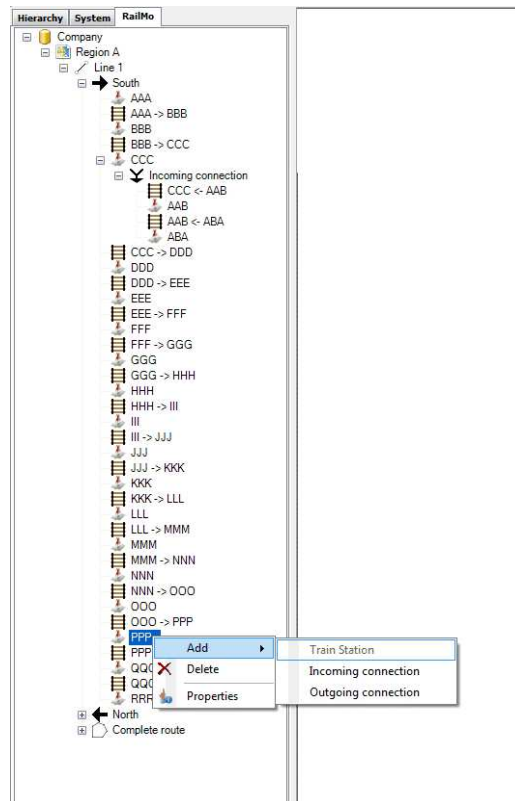

Figure D - 17.
Adding an Incoming or Outgoing connection

This launches the same Station properties dialog, shown in Figure D-15, so as to add the next station on that connection. An incoming connection on this bound means the trains will be travelling into this line from the connecting station, outgoing would be from this line along the added connection.

Note that adding a 'Train Station' is unavailable above because the selected station being added to, is 'mid-line'. It is possible to add connections to any station on the line but a station can only be added to the line, at the end of that line.

Track section features

By right clicking on a Track section, its properties can be accessed:

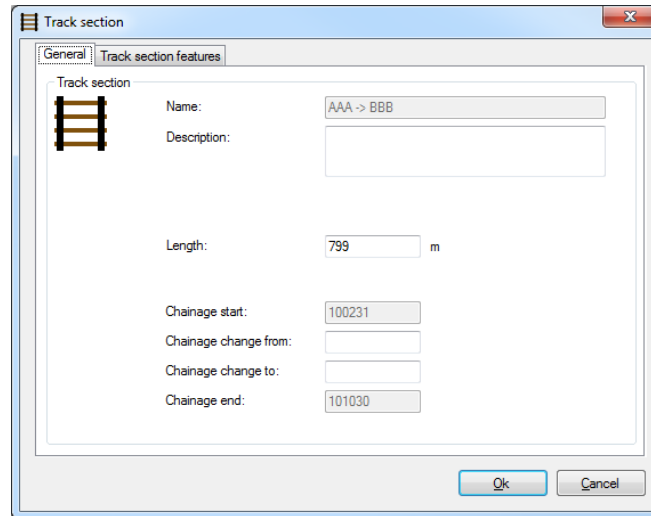

Figure D - 18.
Track section General tab

By switching to the **Track section features** tab, it is possible to view, manage and **Add** features that are encountered within this section. An added Track Section Feature can, for example, be of type: Turnout (points), Bridge, Tunnel, Turn or Another note or Other feature.

When adding a track section feature it is positionally defined by a **Chainage start** and **end** and if required, an **Alert level offset**. Descriptive text can also be included:

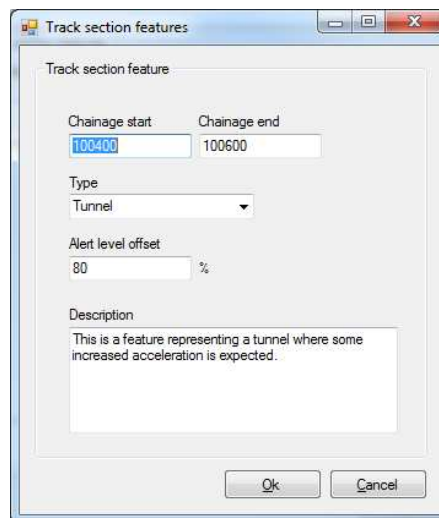

Figure D - 19.
Adding a Track section feature

The Alert level offset is applied to all thresholds whilst within the specified chainage range. For example, enter 0 to leave these thresholds unchanged or 10 to increase them by 10% from their configured values.

Routes

Whilst the Line structure defines how stations are connected, Routes describe how trains are operated on those lines. Routes may therefore encompass the whole or just parts of a Line and one Line may have multiple routes.

The Route data is used by the software to (pattern) match measured data with the correct Track sections. To add a Route, right click on the Line and use the context menu to **Add a Train Route**:

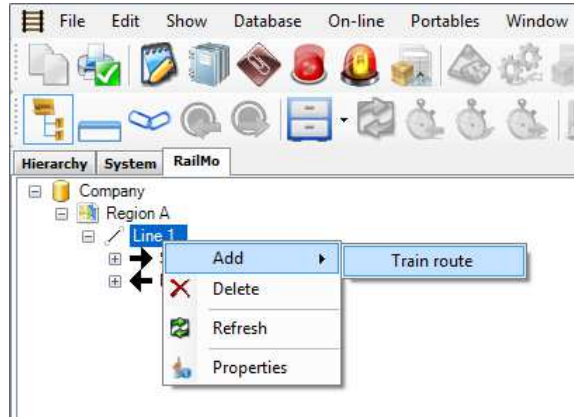

Figure D - 20.
Add Train Route

Now define the Route in terms of the start and stop stations for each Bound:

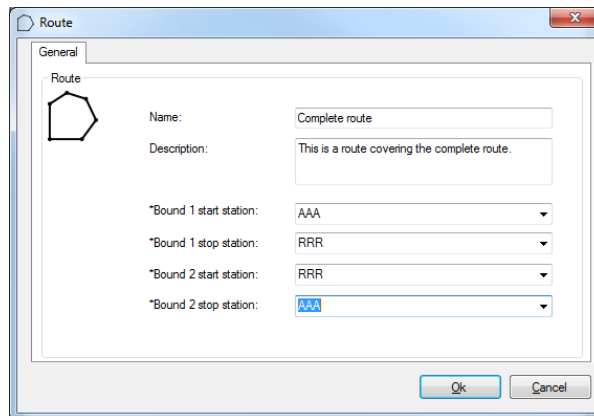

Figure D - 21.
Route properties

Select the appropriate stations from the drop-down list of stations on that line. A name should be given to the route and descriptive text can be added.

The route is now visible in the RailMo view, alongside the two bounds for the line:

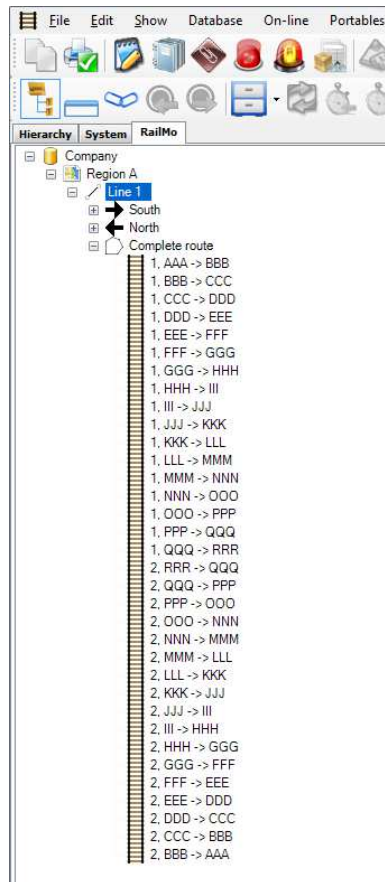

Figure D - 22.
 Rail track monitoring Route

Viewing captures

Rail track monitoring data is a type of IMx capture (Run cycle capture) and as such, in a rail track monitoring system, can be viewed in the [Capture](#) view:

Date/Time	Keep forever	Name	Storage reason	Length [s]	Status	Comment	Track section	Calculated distance
2018-09-05 16:27:10	No		Run Cycle	82,5	Done			
2018-09-05 16:25:25	No		Run Cycle	93,4	Done			
2018-09-05 16:23:21	No		Run Cycle	112,6	Done		EEE -> DDD	862
2018-09-05 16:21:19	No		Run Cycle	110,6	Done		FFF -> EEE	849
N/A	No		Unknown	0,4	Truncated			
2018-09-05 16:19:46	No		Run Cycle	89,6	Done		GGG -> FFF	528
2018-09-05 16:17:14	No		Run Cycle	140,6	Done		HHH -> GGG	1153
2018-09-05 16:15:47	No		Run Cycle	76,6	Done		III -> HHH	497
N/A	No		Unknown	0,4	Truncated			
2018-09-05 16:13:35	No		Run Cycle	119,4	Done		JJJ -> III	933
2018-09-05 16:11:56	No		Run Cycle	88,6	Done		KKK -> JJJ	615
2018-09-05 16:10:04	No		Run Cycle	99,8	Done		LLL -> KKK	738
2018-09-05 16:08:07	No		Run Cycle	104,6	Done		MMM -> LLL	790
2018-09-05 16:06:06	No		Run Cycle	109,8	Done		NNN -> MMM	823
2018-09-05 16:03:48	No		Run Cycle	127,8	Done		OOO -> NNN	1018

Figure D - 23.
 Capture view

For rail track monitoring data captures, the storage reason will be 'Run Cycle' and additional information will be provided here (Track sections and calculated distances) whenever an event capture has been successfully matched.

Matching and pattern recognition

By appropriately configuring the **Wheel diameter**, the system can estimate the distance the train has travelled between stops. Every 10 seconds, the system identifies any uploaded train speed data representing a journey between two stops and calculates an estimated distance travelled.

Once that train has accumulated four such, consecutive 'runs', the total distance travelled is compared with distance data for the configured routes. The **Distance error threshold** is used when deciding if a match has been found. If multiple sections match within that threshold, the one with the lowest error will be used.

Based on this methodology, there are some limitations that can be identified:

- A route is defined by its start and stop (end) stations, all intermediate stations on the line are included.
- It will not match data where the train stops between stations or where it doesn't stop at stations configured for this route.
- The pattern matching can include data from both bounds (example: the journey between the penultimate station and the stop/end station can be considered along with data from the return journey).
- Differences between the inter-station distance and train stop and start positions or variations in where the train stops when calling at a station will introduce errors.
- The matching is not designed to cope with a situation where there are multiple 4-section stretches of track, that have equal length.
- The configuration settings (**Front** and **Rear offset**) are specific to a physical, train configuration. Changing that (adding/removing carriages) whilst retaining incorrect offsets will introduce errors.
- There is currently no functionality to remove incorrectly matched data. If however the data remains unmatched, it can be selected and deleted from the capture view, refer [Figure D - 23](#).

Configuring @ptitude Observer for the Web app

The required configuration parameters are accessed in @ptitude Observer under **Database, Options**.

RailMo tab

Select the RailMo tab:

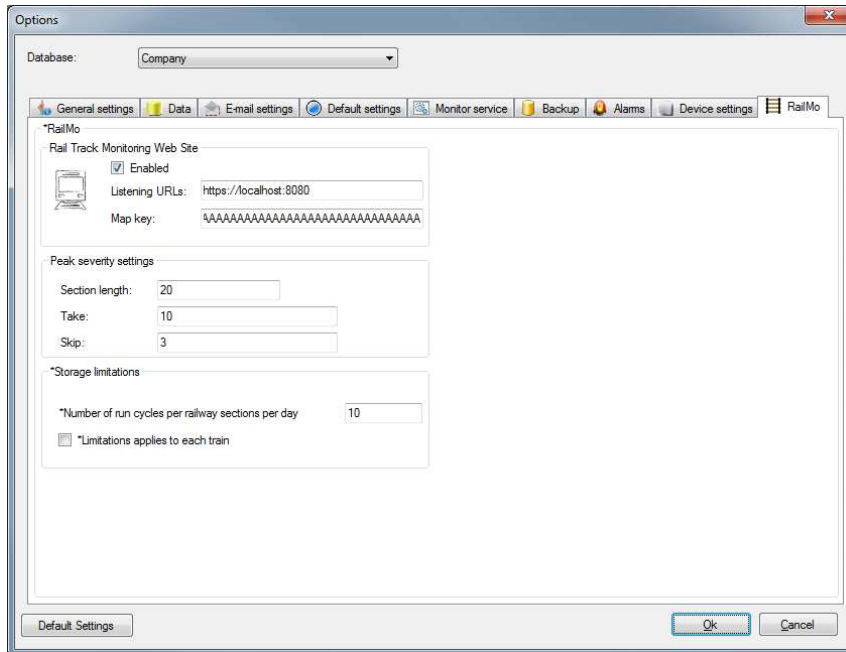

Figure D - 24.
Database Options, RailMo tab

- Check, to enable the web application
- Specify a list of URLs, each URL should be separated by a comma.
 - 'http' and 'https' are supported, 'https' protocol is recommended
- Enter a valid Google map API key

Monitor service tab

Select the Monitor service tab:

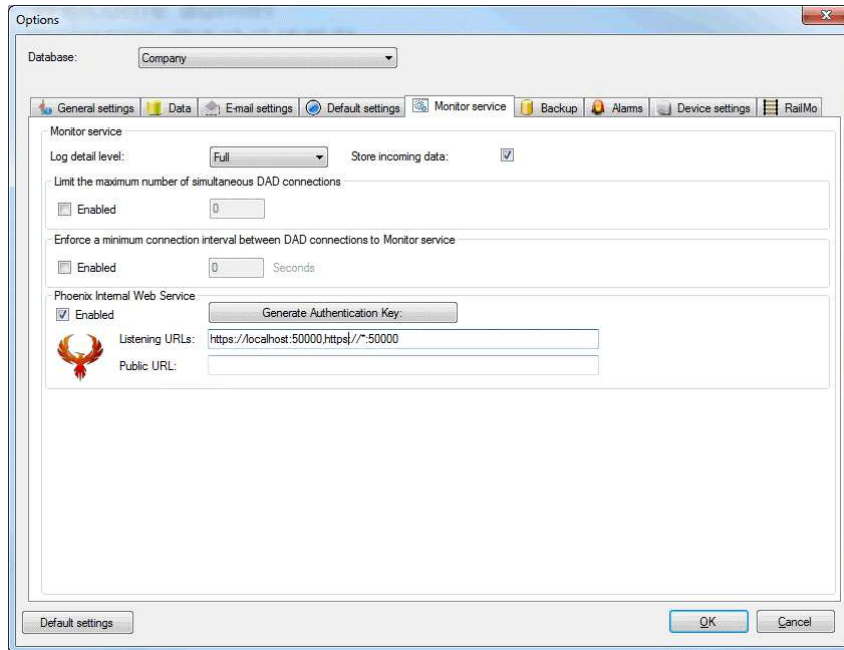

Figure D - 25.
Database Options, Monitor service tab

- Check, to enable the Phoenix internal web service
- Specify appropriate URLs, separate multiple entries by a comma
 - 'http' and 'https' are supported, 'https' protocol is recommended
 - Listening URLs
 - Public URL (if cloud based)

Further information on the Phoenix internal web service is available in [Options](#).

Rail track monitoring security roles

[Security Roles](#) are pre-configured groupings of user rights or privileges. For rail track monitoring two new security roles are available with the following underlying rights:

- Rail Track Monitoring Web View
 - Rail Track Monitoring View
 - Event case View
- Rail Track Monitoring Web Edit
 - Rail Track Monitoring View
 - Event case View
 - Rail Track Monitoring Edit
 - Event case Edit

As the name suggests, the role Rail Track Monitoring Web View will permit users with that role to view maps and exceptions. The role Rail Track Monitoring Web Edit, has the same view rights but adds the further rights needed to make changes.

An administrator should add such users as are required to access and use the web application.

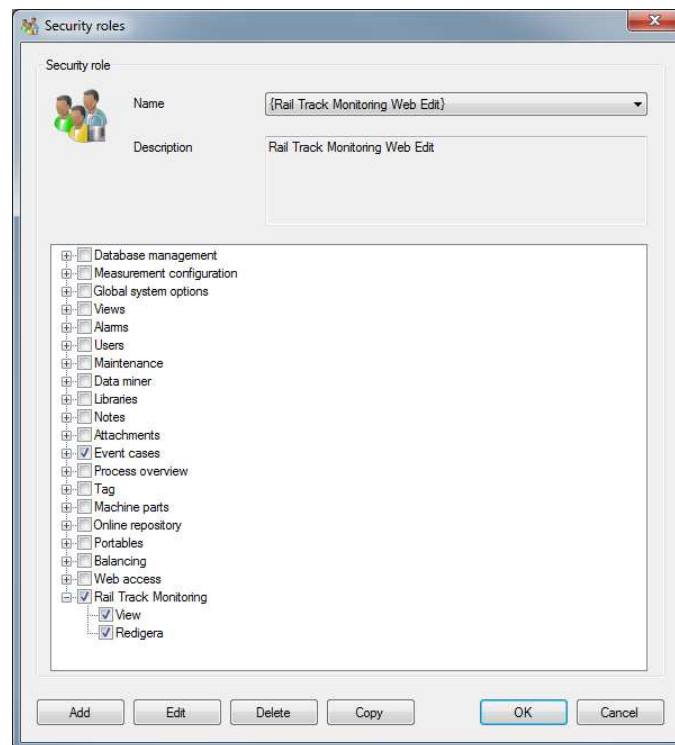

Figure D - 26.
Rail Track Monitoring Web Edit – Security role

An appropriate user login is required before the Web App can be accessed.

@ptitude Observer Analysis Tools

Once data has been gathered and matched, an analyst can review the track condition in @ptitude Observer software using the following tools:

- Summary table – quickly identify track sections with highest severity events
- Scatter plot – section overview showing separate data for left and right rails
- Bubble graph – combining trend and severity information for a length of track
- Time waveform and spectrum – the vibration data collected from a length of track.

Summary table

The summary table provides an overview of a Railway Line, highlighting the severity index and number of exceptions associated with each Track section:

North				South			
Station of departure	Number of exceptions	Vibration amplitude	Station of arrival	Station of departure	Number of exceptions	Vibration amplitude	Station of arrival
PPP	1	Orange	OOO	AAA	0	Green	BBB
RRR	0	Green	QQQ	BBB	0	Green	CCC
GGG	0	Green	PPP	CCC	0	Green	DDD
OOO	0	Green	NNN	DDD	0	Green	EEE
NNN	0	Green	MMM	EEE	0	Green	FFF
MMM	0	Green	LLL	FFF	0	Green	GGG
LLL	0	Green	KKK	GGG	0	Green	HHH
KKK	0	Green	JJJ	HHH	0	Green	III
JJJ	0	Green	III	III	0	Green	JJJ
III	0	Green	HHH	JJJ	0	Green	KKK
HHH	0	Green	GGG	KKK	0	Green	LLL
GGG	0	Green	FFF	LLL	0	Green	MMM
FFF	0	Green	EEE	MMM	0	Green	NNN
EEE	0	Green	DDD	NNN	0	Green	OOO
DDD	0	Green	CCC	OOO	0	Green	PPP
CCC	0	Green	BBB	PPP	0	Green	QQQ
BBB	0	Green	AAA	QQQ	0	Green	RRR

Figure D - 27.
Summary table, example

- Both bounds are shown (in this example named North and South)
- The names of the boundary stations for each track section are shown
- A numeric value for the number of exceptions is displayed
- Track sections are ordered in the table, as follows:
 - First by the number of exceptions
 - Then by the order of the stations along the line

- The severity is colour coded (applies also to Scatter and Bubble plots)
 - Below info level: Green
 - Info: Yellow
 - Warning: Orange
 - Alarm: Red
 - Critical: Dark red

The user may filter the data by pressing enable filter and setting the date range for the data, in this way historical data can be reprocessed. **Take** and **Skip**, is explained in [Peak severity settings](#).

The colour bars for severity are 'clickable' and will open a scatter plot for that section, within that bound.

Scatter plot

A scatter plot provides an overview of data for a section of a bound:

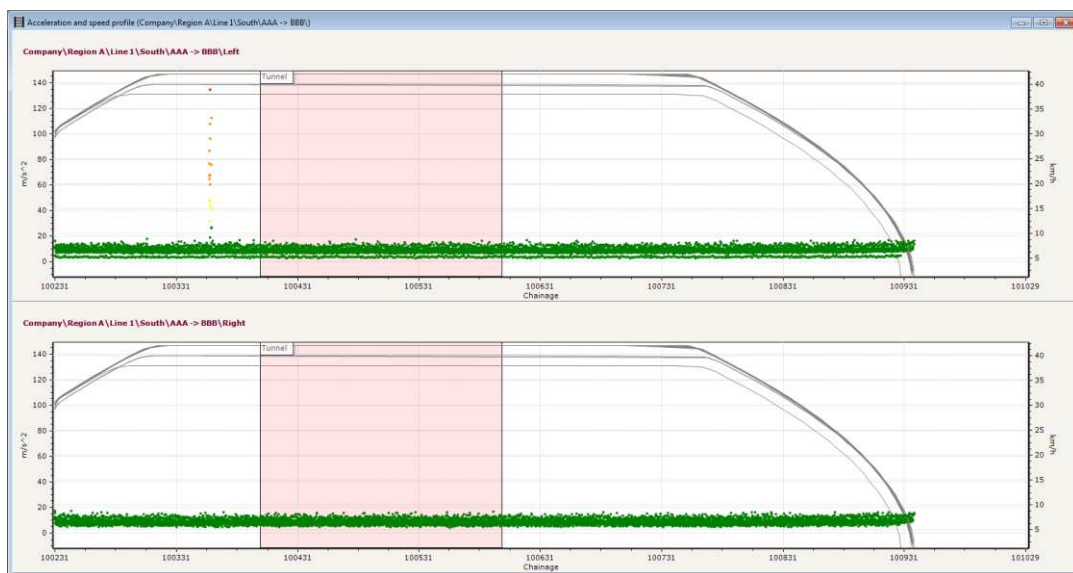

Figure D - 28.
Scatter plot, example

- The left and right rails are presented separately
- Historical data is over plotted, against track position (chainage)
- The location of features is indicated by a coloured overlay or band
 - Example in the figure above: Tunnel
- Vibration severity is plotted as colour coded dots
 - left hand scale applies
- Measured, train speed profiles for the section are graphed
 - right hand scale applies

The plots are auto-scaled and the same scale is applied to both rails. Click on a severity dot in one of the graphs to open a bubble graph.

Bubble graph

A bubble graph is a way of displaying historical severity data for a single rail within a section to highlight trends or changes in the data (worsening damage or damage zone extending).

- Each 'bubble' represents a consolidated (peak acceleration) value for 1 m of rail
- The bubble is sized according to amplitude (and colour coded based on severity)
- The x-axis is location (chainage)
- The y-axis is time (sequential data sets, that have been captured by trains)

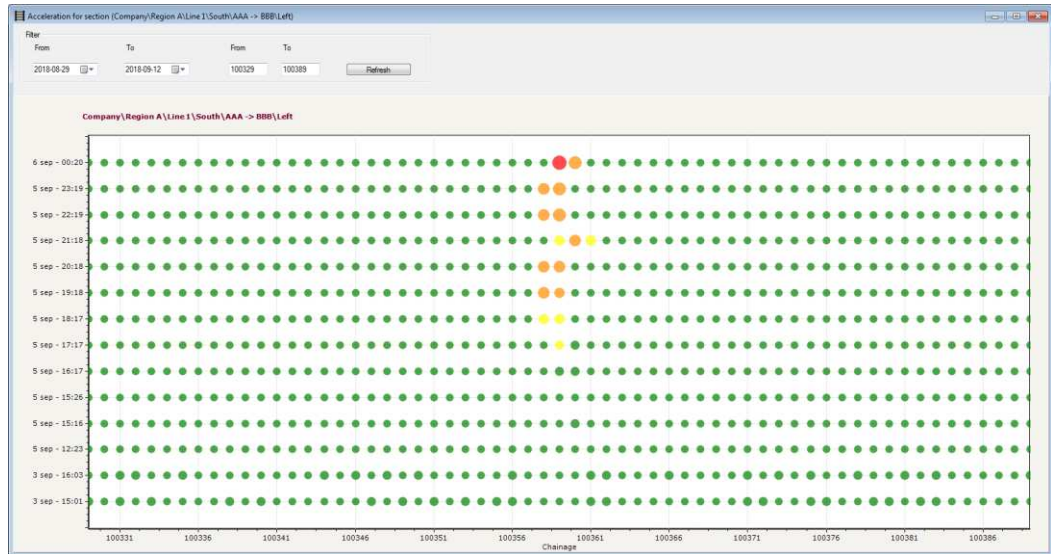

Figure D - 29.
Bubble graph, example

The Filter zone above the plot, shows the current data range (date and chainage) and can be adjusted to move the view along and across the available rail severity data.

Click on a bubble to open a time waveform and spectrum display for that data.

Time waveform and spectrum display

The time waveform and spectrum display accesses the 'raw' data for that rail sub section, within the selected dataset:

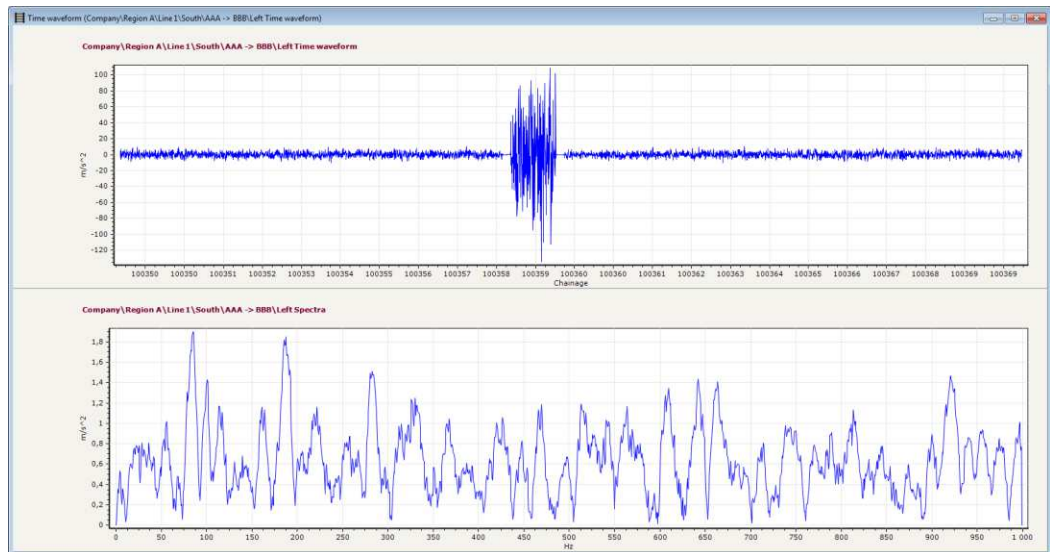

Figure D - 30.
Time waveform and spectrum display, example

'Time waveform', in rail track monitoring, plots the vibration waveform against chainage (rather than time) and the spectrum is a conventional acceleration FFT of that data, plotting acceleration amplitude (peak) against frequency.

Event case and Exception workflows

Creating an Exception

In @ptitude Observer an Exception is based on the following:

- An event case, to which is added:
 - A report
 - An assessment
 - Supporting pictures (charts, graphs etc.)

Further background on event cases, reports and assessments can be found in [Event Cases](#).

To start this process, select the Track section to which the exception will apply and open 'Event cases':

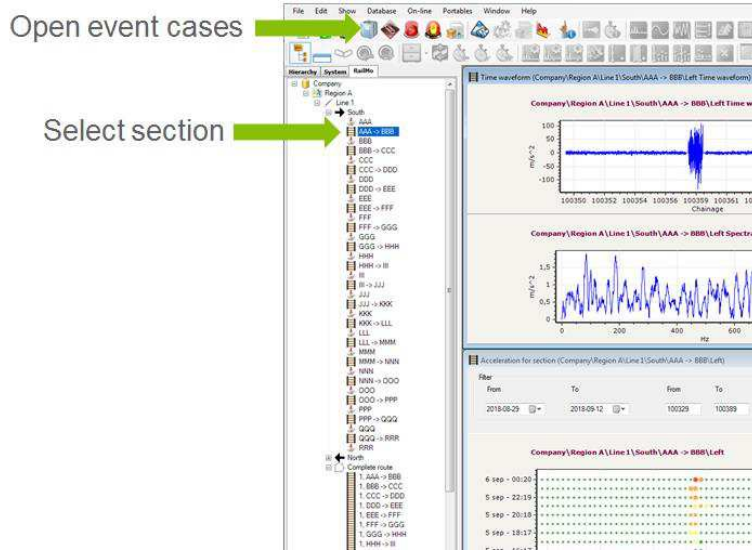

Figure D - 31.
Open an Event case

When the event case dialog opens, a list of existing event cases is displayed and the opportunity to create one is provided by the 'New' button. When the Edit Event case dialog opens, click **Add**, to add a Report*.

*Note that in creating an Event case for rail track monitoring, no user entries are needed in the 'General Settings' fields of the Edit event case, dialog.

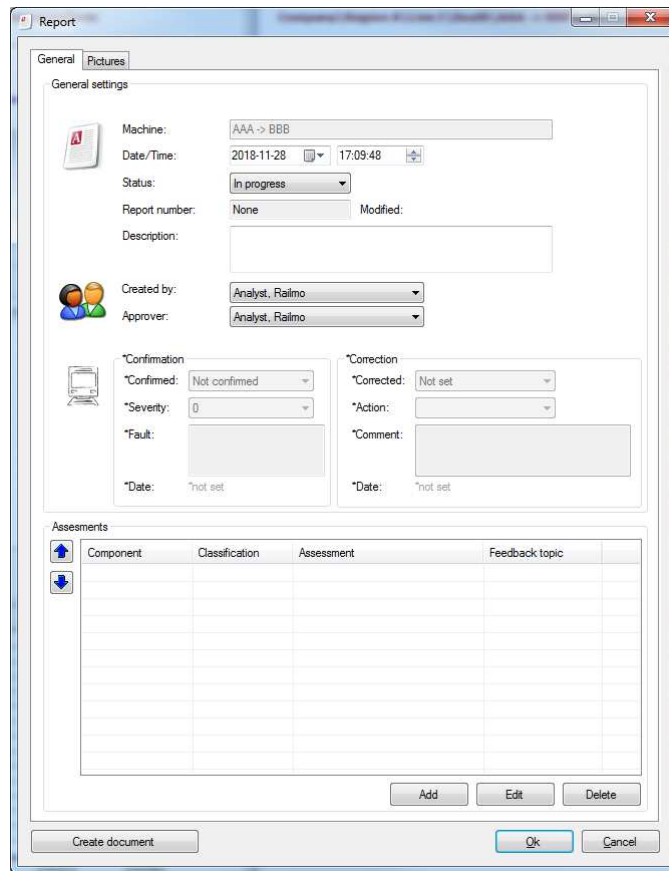

Figure D - 32.
Rail track monitoring Report dialog

In the **Report** dialog, shown above:

- In the **Description** text box, add a meaningful description for the report
 - **Created by** and **Approver** fields: are not used in rail track monitoring
 - **Confirmation/Correction** fields: will feedback information from the customer
- Now click **Add**, to add an Assessment to the report

The screenshot shows a standard Windows-style dialog box titled "Assessment". It features a title bar with a close button. The main area is divided into several sections: "Classification" with a dropdown menu showing "4"; "Machine part" with a dropdown menu showing "<Not selected>"; "*Chainage Range" with a text box containing "100355" and a range indicator "- 100362"; "*Rail" with a text box containing "Left"; "Assessment" with a large text area containing "Some assesment from the analyst."; "Recommendation" with a large text area containing "Possibility to recommend any action."; "Feedback topic" with a dropdown menu showing "[None]"; and "Feedback" with a text area. At the bottom right, there are "Ok" and "Cancel" buttons.

Figure D - 33.
Rail track monitoring Assessment dialog

In completing the assessment, the analyst should:

- Enter a **Classification** (range 1 to 10, where 10 is worst/highest priority)
- Fill-in the **Chainage Range** and the **Rail ID** to which the assessment applies
 - In this case the ID could for example be: Left, Right or Left+Right
- Optionally:
 - Enter free text to describe the **Assessment** and any **Recommendation**
 - Note these optional elements are not included in the web display

Having created the assessment, the **Pictures** tab of the **Report** dialog can be used to add supporting images to exceptions (graphs, tables etc.). Images can be added from either the clipboard or the active window in @ptitude Observer:

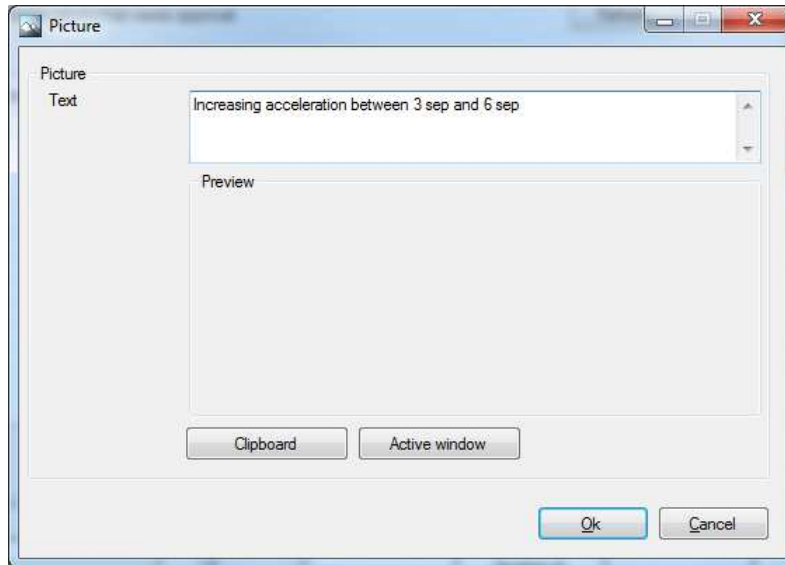

Figure D - 34.
Report, Pictures tab, Add Picture

Select the desired image and add a meaningful description in the **Text** box:

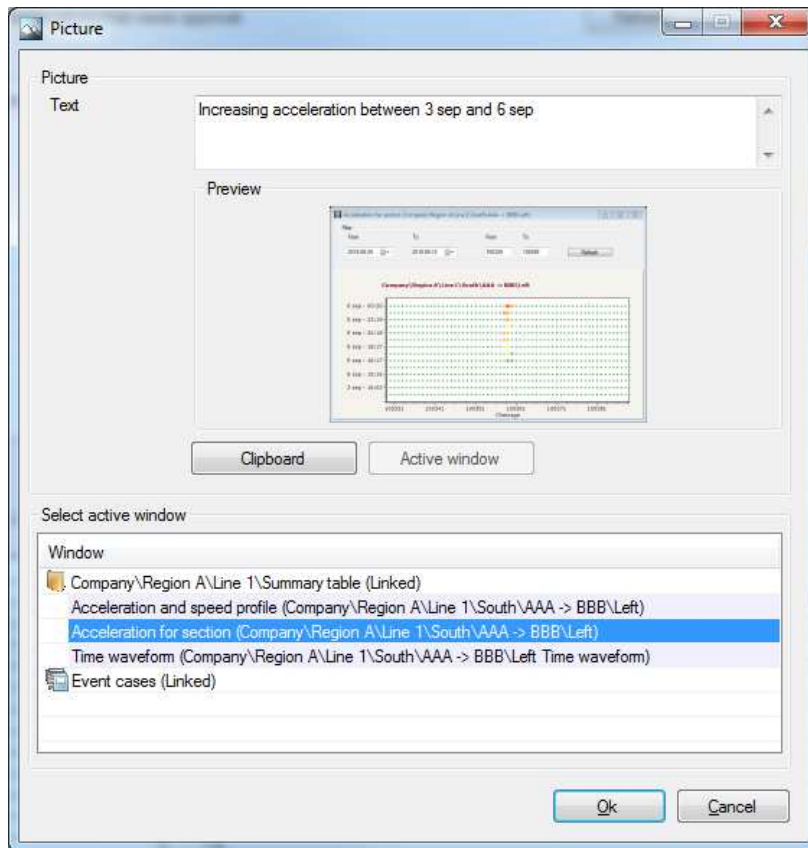

Figure D - 35.
Add from active window, example

Exception feedback

When an Exception has been processed by the customer, the report is automatically updated with the **Confirmation** (results of visual inspection) and where appropriate, the **Correction** (corrective actions) applied, refer also [Processing and closing exceptions.](#)

Report

General Pictures

General settings

This report has been released and can't be modified.

Machine: AAA -> BBB

Date/Time: 2018-11-28 17:09:48

Status: Released

Report number: 1 Modified: 2018-11-28 17:14:18

Description:

Created by: Analyst, Railmo

Approver: Analyst, Railmo

*Confirmation

*Confirmed: Confirmed exception

*Severity: 1

*Fault: 301 - Defects caused by damage to the rail - Full section - Bruising

*Date: 2018-11-28 17:21:53

*Correction

*Corrected: Fixed

*Action: Other - See comment...

*Comment: Changed parts

*Date: 2018-11-28 17:22:09

Assesments

Component	Classification	Assessment	Feedback topic
<Not selected>	4	Some assesment from the analyst.	[None]

Create document Add View Delete Ok Cancel

Figure D - 36.
Report updated with Exception, feedback

This closes the loop and the Event case status will also be similarly updated (open Event Cases, to view).

Using the Web App

Introduction to the Web application

This web app can be hosted on a local network or can be cloud based and provides easily viewed status information for the rail infrastructure. To access the web app, navigate to the configured URL where the login page will be displayed.

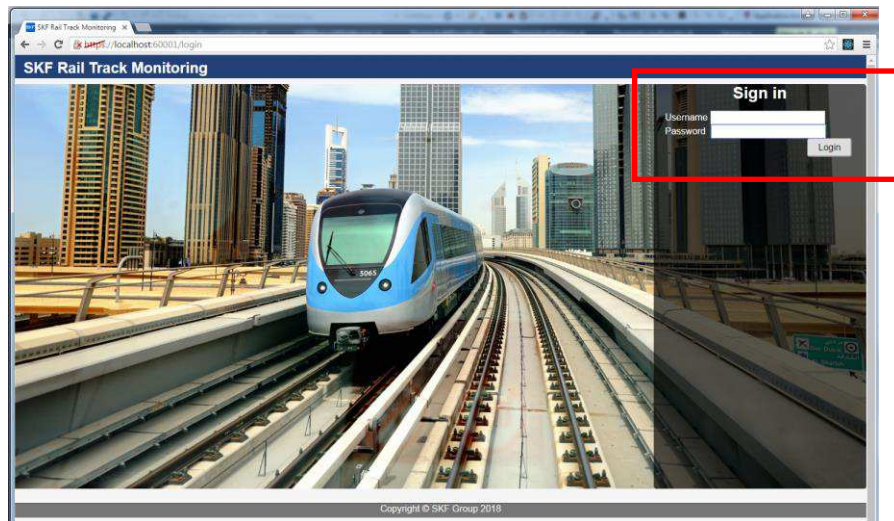

Figure D - 37.
Login screen

Only users with the appropriate rights and [Rail track monitoring security roles](#) can access the system. At first login, it is mandatory to **Accept** the EULA:

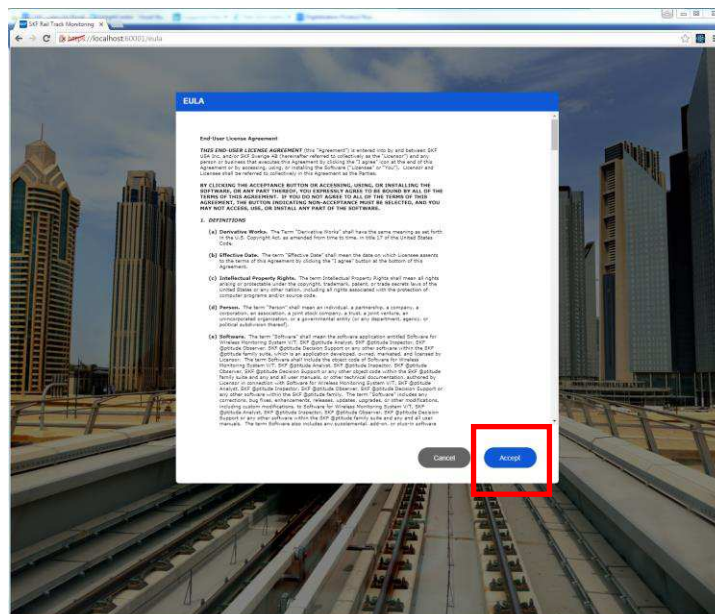

Figure D - 38.
EULA

The app displays as a main panel, with a blue navigation bar on the left side:

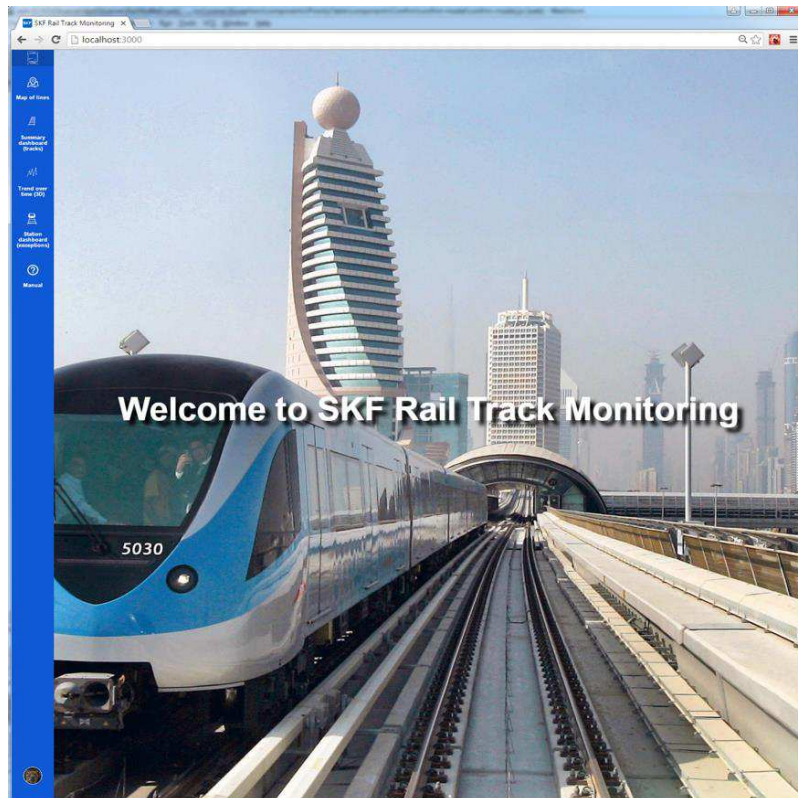

Figure D - 39.
Welcome screen

In that navigation bar there are options for:

- Map of lines – to open a map displaying the lines/line information
- Station dashboard (exceptions) – to list recorded exceptions

Map of lines

On selecting the Map of Lines option, the main panel now displays a Google map on which the lines are displayed, each line is coloured by the severity. The lines are drawn based on station locations (not a representation of the actual routing) and is initially zoomed and panned to fit the lines, although it can be further zoomed and/or panned as needed.

Clicking on a line will show additional information:

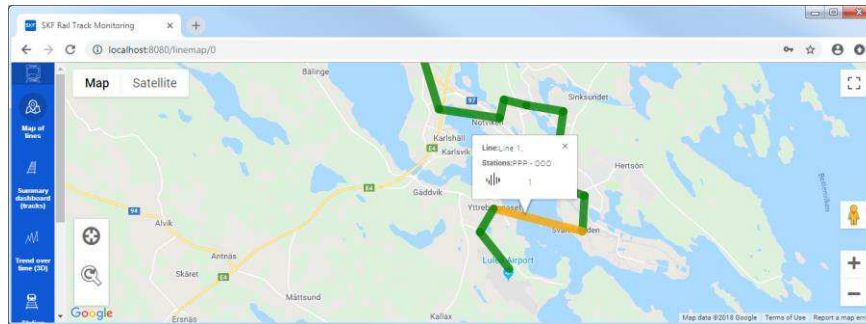



Figure D - 40.

Clicking on a line section for further information (zoom 1 example)

In the lower left corner of the map display are two controls to 'recover' the map pan and zoom settings and bring the lines in view:

-  Pan to railway bounds button, pans the map so that the railway is visible in the map.
-  Zoom to railway bounds button, resets to the default zoom and pan, to fit and centre the map for the lines.

At three zoom levels the level of detail, routinely shown, changes:



Figure D - 41.
Line map, zoom

Zoom1

- The Railway Line is drawn as a single line
- Stations are shown as dots

Zoom 2

- As zoom 1 but with:
- The Railway Line drawn as two lines (representing each bound)
- Stations shown by their names (and a location 'pin', coloured red)

Zoom 3

- As zoom 2 but with:
- A 'call-out' on each section and bound, containing the Exception count

Station dashboard

The Station dashboard groups open exceptions by Line, Track section (from station to station) and bound:

Line	From	To	Bound				
Line 1	AAA	BBB	South				
ID	Date	Chainage	Rail	Analyst Severity	Confirmed	Action	Charts
36	2018, Nov, 29, 09:18	100360-100370	Left+Right	7	<input type="checkbox"/>	Confirm	Not set, please confirm
Line	From	To	Bound				
Line 1	PPP	OOO	North				
ID	Date	Chainage	Rail	Analyst Severity	Confirmed	Action	Charts
34	2018, Oct, 31, 02:06	10-20		8	<input checked="" type="checkbox"/>	Record action	Select chart...

Figure D - 42.
Station dashboard, example

Within such a group, all open exceptions are listed together with the following supporting information:

- **ID**
- **Date** of creation
- **Chainage** – identifying the specific length of rail, concerned
- **Rail** – Left, Right or Left+Right
- **Analyst Severity** - as set by the analyst
- **Confirmed** - Confirmation information, if any

- **Action** information, if any
- **Charts** – provides access to any images the analyst has attached

Confirmed and **Action** information are a part of the Exception workflow and record the customers actions and feedback while closing out the exception. Once an exception is closed, it will no longer be visible in the web app.

Processing and closing exceptions

The first stage is normally to visually inspect the region of track against which the exception has been raised. The results of that inspection can be recorded against the exception by pressing the associated **Confirm** button, for that exception. This launches a new dialog:

The dialog box is titled "Confirm exception by visual inspection" and features a close button (X) in the top right corner. It contains the following elements:

- Two radio buttons:
• *Exception can not be found by visual inspection (unselected)
• *Exception exists (selected)
- *Date of confirmation: A text input field containing "2018-10-09" and a calendar icon on the right.
- *Severity of exception during visual inspection: A dropdown menu with "1" selected.
- *Type of problem (digit 1): A dropdown menu with "Defects in rail ends" selected.
- *Type of problem (digit 2): A dropdown menu with "Web" selected.
- *Type of problem (digit 3): A dropdown menu with "Horizontal cracking" selected.
- *Type of problem (digit 4): A dropdown menu with "at the web-head fillet radius" selected.
- Two buttons at the bottom: "Cancel" (white with blue border) and "OK" (solid blue).

Figure D - 43.
Confirm exception dialog

If the exception is confirmed (a defect exists), after entering the date the inspection was performed, the dialog uses a series of drop-downs to classify the findings in

terms of the type and severity of the defect seen. Using drop-downs rather than free-text to describe the defect, allows it to be objectively classified.

The numeric coding used to classify defect type is based on the International Railway Solution (IRS) 70712, Rail Defects.

Second stage is to record the corrective action taken (if any). This is achieved by pressing the associated **Record action** button, for that exception. The dialog opens:

The dialog box is titled "Record corrective action" and contains the following elements:

- Two radio buttons: *Defect NOT fixed. and *Defect fixed.
- A text input field for *Date of correction with the value "2018-10-09" and a calendar icon.
- A dropdown menu for *Type of action with the selected option "No specific. See comment".
- A text area for Comment.
- Two buttons at the bottom: "Cancel" and "OK".

Figure D - 44.
Record corrective action, dialog

In this instance a drop-down for the type of action taken (if any) plus a free-text area for further comment, are provided.

When a defect found (or not found) and a fix (or no fix) have been registered, the exception is closed.

Appendix E

End User License Agreement

THIS END-USER LICENSE AGREEMENT

(this "Agreement") is entered into by and between SKF USA Inc. and/or SKF Condition Monitoring Center AB (hereinafter referred to collectively as the "Licensor") and any person or business that executes this Agreement by clicking the "I agree" icon at the end of this Agreement or by accessing, using, or installing the Software ("Licensee" or "You"). Licensor and Licensee shall be referred to collectively in this Agreement as the Parties.

BY CLICKING THE ACCEPTANCE BUTTON OR ACCESSING, USING, OR INSTALLING THE SOFTWARE, OR ANY PART THEREOF, YOU EXPRESSLY AGREE TO BE BOUND BY ALL OF THE TERMS OF THIS AGREEMENT. IF YOU DO NOT AGREE TO ALL OF THE TERMS OF THIS AGREEMENT, THE BUTTON INDICATING NON-ACCEPTANCE MUST BE SELECTED, AND YOU MAY NOT ACCESS, USE, OR INSTALL ANY PART OF THE SOFTWARE.

1. DEFINITIONS

- (a) **Derivative Works.** The Term "Derivative Works" shall have the same meaning as set forth in the U.S. Copyright Act, as amended from time to time, in title 17 of the United States Code.
- (b) **Effective Date.** The term "Effective Date" shall mean the date on which Licensee assents to the terms of this Agreement by clicking the "I agree" button at the bottom of this Agreement.
- (c) **Intellectual Property Rights.** The term Intellectual Property Rights shall mean all rights arising or protectable under the copyright, trademark, patent, or trade secrets laws of the United States or any other nation, including all rights associated with the protection of computer programs

and/or source code.

- (d) **Person.** The term "Person" shall mean an individual, a partnership, a company, a corporation, an association, a joint stock company, a trust, a joint venture, an unincorporated organization, or a governmental entity (or any department, agency, or political subdivision thereof).
- (e) **Software.** The term "Software" shall mean the software application entitled Software for Wireless Monitoring System V/T, SKF @ptitude Analyst, SKF @ptitude Inspector, SKF @ptitude Observer, SKF @ptitude Decision Support or any other software within the SKF @ptitude family suite, which is an application developed, owned, marketed, and licensed by Licensor. The term Software shall include the object code of Software for Wireless Monitoring System V/T, SKF @ptitude Analyst, SKF @ptitude Inspector, SKF @ptitude Observer, SKF @ptitude Decision Support or any other object code within the SKF @ptitude family suite and any and all user manuals, or other technical documentation, authored by Licensor in connection with Software for Wireless Monitoring System V/T, SKF @ptitude Analyst, SKF @ptitude Inspector, SKF @ptitude Observer, SKF @ptitude Decision Support or any other software within the SKF @ptitude family. The term "Software" includes any corrections, bug fixes, enhancements, releases, updates, upgrades, or other modifications, including custom modifications, to Software for Wireless Monitoring System V/T, SKF @ptitude Analyst, SKF @ptitude Inspector, SKF @ptitude Observer, SKF @ptitude Decision Support or any other software within the SKF @ptitude family suite and any and all user manuals. The term Software also includes any supplemental, add-on, or plug-in software code provided to Licensee in the course of receiving Product Support Plan services from

Licensor. The term Software shall not be construed to include the source code for Software for Wireless Monitoring System V/T, SKF @ptitude Analyst, SKF @ptitude Inspector, SKF @ptitude Observer, SKF @ptitude Decision Support or any other software within the SKF @ptitude family suite.

2. LICENSE

(a) Grant of License. Licensor grants Licensee, pursuant to the terms and conditions of this Agreement, a non-exclusive, non-transferable, and revocable license to use the Software in strict accordance with the terms and conditions of this Agreement, including any concurrent use, network or other limitations set forth in subsection (b) below. All rights not specifically granted by Licensor under this Agreement are retained by Licensor and withheld from Licensee.

(b) Installation and Use Rights. Licensee shall use the Software only on its internal computer equipment, whether such equipment is owned, leased, or rented, at the Licensee's principal business office. The following paragraphs govern your installation and use rights with regard to the Software, depending on the type of license you have obtained from Licensor.

(i) If you obtained a stand-alone license of the Software, you may install one (1) copy of the Software on one (1) computer residing in your principal business office.

(ii) If you obtained a network license of the Software, you may install one (1) copy of the Software on as many networked clients (workstations) as authorized by your network license, as set forth more particularly in the applicable purchase order or other ordering documents memorializing your license

acquisition; provided, however, that all network clients (workstations) are connected to a single licensed database residing in your principal business office.

(iii) If you obtained a network license of the Software, you may connect to multiple licensed databases, you may install the database-dedicated clients up to the total number of networked clients acquired by you under the applicable purchase order or other ordering documents memorializing your license acquisition.

(c) Other Conditions of Use. Licensor understands and agrees that the Software works in conjunction and is compatible with database software licensed to you by Microsoft or Oracle. Upon installation of the Software, the Software may detect an installed database software application from Oracle or Microsoft, and if so, the Software will be fully installed. If no installed database software application from Oracle or Microsoft is detected, the Software will not install until such time as Licensee installs a valid and Software compatible copy of an Oracle database or a Microsoft SQL Server database and consents to the license terms of such database software application. If Licensee does not agree to the terms of the Oracle database license or the Microsoft SQL Server license, or if the Licensee fails to install such database software, the Software will not work. Licensee is responsible for maintaining a valid database license in accordance with the Oracle or Microsoft license agreement (which ever is applicable) at all times.

(d) Restrictions on Use. Licensee may use the Software only for its internal business purposes and on

the identified equipment on which the Software was first installed or for which it is otherwise licensed; provided, however, that Licensee may temporarily use the Software on a back-up system in the event that the primary licensed system is inoperative or test system not used for production but solely for the purposes of testing the Software. Licensee may not use the Software for any other purpose. Licensee shall not:

- (i) permit any parent, subsidiaries, affiliated entities or third parties to use the Software;
- (ii) use the Software in the operation of a service bureau;
- (iii) allow access to the Software through any workstations located outside of Licensee's principal business offices;
- (iv) rent, resell, lease, timeshare or lend the Software to any Person;
- (v) sublicense, assign, or transfer the Software or this license for the Software to any Person;
- (vi) reproduce, distribute, or publicly display the Software;
- (vii) make the Software accessible to any Person by any means, including posting on a web site or through other distribution mechanisms over the Internet;
- (viii) reverse assemble, disassemble, reverse engineer, reverse compile, decompile, or otherwise translate the Software or prepare Derivative Works based on the Software;
- (ix) place, reproduce, or make available the Software on Licensee's computer network

if Licensee is only authorized by this Agreement to operate the Software on a single workstation;

- (x) exceed at any given point in time the total number of network clients authorized by the applicable purchase order or ordering document to use or access the Software;
 - (xi) edit or modify the Software except as expressly authorized by Licensor, including altering, deleting, or obscuring any proprietary rights notices embedded in or affixed to the Software;
 - (xii) use the Software in any manner that disparages Licensor, Microsoft, or Oracle, or use the Software in a way that infringes the Intellectual Property Rights of the foregoing parties; or
 - (xiii) use the Software in a manner that violates any federal, state, or local law, rule or regulation, or use the Software to violate the rights of any third party, or use the Software to promote pornography, hatred, or racism.
- (e) **Copies.** Licensee, solely to enable it to use the Software, may make one archival copy of the Software's computer program, provided that the copy shall include Licensor's copyright and any other proprietary notices. The Software delivered by Licensor to Licensee and the archival copy shall be stored at Licensee's principal business office. If you purchased a network license of the Software, you may install one additional copy of the Software on your network for the limited purpose of testing the Software's operation. Except for the limited reproduction rights set forth in this paragraph, Licensee shall have no other right to copy, in whole or in part, the

Software. Any copy of the Software made by Licensee is the exclusive property of Licensor.

(f) **Modifications.** Licensee agrees that only Licensor shall have the right to alter, maintain, enhance or otherwise modify the Software.

(g) **Protection of Software.** Licensee agrees that it will take action by instruction, written agreement, or otherwise as appropriate with any person permitted access to the Software to enable Licensee to comply with its obligations hereunder. Licensee shall maintain records of the number and location of all copies of Software. Licensee shall not provide, permit access to or use of, or otherwise make available any Software in any form without Licensor's prior written agreement, except to Licensee's employees for purposes specifically authorized by this Agreement. Licensee understands and agrees that the source code for the Software is a valuable copyright and contains valuable trade secrets of Licensor. Licensee agrees not to discover or attempt to discover, or assist or permit any Person to discover or attempt to discover, by any means whatsoever the source code of the Software.

(h) **Licensor's Audit Rights.** Licensor shall possess the right to audit Licensee's use of the Software to determine compliance with this Agreement (hereinafter referred to as "Licensor's Audit Rights"). Licensor's Audit Rights shall be exercised in accordance with the following paragraphs:

(i) **Notice of Audit.** Licensor shall provide Licensee with at least five (5) calendar days advance written notice of its intent to exercise the Licensor's Audit Rights.

(ii) **Conduct of Audit.** The audit conducted by Licensor shall

consist of a physical review of the computer hardware, software, and middleware operated by Licensee at its principal business office and any other office for which Licensor, in its sole and arbitrary discretion, deems an audit appropriate. Licensee shall provide Licensor with unrestricted access to its computer hardware, software, and middleware in connection with any audit conducted by Licensor.

(iii) **Costs of Audit.** If Licensor's audit uncovers a violation of this Agreement by Licensee, Licensee shall pay all costs and expenses incurred by Licensor in exercising the Licensor Audit Rights, including, without limitation, all attorneys' fees and agent fees incurred by Licensor. If Licensor concludes that no violation of this License Agreement has occurred, Licensor shall bear all costs and expenses incurred in exercising the Licensor Audit Rights. If Licensee obstructs, restricts, or otherwise prevents Licensor from conducting a full and unrestricted audit, Licensee shall bear all costs and expenses, including attorneys' fees, incurred by Licensor in enforcing this Section 2(h) before any court or judicial tribunal.

(iv) **Frequency of Audits.** Licensor's Audit Rights shall be exercised no more than two (2) times in any one calendar year.

(i) **Validity of Intellectual Property Rights.** In any action, dispute, controversy, or lawsuit arising out of or related to this Agreement, Licensee shall not contest the validity of Licensor's Intellectual Property

Rights related to the Software. Licensee hereby agrees that it has had an opportunity to investigate the validity of Licensor's Intellectual Property Rights, and acknowledges that Licensor's Intellectual Property Rights related to the Software are valid and enforceable.

- (j) **Material Terms and Conditions.** Licensee specifically agrees that each of the terms and conditions of this Section 2 are material and that failure of Licensee to comply with these terms and conditions shall constitute sufficient cause for Licensor to terminate this Agreement and the license granted hereunder immediately and without an opportunity to cure. This subsection 2(j) shall not be construed to preclude, or in any way effect, a finding of materiality with respect to any other provision of this Agreement.

3. LICENSE FEE

The applicable licensee fees will be set forth in the quote issued to Licensee by Licensor or otherwise established in the applicable purchase order or other ordering documents memorializing your license acquisition.

4. OWNERSHIP

- (a) **Title.** Licensee understands and agrees that Licensor owns all Intellectual Property Rights related to the Software, including custom modifications to the Software, whether made by Licensor or any third party. Licensee agrees that this Agreement effects a license, not a sale, of the Software and that the first sale doctrine, as codified in 17 U.S.C. § 109, does not apply to the transaction effected by this Agreement.
- (b) **Transfers.** Under no circumstances shall Licensee sell, license, sublicense, publish, display, distribute, assign, or otherwise transfer (hereinafter referred to collectively as a "Transfer") to a third party the Software or any copy thereof, in whole or in part, without Licensor's prior written consent. Any Transfer effected in violation of this Section 4(b) shall be void ab initio and of no force or effect.

5. MAINTENANCE AND SUPPORT

Licensor may provide you with support services related to the Software called Product Support Plan ("PSP") services. Use of PSP is governed by the policies and programs described in the PSP literature or other material from Licensor's Product Support Department (hereinafter referred to as the "PSP Policies") that may be updated by Licensor from time to time. If you select and pay for PSP, the PSP Policies shall be specifically incorporated into this Agreement by this reference. Licensee acknowledges that Licensor may use any technical information provided by Licensee in the course of receiving PSP services for Licensor's business purposes, including for product support and development. Licensor will not utilize such technical information in a manner that identifies Licensee.

6. CONFIDENTIAL INFORMATION

Licensee agrees that the Software contains proprietary information, including trade secrets, know-how and confidential information (hereinafter referred to

collectively as the “Confidential Information”), that is the exclusive property of Licensor. During the period this Agreement is in effect and at all times after its termination, Licensee and its employees and agents shall maintain the confidentiality of the Confidential Information and shall not sell, license, publish, display, distribute, disclose or otherwise make available the Confidential Information to any Person nor use the Confidential Information except as authorized by this Agreement. Licensee shall not disclose the Confidential Information concerning the Software, including any flow charts, logic diagrams, user manuals and screens, to persons not an employee of Licensee without the prior written consent of Licensor.

7. LIMITED WARRANTIES

(a) Licensor warrants that the Software will perform substantially in accordance with its documentation for a period of 180 days from the date of shipment of the Software; provided, however, that the foregoing warranty only applies if: (i) Licensee makes Licensor aware of any defect with the Software within seven (7) days after the occurrence of the defect; (ii) Licensee has paid all amounts due under this Agreement; and (iii) Licensee has not breached any provision of this Agreement. The foregoing warranty does not apply in the event that: (i) the Software and documentation have been subject to misuse, neglect, alteration, modification, customization, improper installation, and/or unauthorized repair; (ii) the Software or any associated software or equipment have not been properly maintained in accordance with applicable specifications and industry standards or have been maintained in unsuitable environmental conditions; or (iii) Licensee has used the Software in conjunction with other equipment, hardware, software, or other technology that created an adverse impact on the operation, functioning, or performance of the Software.

(b) EXCEPT AS SET FORTH IN THIS SECTION 7 AND TO THE EXTENT PERMITTED BY APPLICABLE LAW, ALL EXPRESS AND/OR IMPLIED WARRANTIES OR CONDITIONS, INCLUDING BUT NOT LIMITED TO IMPLIED WARRANTIES OR CONDITIONS OF MERCHANTABILITY, MERCHANTABILITY OF A COMPUTER PROGRAM, INFORMATIONAL CONTENT, SYSTEM INTEGRATION, FITNESS FOR A PARTICULAR PURPOSE, AND NON-INFRINGEMENT, ARE HEREBY DISCLAIMED AND EXCLUDED BY LICENSOR.

(c) The remedies set forth in this Section 7 are the exclusive remedies available to Licensee for any problem in the performance of the Software.

8. LIMITATIONS ON LIABILITY

(a) **Limitations and Exclusions.** IN NO EVENT WILL LICENSOR BE LIABLE TO LICENSEE FOR ANY DIRECT, INDIRECT, INCIDENTAL, CONSEQUENTIAL, PUNITIVE OR OTHER SPECIAL DAMAGES, LOST PROFITS, OR LOSS OF INFORMATION SUFFERED BY LICENSEE ARISING OUT OF OR RELATED TO THIS AGREEMENT OR THE USE OF THE SOFTWARE, FOR ALL CAUSES OF ACTION OF ANY KIND (INCLUDING TORT, CONTRACT, NEGLIGENCE, STRICT LIABILITY, BREACH OF WARRANTY OR CONDITION, AND STATUTORY) EVEN IF LICENSOR HAS BEEN ADVISED OF THE POSSIBILITY OF SUCH DAMAGES. THE PRECEDING EXCLUSION AND DISCLAIMER OF DAMAGES SHALL APPLY TO ALL CLAIMS MADE BY LICENSEE RELATED TO OR ARISING OUT OF LICENSEE’S USE OF THE SOFTWARE, INCLUDING, BUT NOT LIMITED TO, CLAIMS ALLEGING THAT THE SOFTWARE, OR ANY COMPONENT THEREOF, FAILED OF ITS ESSENTIAL

PURPOSE OR FAILED IN SOME OTHER RESPECT.

- (b) **Acknowledgment.** Licensee agrees that the limitations of liability and disclaimers of warranty set forth in this Agreement will apply regardless of whether Licensor has tendered delivery of the Software or Licensee has accepted the Software. Licensee acknowledges that Licensor has set its prices and entered into this Agreement in reliance on the disclaimers of warranty and the limitations and exclusions of liability set forth in this Agreement and that the same form an essential basis of the bargain between the Parties.

9. TERM AND TERMINATION

- (a) **Term.** This Agreement shall commence on the Effective Date and shall continue in existence until it is terminated in accordance with Section 9(b) below.
- (b) **Termination.** Licensor may terminate this Agreement and the license conveyed hereunder in the event that Licensee breaches any provision, term, condition, or limitation set forth in this Agreement, including but not limited to the license restrictions set forth in Section 2(d) of this Agreement.
- (c) **Effect of Termination.** Within ten (10) days after termination of this Agreement and the license granted hereunder, Licensee shall return to Licensor, at Licensee's expense, the Software and all copies thereof, and deliver to Licensor a certification, in writing signed by an officer of Licensee, that all copies of the Software have been returned to Licensor and that Licensee has discontinued its use of the Software.

10. ASSIGNMENT

Licensee shall not assign or otherwise transfer the Software or this Agreement to anyone, including any parent, subsidiaries, affiliated entities or third Parties, or as part of the sale of any portion of its business, or pursuant to any merger, consolidation or reorganization, without Licensor's prior written consent. Any assignment or transfer effected in violation of this Section 10 shall be void ab initio and of no force or effect.

11. FORCE MAJEURE

Neither party shall be in default or otherwise liable for any delay in or failure of its performance under this Agreement if such delay or failure arises by any reason beyond its reasonable control, including any act of God, any acts of the common enemy, the elements, earthquakes, floods, fires, epidemics, riots, failures or delay in transportation or communications; provided, however, that lack of funds shall not be deemed to be a reason beyond a party's reasonable control. The Parties will promptly inform and consult with each other as to any of the above causes that in their judgment may or could be the cause of a delay in the performance of this Agreement.

12. NOTICES

All notices under this Agreement are to be delivered by depositing the notice in the mail, using registered mail, return receipt requested, to the party's last known principal business address or to any other address as the party may designate by providing notice. The notice shall be deemed delivered four (4) days after the notice's deposit in the mail, if such notice has been sent by registered mail.

13. CHOICE OF LAW

This Agreement (including all Exhibits), including its formation, execution, interpretation, and performance, and the rights and obligations of the Parties hereunder, shall be governed by and construed in accordance with the laws of the Commonwealth of Pennsylvania, without regard to any conflicts of law (or choice of law) principles thereof.

14. CONSENT TO JURISDICTION

In the event that either party initiates litigation relating to or arising out of this Agreement, Licensor and Licensee irrevocably submit to the exclusive jurisdiction of the state or federal court in or for Philadelphia, Pennsylvania for the purposes of any suit, action or other proceeding relating to arising out of this Agreement or any transaction contemplated hereby or thereby (“Legal Proceedings”). Licensee further agree that service of any process, summons, notice, or document by U.S. registered mail to such Party’s respective address shall be effective service of process for any Legal Proceeding. Licensor and Licensee irrevocably and unconditionally waive any objection to personal jurisdiction and/or the laying of venue of any Legal Proceeding in the state or federal court in or for Philadelphia, Pennsylvania, and hereby further irrevocably and unconditionally agree not to plead, argue, or claim in any such court that any Legal Proceeding brought in any such court has been brought in an inconvenient forum and otherwise waive any and all objections to the forum.

15. EXPORT CONTROLS

Licensee shall not export or reexport, directly or indirectly, the Software without complying with the export controls imposed by the United States Export Administration Act of 1979, as amended (or any future U.S. export control legislation) and the regulations promulgated thereunder.

16. GOVERNMENT END USERS

If Licensee is acquiring the Software for or on behalf of a subdivision of the U.S. federal government, this Section 16 shall apply. The Software was developed completely at private expense, is existing computer software, is a trade secret for all purposes of the Freedom of Information Act, is “restricted computer software” and in all respects proprietary data belonging solely to Licensor, and all rights are reserved under the copyright laws of the United States. Use, duplication, or disclosure by the Government is subject to restricted rights as set forth in subparagraphs (a) through

(d) of the Commercial Computer Software Restricted Rights clause at FAR 52.227-19, or for DoD units, the restrictions as set forth in subparagraph (c)(1)(ii) of the Rights in Technical Data and Computer Software clause at DFARS 252.227-7013.

17. TRADEMARKS

Licensee agrees that SKF @ptitude Analyst, SKF @ptitude Inspector, SKF @ptitude Observer, SKF @ptitude Decision Support or any other software within the SKF @ptitude family suite and the trade dress, logos and other designations of source used by Licensor to identify the Software are trademarks or registered trademarks of Licensor. Licensee shall not use Licensor’s trademarks or service marks without the prior written consent of Licensor. If the Software contains any active links to web sites, you agree to maintain such active links and not redirect or modify them.

18. GENERAL PROVISIONS

(a) **Complete Agreement.** The Parties agree that this Agreement is the complete and exclusive statement of the agreement between the Parties, which supersedes and merges all prior proposals, understandings and all other agreements, oral or written, between the Parties relating to the use of the Software.

(b) **Amendment.** This Agreement may not be modified, altered or amended except by written instrument duly executed by both Parties. Any purchase orders or other ordering documents issued to Licensee by Licensor shall not have the effect of amending or modifying this Agreement, and shall only serve to memorialize the number of licenses or products ordered by Licensee. In the event of a conflict between the PSP Policies and this Agreement, the terms of this Agreement shall control.

(c) **Waiver.** The waiver or failure of either party to exercise in any

respect any right provided for in this Agreement shall not be deemed a waiver of any further right under this Agreement.

- (d) **Severability.** If any provision of this Agreement is invalid, illegal or unenforceable under any applicable statute or rule of law, it is to that extent to be deemed omitted. The remainder of the Agreement shall be valid and enforceable to the maximum extent possible.
- (e) **Read and Understood.** Each party acknowledges that it has read and understands this Agreement and agrees to be bound by its terms.
- (f) **Limitations Period.** No action arising under, or related to, this Agreement, may be brought by either party against the other more than two (2) years after the cause of action accrues, unless the cause of action involves death or personal injury.
- (g) **Attorneys' Fees.** In the event any litigation is brought by either party in connection with this Agreement, the prevailing party in such litigation will be entitled to recover from the other party all the costs, reasonable attorneys' fees, and other expenses incurred by such prevailing party in the litigation.

(h) **Authorized Representative.** The person installing or using the Software on behalf of Licensee represents and warrants that he or she is legally authorized to bind Licensee and commit Licensee to the terms of this Agreement.

(i) **Injunctive Relief.** Licensee agrees that Licensor may suffer irreparable harm as a result of a violation of Sections 2, 4, 6, 10, 15, and 17 of this Agreement and that monetary damages in such event would be substantial and inadequate to compensate Licensor. Consequently, Licensor shall be entitled to seek and obtain, in addition to such other monetary relief as may be recoverable at law or in equity, such injunctive other equitable relief as may be necessary to restrain any threatened, continuing, or further breach by Licensee without showing or proving actual damages sustained by Licensor and without posting a bond.

CM-F0176 (Revision F, January 2011)

Index

@

@ptitude Monitoring Suite 1-1

3

3D 5-30

A

adding pictures 6-33
advanced vibration-analysing tool 5-50
alarm 2-4, 5-39, 5-50, 6-49
alarm group 2-5, 6-49
alarm, automatic 4-66
amplitude filtering 5-48
analogue channel 4-29
analysis features 2-2
annotations 5-14
associated measurements 4-56
auto alarm 6-76
auto save graph settings, everyone or just me 6-12
automatic alarm 4-66

B

background 6-12, 6-14, 6-33
balancing 6-79
band cursor 5-18
band marker 5-65
baseline values, diagnosis 5-52
bearing defect frequencies 5-20
BOV 4-30, 5-39
buffer 5-52, 5-71

C

centerline 4-48, 4-54, 4-87, 5-56
channel 4-7, 5-10
class 1 gating, class 2 gating 4-49, 4-57, 4-59, 4-76, 5-51, 6-69
clear 5-18
coded note 6-85
cold gap 5-56
combination plot 5-57
command window 4-28
conditional activation 4-38
configuration changes 6-32
configure users 6-26

connect function 4-26
connection history 4-25
connection log 4-25
copy 5-14
copy active window tool B-1
copy machine 4-94
correlation tolerance 5-14
create IMx/MasCon units and channels 4-7
cursor 5-14, 5-20
curve fitting 5-14
custom band 4-68

D

dashboard 6-21
data acquisition device (DAD) 1-2, 4-27
data miner 6-78, B-2
data tagging 4-49, 5-73
data tagging group 4-52, 6-45
database 4-3
database information 6-31
delete data 6-78
delete data automatically 6-69
device settings tab 6-77
device, create 4-8
diagnosis display 5-50
diagnosis rules 5-50, 6-35
diagnosis tab 4-35
diagram view 5-12
DiagX 5-15, 5-17
digital channel 4-32
DPE (Digital Peak Enveloping) 2-2

E

elevation 5-14, 5-30
event capture
 export to UFF 5-70
 manual capture 5-69
 measurement point 6-63
 plots 5-61
event capture behaviour A-1
event capture group 4-2, 6-53, 6-57
event case reports 5-76
event cases 5-76
event cases tool B-1
event log 6-82
export data 5-15, 5-81, 6-47
external channel 4-19
external database 6-3

F

fault frequencies 5-15, 5-17
FFT 2-2, 4-39, 4-54, 4-64, 5-20
filter on machine parameter 5-73
filtering 5-71
firmware 4-27
frequency unit 5-15

G

gear 4-88, 5-38
gear inspector 5-38
gearbox 4-88, 5-38
generate report 6-4
getting started 3-1
go to 5-15
GPS 4-10
graph settings 5-13
graphic displays 5-13

H

hardware connectivity 2-1
harmonic cursor 5-18
harmonic measurement point 4-86, 6-56, 6-79
harmonics 5-18, 5-20, 6-35
hierarchy view 4-1, 5-1
hierarchy view status icons 5-3
historical display 5-26
history 5-26, 5-30

I

IEC external communication 4-17
IEC status codes 5-82
import data 6-48
IMx/MasCon 4-7, 5-10, 6-32
IMx-Rail D-4
inverted 5-15

K

keep forever flag 5-16, 5-70

L

language change feature 3-2
legend 5-13, 5-15
libraries 6-41
license key 3-1, 6-86
line style 5-15
link to hierarchy tool B-2
listen to time waveform 5-15
log off

process overview 4-93
switch user type 3-2, 4-93
logical architecture 1-3
logon 3-1
change language 3-2
switch user type 3-2, 4-93

M

machine 5-1
machine copy wizard 4-94
machine parameters 4-39
machine parts 4-88
machine properties 4-33
machine template 6-46
machine, create 4-4
maintenance planner 5-80
manage databases interface 6-1
markers 5-15
max scale 5-15
measurement date 5-81
measurement group 6-50
measurement point 4-25, 4-47
add edit delete 4-46
measurement point, dynamic 4-47
measurement point, trend 4-48
Microlog Analyzer 2-1, 4-49, 4-51, 4-56, 6-84
min scale 5-15
Modbus 4-12
Modbus export 4-16
Modbus master communication 4-13
Modbus slave communication 4-15
mode 5-15
monitor service viewer 6-78
multi trend 5-42
multiple gating point (MGP) 4-49, 4-51, 4-57, 4-74, 5-42
multiple point update wizard 4-98

N

network connectivity requirements 1-6
node 4-4
noise reduction 5-15
notes 5-74
notes tool B-1

O

on-line 4-7
OPC 4-40, 5-10
OPC channel 4-40
OPC server 4-40
external 4-42
internal 4-41

- status tag 4-45
- operating and storage conditions 4-60
- orbit 5-36
- out-of-roundness 5-37, B-3

P

- palette steps 5-15
- phase 5-20
- picture 6-33
- play sound 5-23
- point 5-1
- point settings 4-98
- polar 5-55, B-4
- print active window tool B-1
- process overview 4-91
- profile 5-37, B-3
- Protean Diagnoses tab 4-37
- Protean Diagnosis C-1

R

- raw 5-23
- reference 5-16
- remote monitoring possibilities 1-5
- remove DC 5-16, 5-69
- restart 4-24
- roles 6-21
- rotation 5-30
- roundness 5-37, B-3
- run cycle group 6-53
- runout compensation 4-86, 5-16

S

- save to diagram box 5-16
- scale 5-16, 5-20
- scale type 5-16
- scaling 5-16
- scheduled dynamic data storage 4-63
- sectors 5-16
- security roles 6-21
- SEE 4-48
- sensor 4-7, 5-56
- set component 5-44
- set speed 5-16
- set time 4-24
- settling time 4-30
- shaft 4-88, 5-16, 5-38, 5-56
- shaft centerline 4-48, 4-54, 4-87, 5-56
- shaft cycle time 5-16
- show bottom pane tool B-2
- show phase 5-16
- show pulses 5-16
- show tree view tool B-2
- show values 5-16

- side band marker 5-18
- sidebands 5-18
- simultaneous data sampling 6-49
- simultaneous measurement group 6-53
- single cursor 5-17
- SKF Rail Track Monitoring D-1
- sound card 5-23
- spectra 5-20
- spike filter 4-62
- start/stop markers 5-16
- status, hierarchy view 5-3
- status, OPC server 4-45
- sub machine, create 4-6
- switch user type at logon 3-2
- synchronize 4-24
- system configuration 4-1
- system log 6-32
- system view 5-10

T

- tag 4-40
- teeth 5-38
- time signal 5-20
- time signal display 5-26
- time synchronization thresholds 6-77
- time waveform 5-20, 5-23
- toolbars B-1
- topology 5-33
- transducer angle 4-30, 4-33, 5-56
- transient group 6-53, 6-56
- trend 5-39

U

- unit 5-16
- user preferences 6-9
- user preferences, process overview settings 6-14
- user rights 6-21, 6-26
- users 6-26

V

- visible trend 5-45

W

- warning 5-39, 5-50, 6-49
- waterfall 5-30
- wheel 5-37, B-3
- wizard
 - machine copy 4-94
 - multiple point update 4-98
 - report 2-5
- workspace manager 6-7

workspace view 5-11

X

x-axis 5-17

Y

y-axis 5-17

Z

z-axis 5-17

zero padding 5-17

zoom 5-18, 5-30, 5-39